

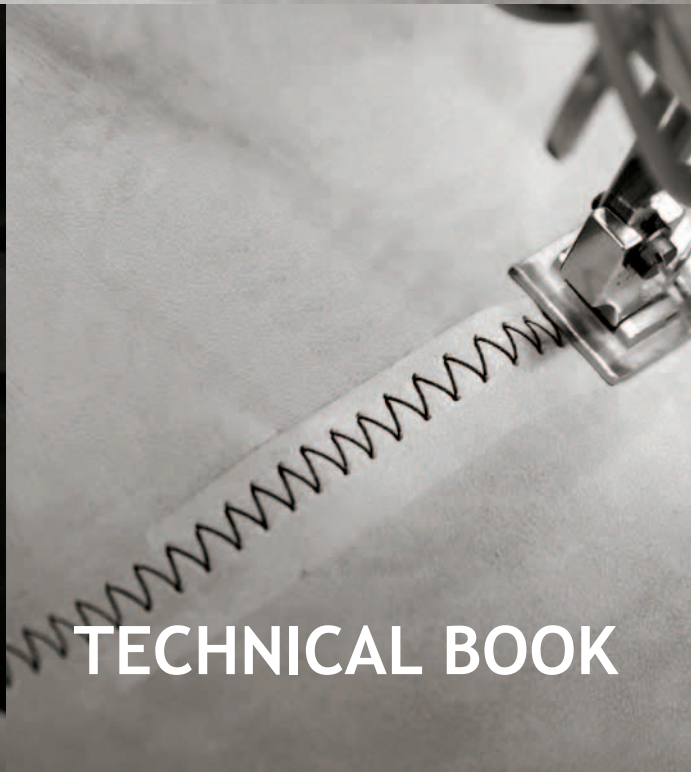

LUDOVICA  
MASCHERONI  
HOME ATELIER



TECHNICAL BOOK

LUDOVICA  
MASCHERONI  
HOME ATELIER



# “Ancora oggi, dopo tanti anni.”

“Even today, after all these years.”

Ancora oggi, dopo tanti anni, nella nostra azienda seguiamo gli insegnamenti che sono il frutto dell'esperienza di ogni giorno, l'essenza di una cultura del lavoro che si impara “con il fare quotidiano”, usando le mani e il cuore, una conoscenza che deve saper rispondere a regole ben precise in termini di qualità e perfezione.

Dopo anni di collaborazioni con le più importanti aziende del mobile, della moda e del design, abbiamo sviluppato la nostra esperienza nell'haute couture, unendo così il nostro know how alle tecniche di lavorazioni tradizionali del mobile. Nelle nostre creazioni usiamo moltissimo gli strumenti più antichi al mondo, le mani; mani che si muovono incessantemente e compiono gesti ritmati, che cuciono con precisione estrema, che incessantemente rivoltano il cuoio o la pelle, ma che portano ad una perfezione che sfiora l'arte.

Mani che prendono ordini da un cuore che vive della passione per il proprio lavoro, volto alla ricerca del bello in assoluto, oggi come ieri. Un insieme di persone unite da un interesse comune, il saper fare, ognuno nel proprio ruolo, per il bene di tutti; uomini e donne che credono nell'azienda e sanno che la propria opera è un tassello indispensabile alla crescita comune e la qualità che offriamo è il frutto della loro qualità interiore.

Proprio come Fabio Mascheroni afferma: “La qualità nasce dai gesti di ognuno di noi” e da quell'atmosfera di serenità che solo un team forte e coeso può trasmettere.

*Even today, after decades of experience, our company is still following and enhancing the expertise and skills we have gained day in and day out. This is the essence of a work culture based on learning from “everyday experience”, using our hands and our hearts, building a knowhow that meets specific rules regarding quality and perfection. After years of work with the world's most important furniture, fashion, and design companies, we have developed our own experience in haute couture, combining our knowhow with traditional furniture workmanship and crafting.*

*Our creations arise from the use of bygone tools – our hands – constantly moving in rhythmic movements, stitching with the utmost precision, flipping the leather and the thick leather over and over again, leading to a level of perfection that comes close to art.*

*These are hands ruled by a heart that lives within a true passion for their work, pursuing absolute beauty, be it yesterday or today. This is also a group of people brought together by a common love – artisan expertise – each with their own role, with the common good as a goal: men and women who believe in this Company and know that their work is a fundamental part of its growth, all aware that the quality we offer is the fruit of their caliber.*

*Just as Fabio Mascheroni highlights, “Quality is based on our each and every action”, and this aura can be expressed only when you have a strong, tight-knit team of great people.*

## INDEX

### Boiserie

Pag.10\_Giglio  
Pag.12\_Serena  
Pag.14\_Intrigo 15  
Pag.18\_Intrigo 30  
Pag.20\_Maldive  
Pag.22\_Edra  
Pag.24\_Veridiana  
Pag.26\_Cheope  
Pag.28\_Oxford  
Pag.30\_Armony  
Pag.32\_Intreccio 45°  
Pag.34\_Intreccio 90°  
Pag.36\_Atlas  
Pag.38\_Café Royal  
Pag.40\_Prometeo  
Pag.42\_Esmeralda  
Pag.44\_Mondrian

### Sofas/Armchairs

Pag.48\_Ermelin  
Pag.52\_Privé  
Pag.56\_Trevis  
Pag.62\_Clero  
Pag.68\_Eloro  
Pag.72\_Oxford  
Pag.76\_Armony  
Pag.82\_Prometeo  
Pag.86\_Lord  
Pag.92\_Clessidra  
Pag.94\_Titano  
Pag.100\_Aura  
Pag.102\_Prissy II  
Pag.104\_Prissy  
Pag.106\_Sophia  
Pag.108\_Oxford  
Pag.110\_Oxford Club

### Pouf

#### Little Benches

Pag.114\_Cubo  
Pag.116\_Torquato  
Pag.118\_Venere  
Pag.120\_Intrigo  
Pag.122\_Quadro  
Pag.124\_Oxford  
Pag.126\_Eclisse

#### Coffee Tables

Pag.130\_Twin-Bridge  
Pag.132\_Eliot  
Pag.134\_Eloro  
Pag.136\_Armony  
Pag.138\_Oxford  
Pag.140\_Edra

#### Tables

Pag.144\_Basilio  
Pag.146\_Argo  
Pag.148\_Doralice  
Pag.150\_Tolomeo  
Pag.152\_Odeon  
Pag.154\_Globo  
Pag.156\_Oxford  
Pag.158\_Chelsea  
Pag.160\_Loto  
Pag.162\_Phoenix  
Pag.164\_Balmoral

### Chairs

#### Armchairs

Pag.168\_Basilia  
Pag.172\_Fantasma  
Pag.180\_Doralice  
Pag.182\_Artemide  
Pag.184\_Odeon  
Pag.186\_Luna  
Pag.188\_Loto  
Pag.190\_Oxford  
Pag.196\_Chelsea  
Pag.198\_Phoenix  
Pag.200\_Balmoral

#### Sideboards

Pag.204\_Doralice  
Pag.206\_Odeon  
Pag.208\_Loto  
Pag.210\_Oxford  
Pag.214\_Dorian  
Pag.216\_Phoenix  
Pag.218\_Balmoral

#### Console

Pag.222\_Basilia  
Pag.224\_Altai  
Pag.226\_Doralice  
Pag.228\_Oxford  
Pag.230\_Loto  
Pag.232\_Stilo  
Pag.234\_Dorian  
Pag.236\_Intrigo  
Pag.238\_Eden

### Showcases

#### Bookcases

Pag.242/256\_Oxford  
Pag.246\_Dorian  
Pag.250\_Serena  
Pag.254\_Diletta

#### Bed

Pag.260\_Prissy  
Pag.262\_Altai  
Pag.264\_Intrigo  
Pag.266\_Eloro  
Pag.268\_Edra  
Pag.270\_Eden  
Pag.272\_Grace  
Pag.274\_Oxford  
Pag.276\_Skyline  
Pag.278\_Oxford Club

#### Chests of Drawers

#### Bedside Tables 6-Drawers unit

Pag.284/288\_Erasmo  
Pag.286\_Erasmo 150  
Pag.290\_Prissy  
Pag.296\_Eloro  
Pag.302\_Dorian  
Pag.308\_Eden  
Pag.316\_Intrigo  
Pag.322\_Edra  
Pag.326\_Skyline  
Pag.328\_Oxford  
Pag.334\_Altai

### Toilettes

#### Writing Desks

#### Dressing Tables

Pag.338\_Manhattan  
Pag.340\_Jackie  
Pag.342\_Torquato  
Pag.344\_Venere  
Pag.346\_Xeno  
Pag.348\_Stilo  
Pag.350\_Chelsea  
Pag.352\_Oxford

#### Walk-in Closets

Pag.356\_Alice  
Pag.358\_Ariel  
Pag.360\_Arluna  
Pag.362\_Oxford Club

#### Mirrors

Pag.370\_Grace  
Pag.372\_Intrigo  
Pag.374\_Ninfea  
Pag.376\_Alias  
Pag.378\_Oxford  
Pag.380\_Dorian  
Pag.382\_Eden  
Pag.384\_Chelsea  
Pag.386\_Skyline

#### Lamps

Pag.390\_Amery  
Pag.392\_Tricot  
Pag.402\_Oxford

### Accessories

Pag.410\_Sebastian  
Pag.410\_Oxford  
Pag.410\_Chelsea  
Pag.411\_Frame  
Pag.411\_Chic  
Pag.412\_Compass  
Pag.418\_Legn  
Pag.420\_Sass  
Pag.422\_Passepartout

#### Mattresses and bed base

Pag.426\_Mattresses  
Pag.430\_Bed base

#### Synoptic index

Pag.432

#### Materials

Pag.454\_Marbles  
Pag.456\_Essences  
Pag.458\_Metals  
Pag.459\_Mirrors  
Pag.459\_Glass  
Pag.460\_Linens  
Pag.462\_Wools  
Pag.464\_Cottons  
Pag.466\_Velvets  
Pag.468\_Nubuck  
Pag.470\_Leathers

**Boiserie 08**

**Sofas / Armchairs 46**

**Poufs / Little Benches 112**

**Coffee Tables 128**

**Tables 142**

**Chairs / Armchairs 166**

**Sideboards 202**

**Consoles 220**

**Showcases / Bookcases 240**

**Beds 259**

**Chests of Drawers / Bedside Tables / 6-Drawers unit 282**

**Toilettes / Writing Desks / Dressing Tables 336**

**Walk-in Closets 354**

**Mirrors 368**

**Lamps 388**

**Accessories / Occasional Furniture 408**

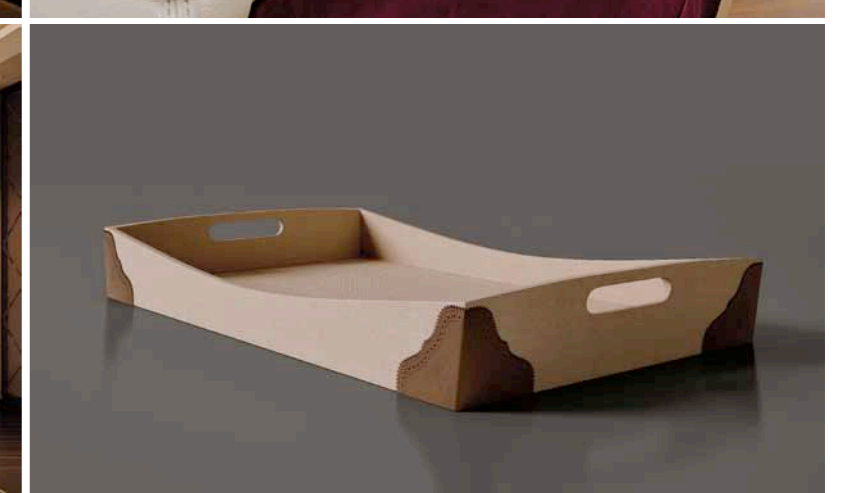
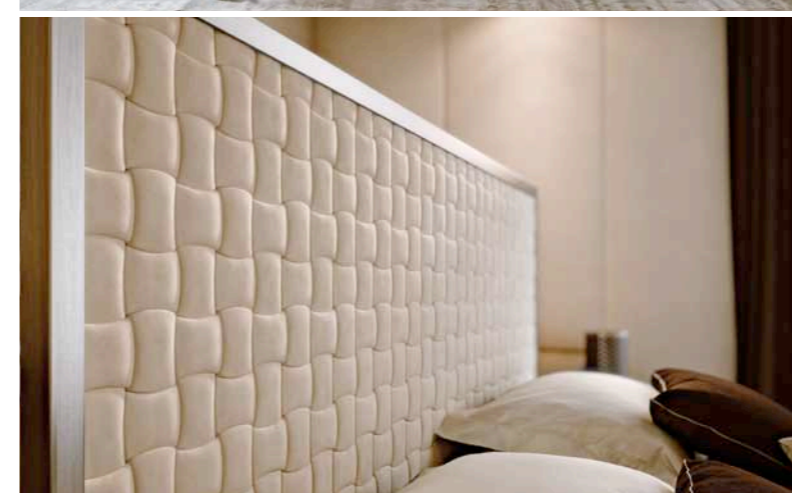

## Boiserie

Sofas / Armchairs

Poufs / Little Benches

Coffee Tables

Tables

Chairs / Armchairs

Sideboards

Consoles

Showcases / Bookcases

Beds

Chests of Drawers / Bedside Tables / 6-Drawers unit

Toilettes / Writing Desks / Dressing Tables

Walk-in Closets

Mirrors

Lamps

Accessories / Occasional Furniture

# Giglio



Boiserie con struttura in legno rivestita in pelle, pannelli in 100% Cashmere.

Dettaglio: giglio in basso rilievo rivestito in pelle.

*Wainscoting with wooden frame covered in leather. Panels in 100% Cashmere.*

*Detail: lily in bas-relief covered in leather.*

Art.101\_GIGLIO

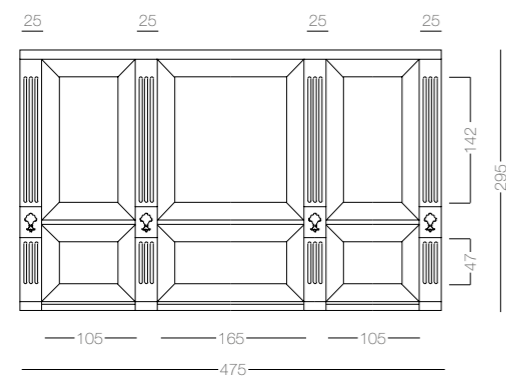

# Serena



Boiserie con struttura in legno rivestita in Lino con leggera imbottitura.

*Wainscoting with wooden frame covered in Linen with light padding.*

**Art.102\_SERENA**

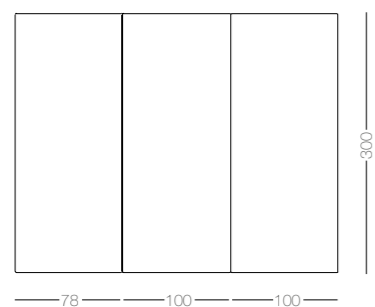



# Intrigo 15

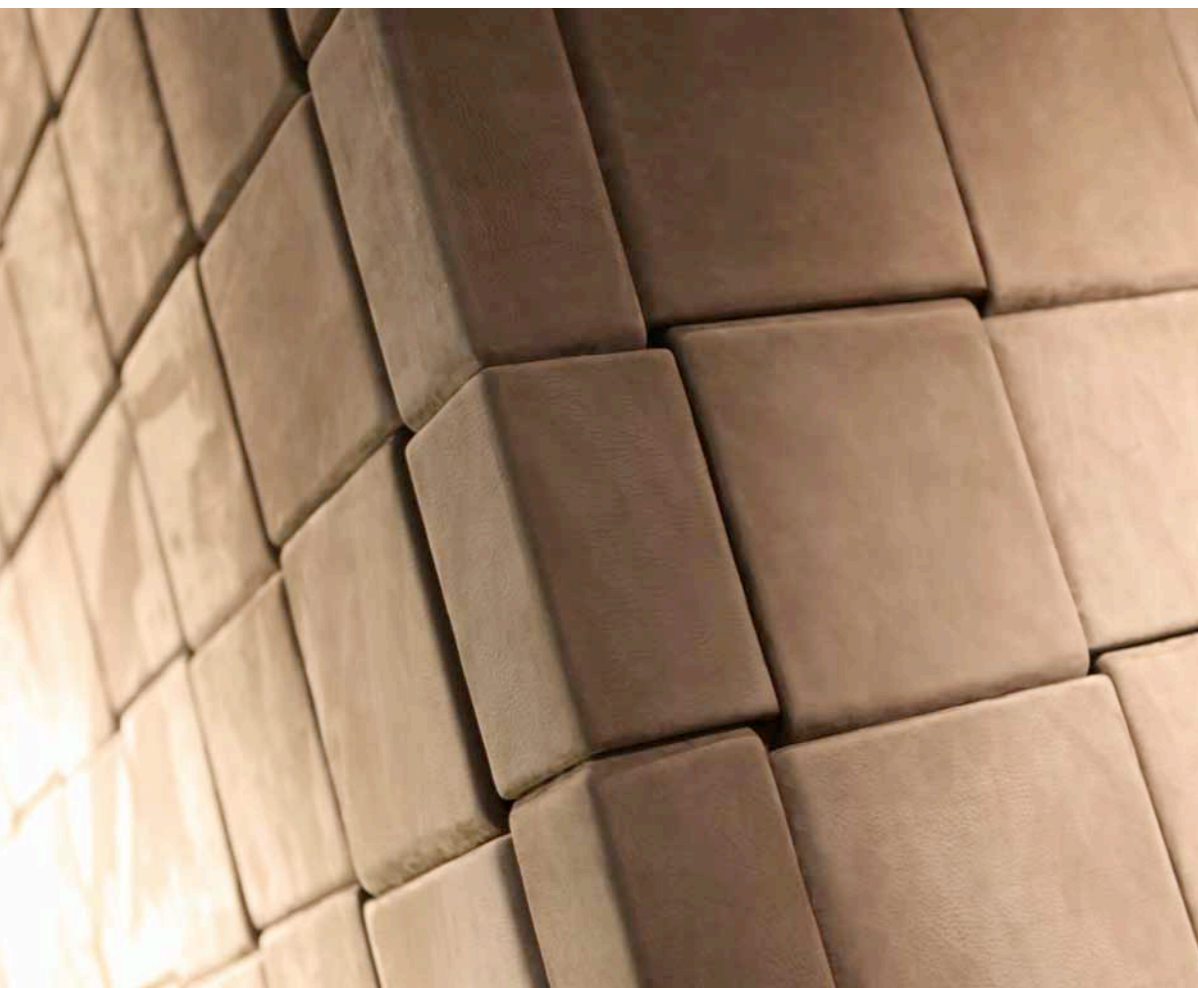

Boiserie con telaio in legno, rivestita con formelle in legno, metallo o pelle.

*Wainscoting with wooden frame covered in wooden, metal or leather panels.*

Art.103\_INTRIGO 15

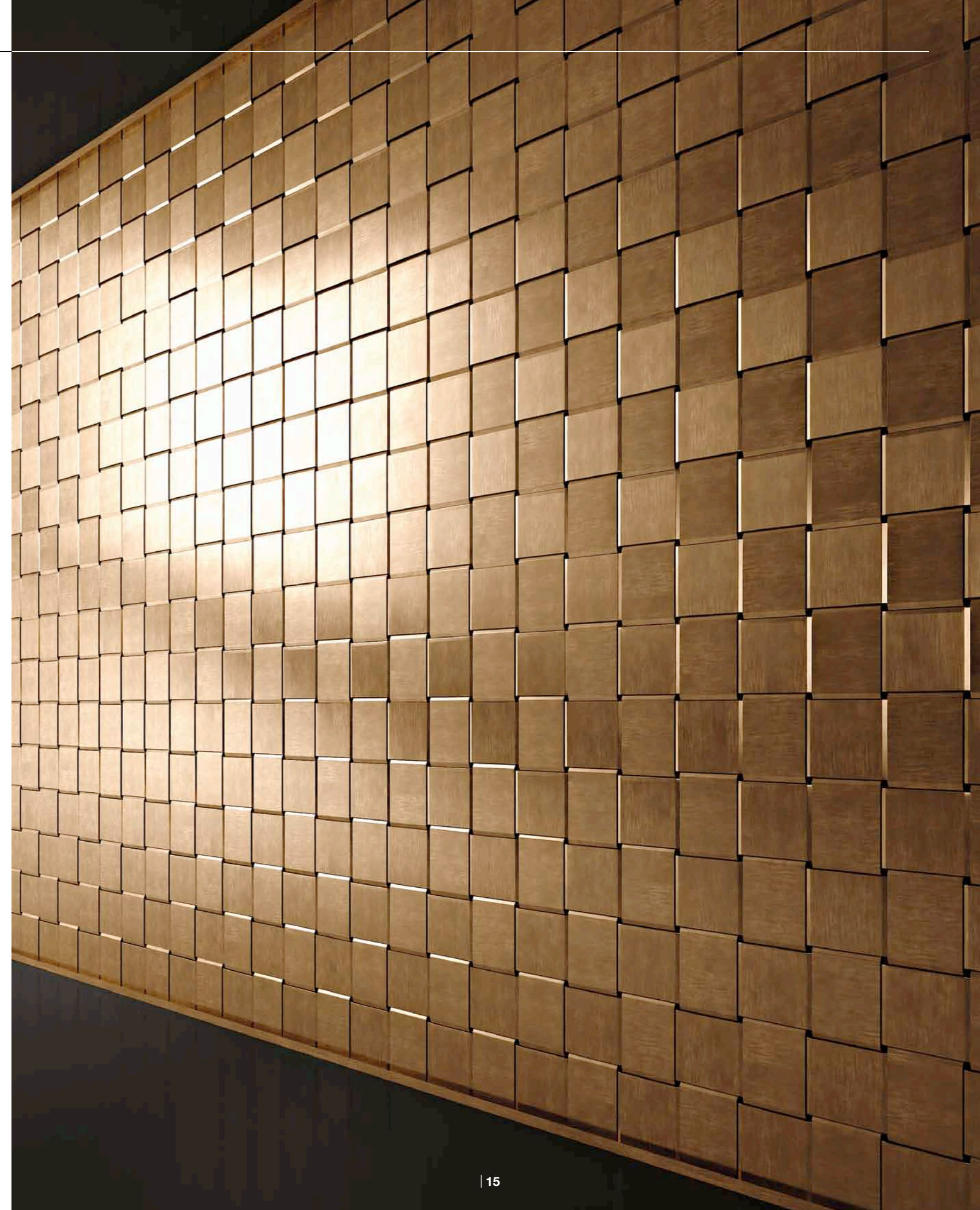
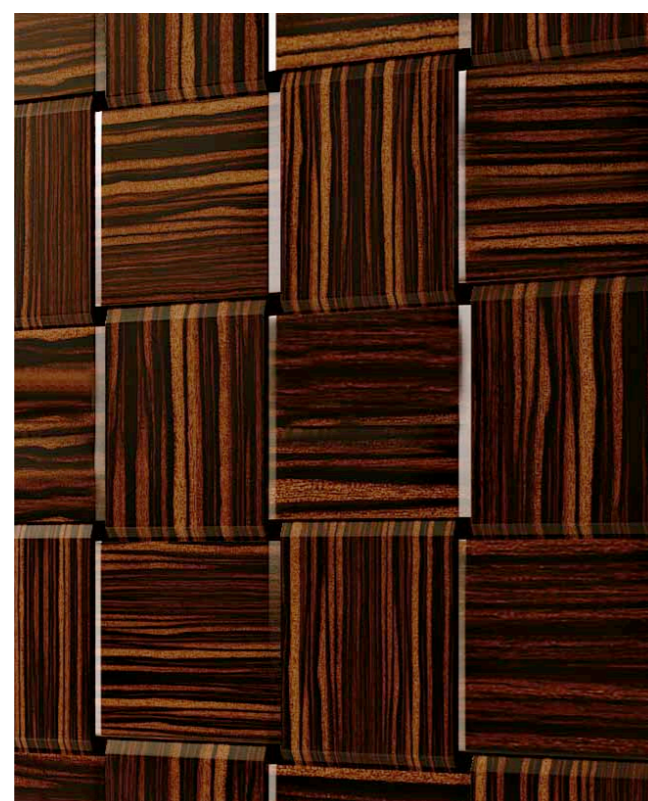
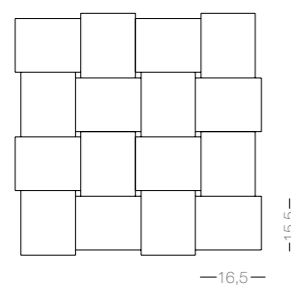

# Intrigo 15

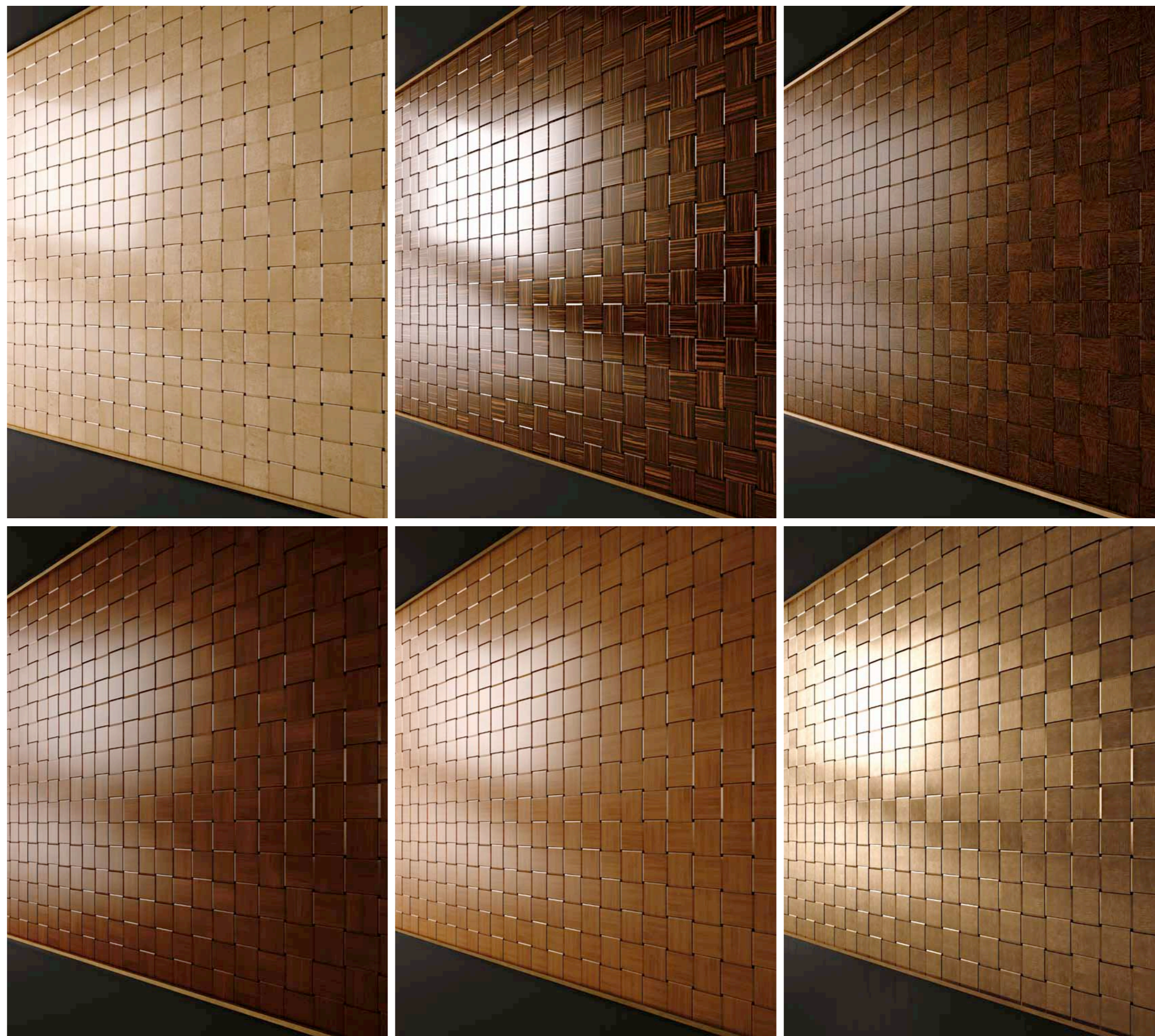

# Intrigo 30

Boiserie con telaio in legno rivestita con formelle in legno metallo o pelle.

*Wainscoting with wooden frame covered in wooden, metal or leather panels.*

**Art.103\_INTRIGO 30**

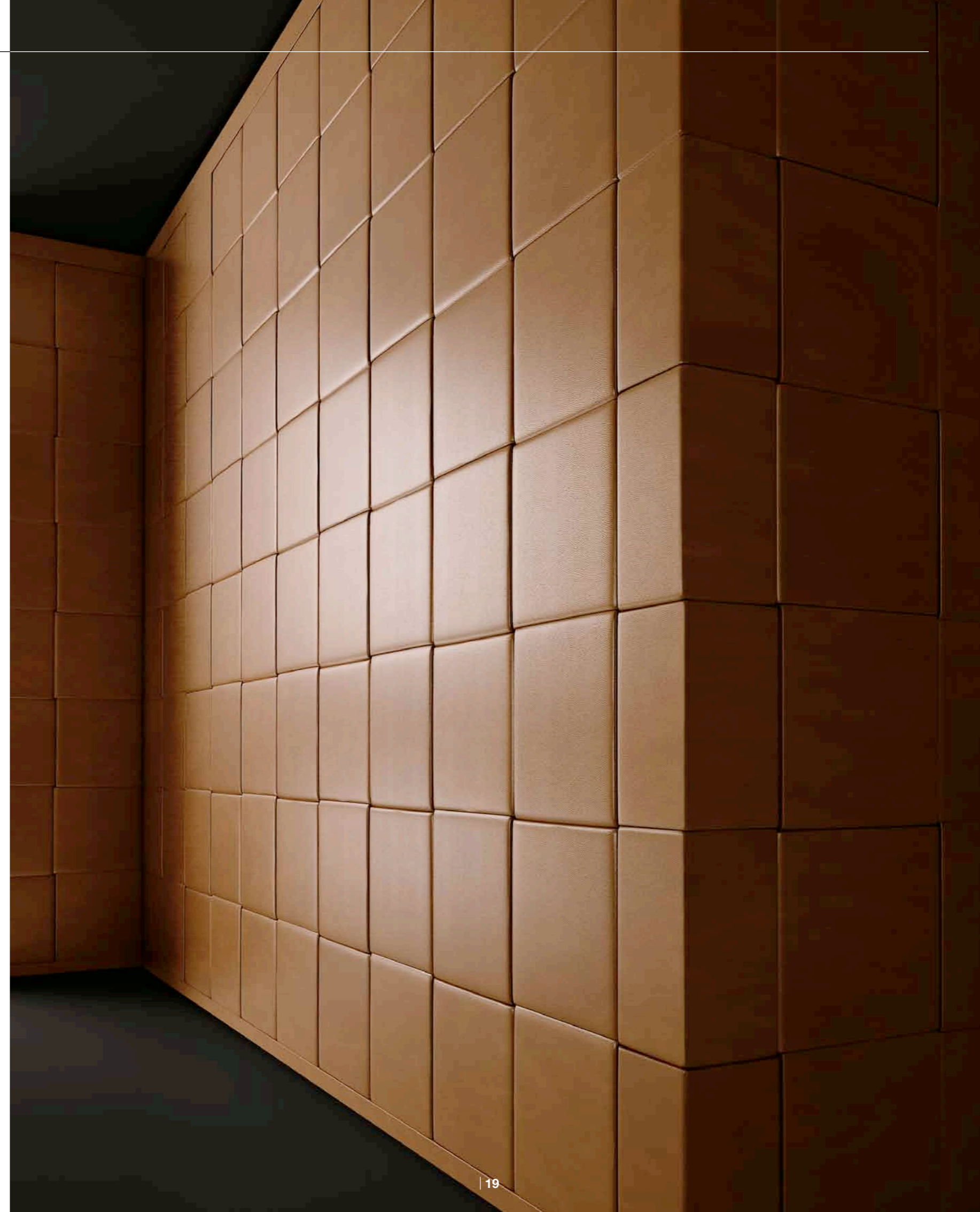
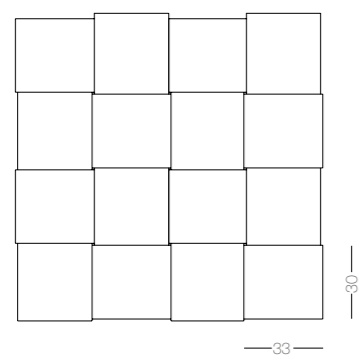

# Maldive



Boiserie con struttura in legno rivestita in Galuchat con motivi a rombo, cornice e fondo rivestiti in pelle Nubuck chiara selezionata Fiore Naturale.

*Wainscoting with wooden frame covered in Galuchat, with diamond-shaped patterns, frame and back panel covered in selected full grain light Nubuck leather.*

Art.104\_MALDIVE

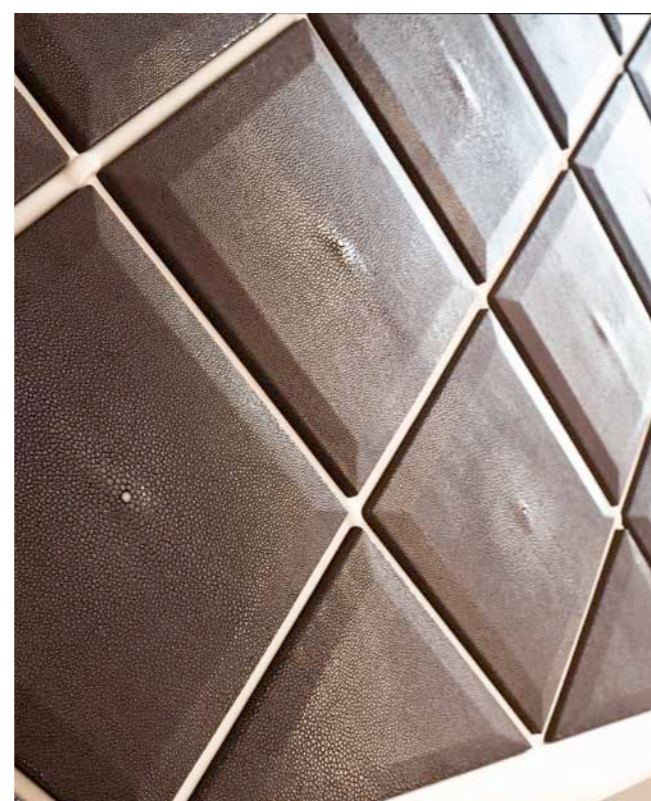
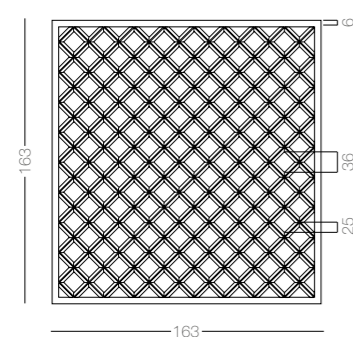

# Edra



Boiserie con struttura in legno rivestita in pelle e tessuto, leggera imbottitura per effetto soft touch.

*Wainscoting with wooden frame covered in leather and fabric, light padding with soft touch effect.*

Art.105\_EDRA

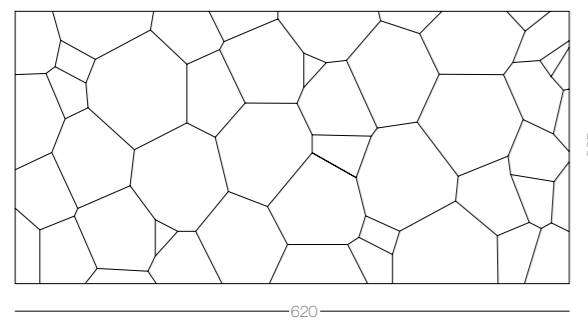

# Veridiana



Boiserie con struttura in legno rivestita in tessuto con leggera imbottitura centrale. Sagome in rilievo.

*Wainscoting with wooden frame covered in fabric with light central padding. Mouldings in relief.*

Art.106\_VERIDIANA

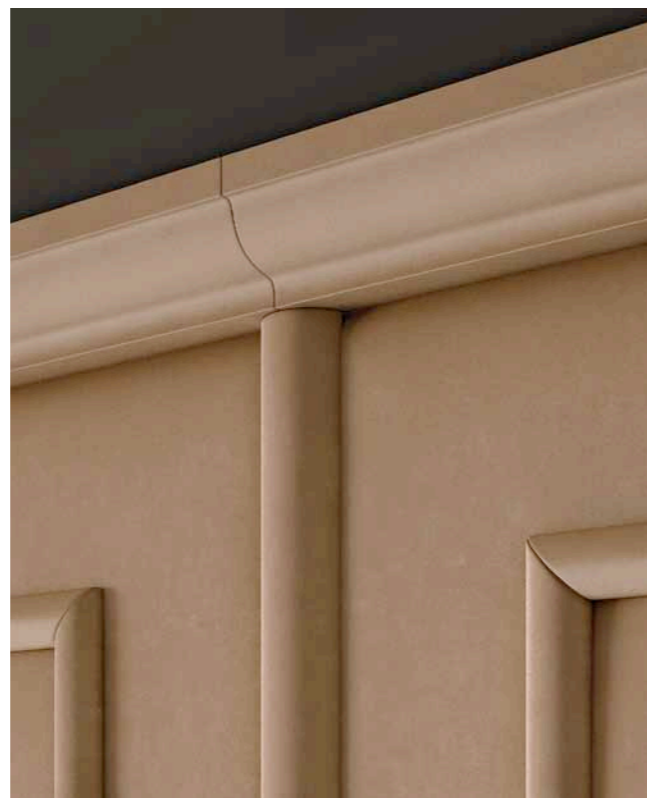
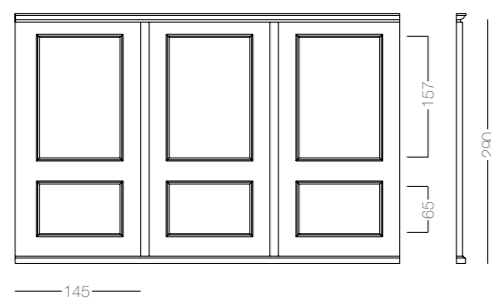

# Cheope

Boiserie con struttura in legno rivestita in pelle, parte superiore a doghe verticali, illuminazione a Led sotto mensola e parte inferiore semicilindrica.

*Wainscoting with wooden frame covered in leather, upper part with vertical slats, LED lighting under the shelf and lower part in semi-cylindrical shape.*

## Art.107\_CHEOPE

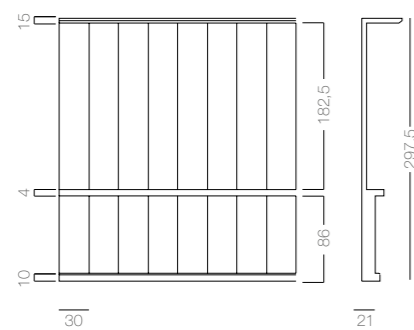

# Oxford

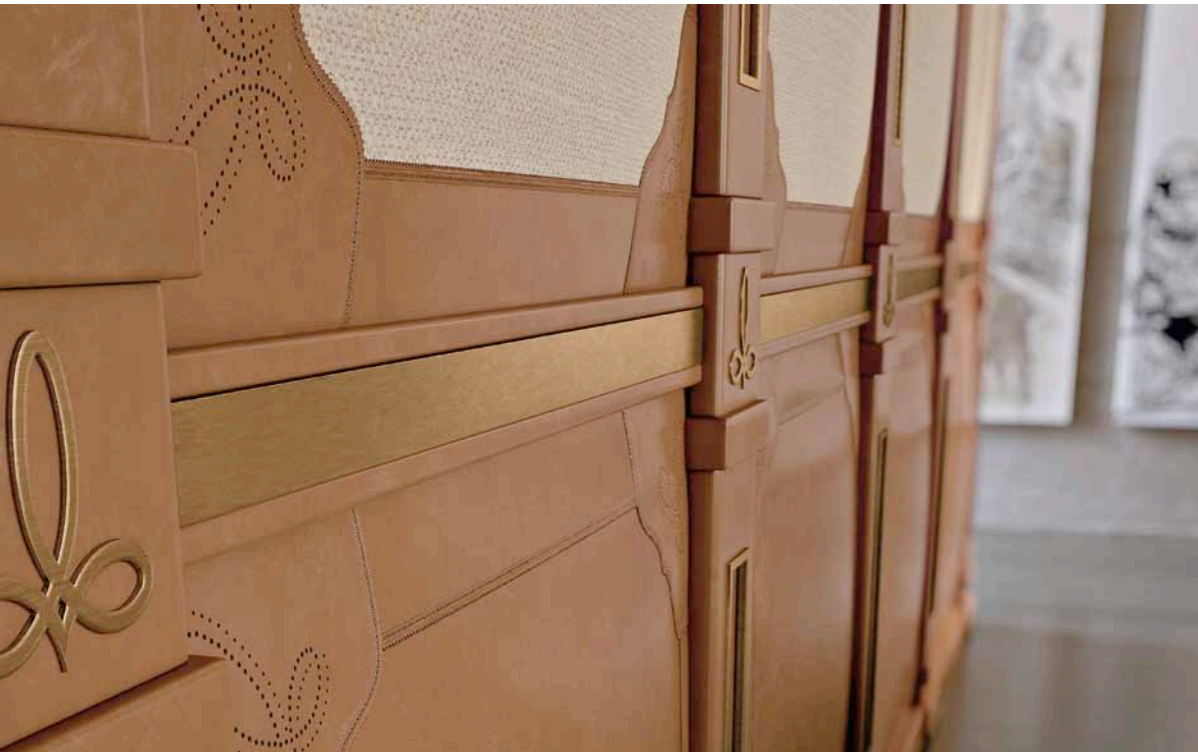

Boiserie con struttura in legno rivestita in pelle, pannelli in tessuto, inserti in ottone bronzato e dettagli in pelle traforata con decoro brogue.

*Wainscoting with wooden frame covered in leather, fabric panels, bronze-plated brass inserts and details in perforated leather with brogue decoration.*

Art.109\_ OXFORD

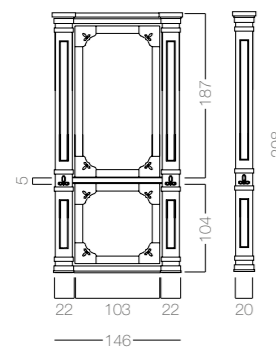



# Armony



Boiserie con struttura in legno, parte inferiore rivestita in velluto con sagome in rilievo e parte superiore rivestita in Lino leggermente imbottito.

*Wainscoting with wooden frame, lower part covered in velvet with mouldings in relief and upper part covered in lightly-padded Linen.*



**Art.110\_ARMONY**

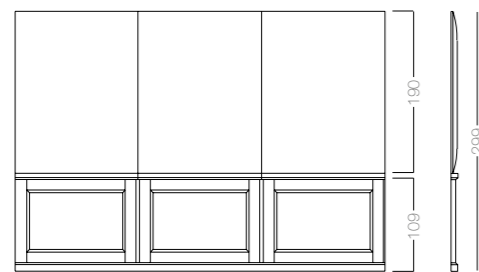

—131—

# Intreccio 45°



Boiserie con struttura in legno, colonne rivestite in pelle, parte inferiore composta da pannelli in pelle intrecciata a mano, parte superiore rivestita in tessuto leggermente imbottito. Dettagli in ottone bronzato.

*Wainscoting with wooden frame, columns covered in leather, lower part composed of panels in hand-interwoven leather, lightly-padded upper part covered in fabric. Details in bronze-plated brass.*

Art.111\_INTRECCIO 45°

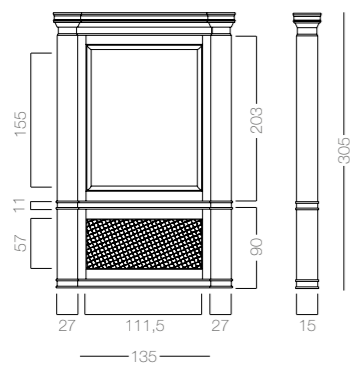

# Intreccio 90°



Boiserie con struttura in legno, colonne rivestite in pelle, parte inferiore composta da pannelli in pelle intrecciata a mano, parte superiore rivestita in tessuto leggermente imbottito. Dettagli in ottone bronzato.

*Wainscoting with wooden frame, columns covered in leather, lower part composed of panels in hand-interwoven leather, lightly-padded upper part covered in fabric. Details in bronze-plated brass.*



Art.111\_INTRECCIO 90°

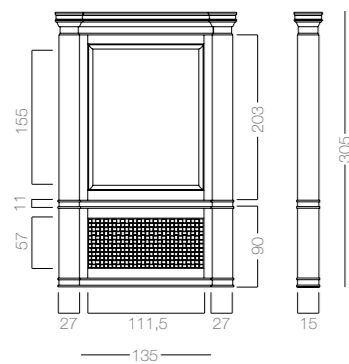

# Atlas

Rivestimento per pilastri con struttura in legno rivestita in pelle leggermente imbottita.

*Pillar cladding with wooden frame covered in lightly-padded leather.*

**Art. 112\_ATLAS**

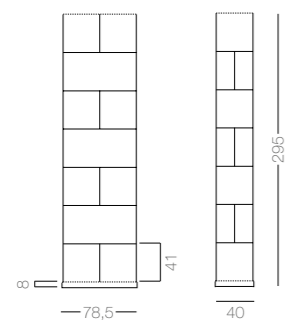

# Café Royal



Boiserie con struttura in legno rivestita con formelle in pelle imbottite.

*Wainscoting with wooden frame covered with panels in padded leather.*

Art.113\_CAFÉ ROYAL

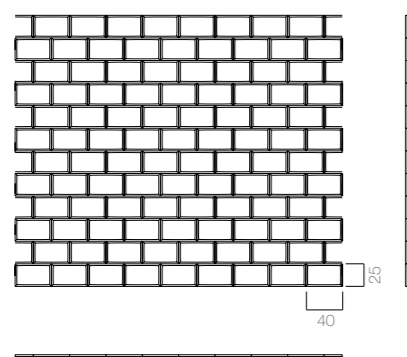

# Prometeo



Boiserie con struttura in legno rivestita in pelle e tessuto. Leggera imbottitura per effetto "soft touch". Cuciture tono su tono ai rivestimenti utilizzati e dettagli in ottone bronzato.

*Wainscoting with central frame covered in leather and fabric. Light padding to offer a "soft touch" effect. Tone-on-tone stitching for the covering used, and details in bronze-plated brass.*

Art.114\_PROMETEO

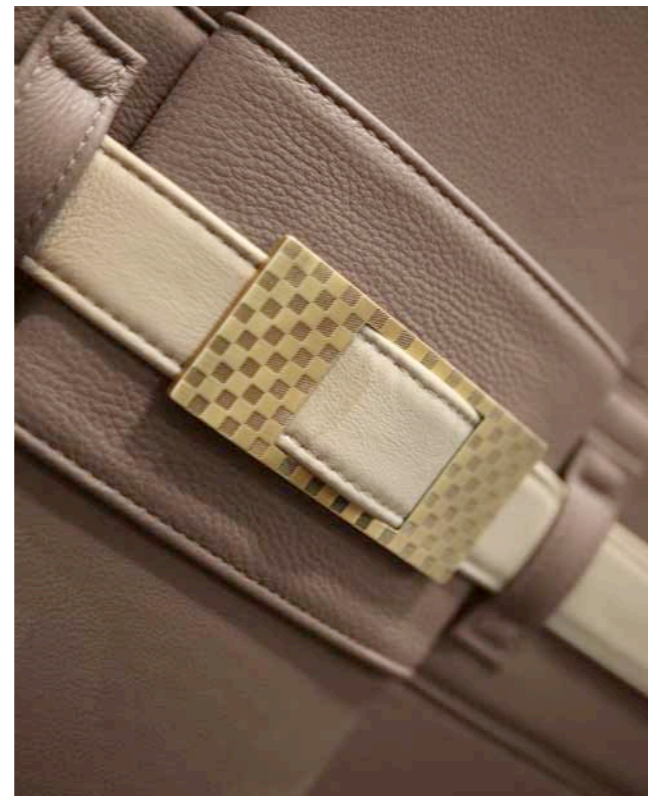
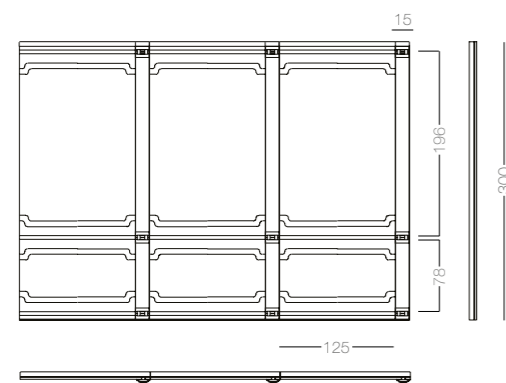

# Esmeralda

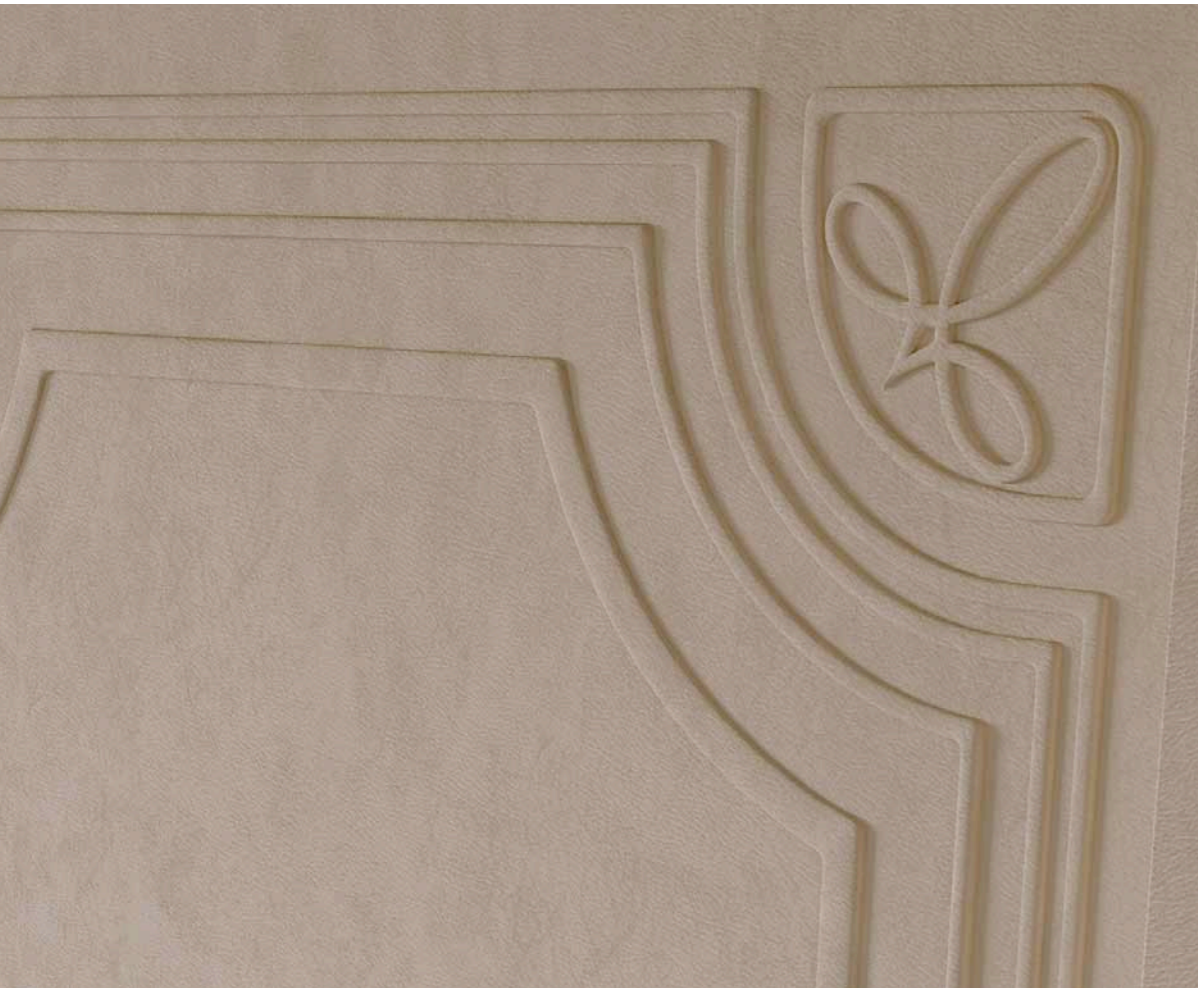

Boiserie con struttura in MDF  
pantografata rivestita in Nubuck.

*Wainscoting with pantographed  
MDF, covered in Nubuck.*

Art.115\_ESMERALDA

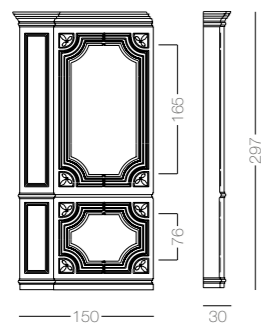

# Mondrian



Boiserie con struttura in legno rivestita in pelle leggermente imbottita.

*Wainscoting with wooden frame covered in lightly-padded leather.*

**Art.116\_MONDRIAN**

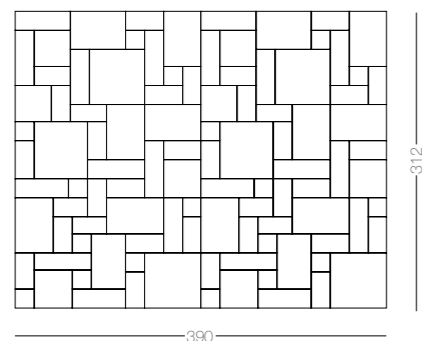



Boiserie

**Sofas / Armchairs**

Poufs / Little Benches

Coffee Tables

Tables

Chairs / Armchairs

Sideboards

Consoles

Showcases / Bookcases

Beds

Chests of Drawers / Bedside Tables / 6-Drawers units

Toilettes / Writing Desks / Dressing Tables

Walk-in Closets

Mirrors

Lamps

Accessories / Occasional Furniture

# Ermelin



Divano con fusto in legno di Faggio, sistema di molleggio tradizionale con molle, cinghie elastiche intrecciate, fibre vegetali e crine di cavallo, imbottitura in piuma d'oca e poliuretano espanso, rivestimento in tessuto e pelle. Basamento in ottone bronzato.

*Sofa with frame in beech, traditional suspension system on springs, interwoven elastic straps, vegetable fibres and horsehair, padding in goose feather and expanded polyurethane, covering in leather and fabric. Base in bronze-plated brass.*



Art.201\_ERMELIN

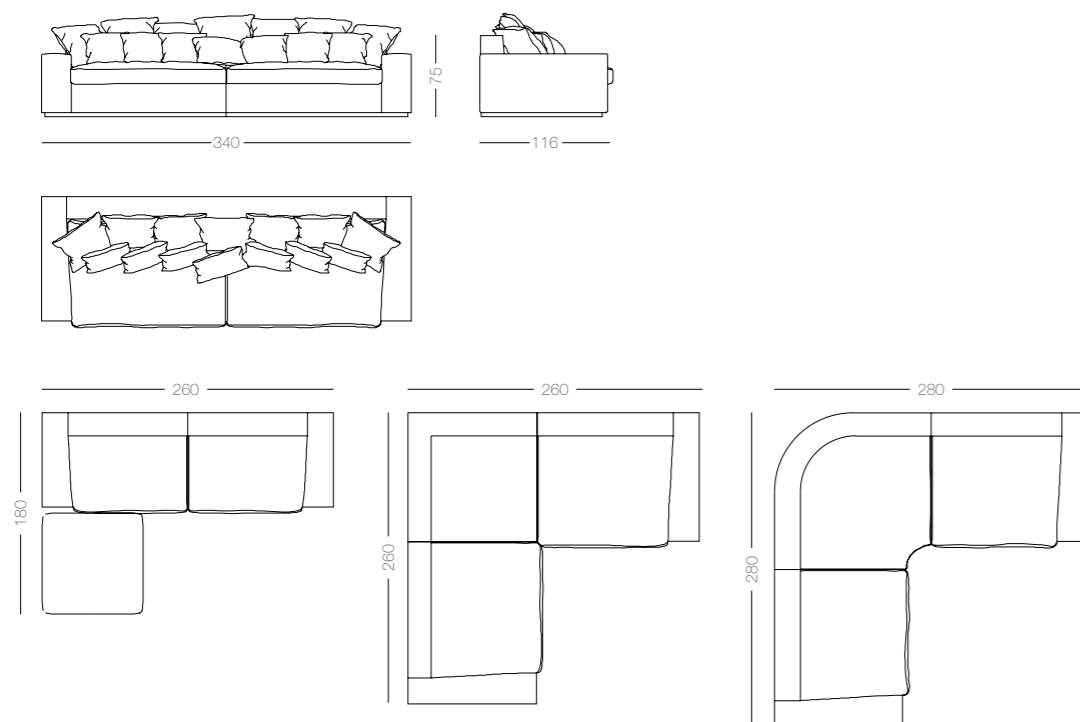

# Ermelin

Poltrona con fusto in legno di Faggio, sistema di molleggio tradizionale con molle, cinghie elastiche intrecciate, fibre vegetali e crine di cavallo, imbottitura in piuma d'oca e poliuretano espanso, rivestimento in tessuto e pelle. Basamento in ottone bronzato.

*Armchair with frame in beech, traditional suspension system on springs, interwoven elastic straps, vegetable fibres and horsehair, padding in goose feather and expanded polyurethane, covering in leather and fabric. Base in bronze-plated brass.*

## Art.314\_ERMELIN

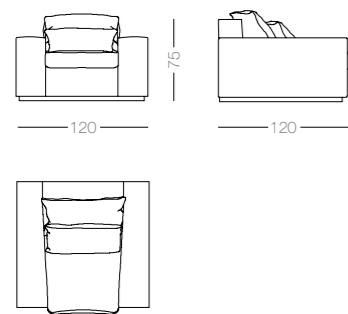

# Privé



Divano con fusto in legno di Faggio, sistema di molleggio tradizionale con molle, cinghie elastiche intrecciate, fibre vegetali e crine di cavallo, imbottitura in piuma d'oca e poliuretano espanso, rivestimento in tessuto e pelle. Piedini in ottone bronzato.

*Sofa with frame in beech, traditional suspension system on springs, interwoven elastic straps, vegetable fibres and horsehair, padding in goose feather and expanded polyurethane, covering in leather and fabric. Feet in bronze-plated brass.*



Art.202\_PRIVÉ

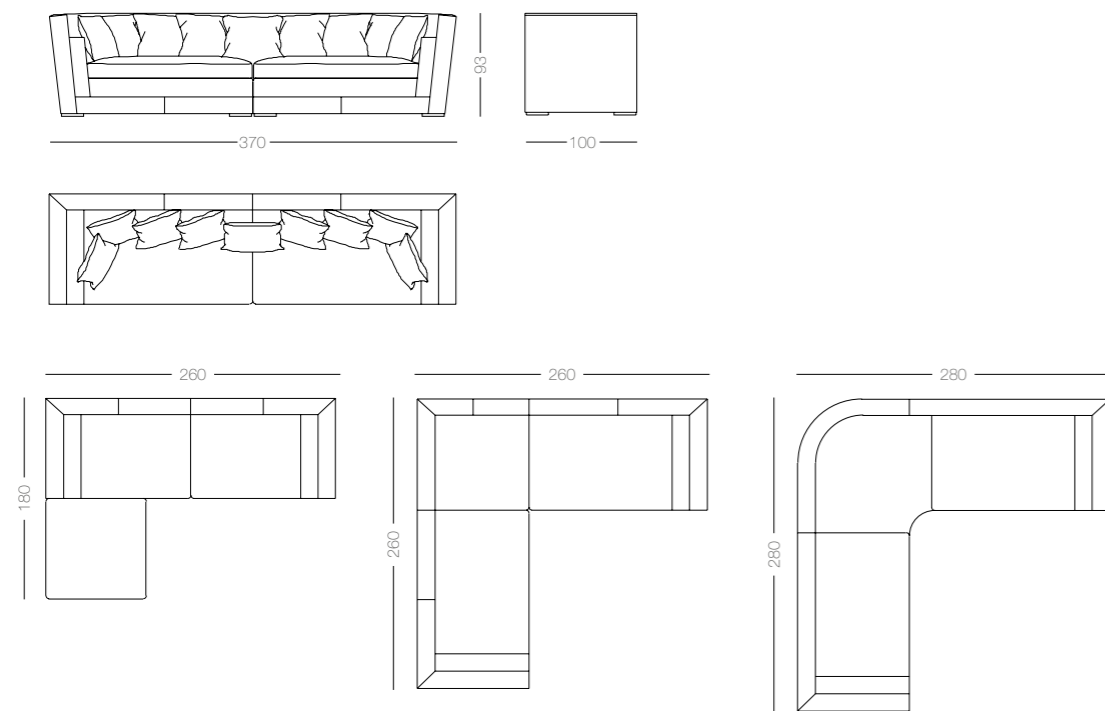

# Privé

Poltrona con fusto in legno di Faggio, sistema di molleggio tradizionale con molle, cinghie elastiche intrecciate, fibre vegetali e crine di cavallo, imbottitura in piuma d'oca e poliuretano espanso, rivestimento in tessuto e pelle. Piedini in ottone bronzato.

*Sofa with frame in beech, traditional suspension system on springs, interwoven elastic straps, vegetable fibres and horsehair, padding in goose feather and expanded polyurethane, covering in leather and fabric. Feet in bronze-plated brass.*

## Art.313\_PRIVÉ

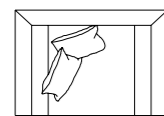
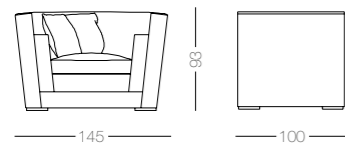

# Trevis



Divano con fusto in legno di Faggio, sistema di molleggio tradizionale con molle, cinghie elastiche intrecciate, fibre vegetali e crine di cavallo, imbottitura in piuma d'oca e poliuretano espanso, braccioli e schienale intrecciati a mano, rivestimento in velluto di seta.

*Sofa with frame in beech, traditional suspension system on springs, interwoven elastic straps, vegetable fibres and horsehair, padding in goose feather and expanded polyurethane, hand-interwoven armrests and backrest, covering in silk velvet.*

Art.203\_TREVIS

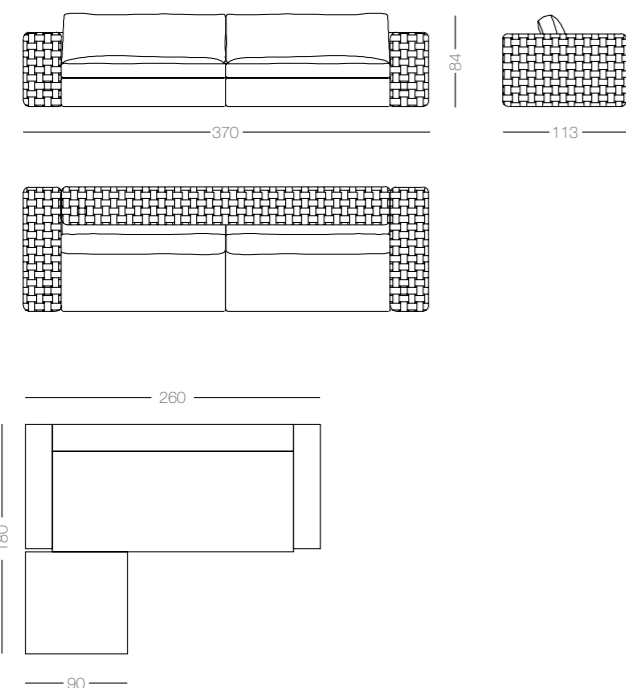

# Trevis



Poltrona con fusto in legno di Faggio, sistema di molleggio tradizionale con molle, cinghie elastiche intrecciate, fibre vegetali e crine di cavallo, imbottitura in piuma d'oca e poliuretano espanso, braccioli e schienale intrecciati a mano, rivestimento in velluto di seta.

*Armchair with frame in beech, traditional suspension system on springs, interwoven elastic straps, vegetable fibres and horsehair, padding in goose feather and expanded polyurethane, hand-interwoven armrests and backrest, covering in silk velvet.*

Art.308\_TREVIS

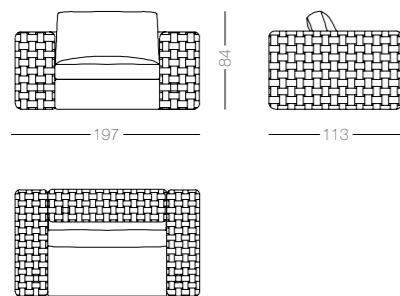

# Trevis



Pouf con struttura in legno, imbottitura in poliuretano, rivestito in velluto di seta, intreccio eseguito a mano e basamento in ottone bronzato.

*Pouf with wooden frame, padding in polyurethane, covering in silk velvet, handmade interweaving and base in bronze-plated brass.*

**Art.406\_TREVIS S**

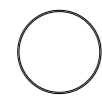
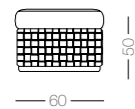

**Art.406\_TREVIS XL**

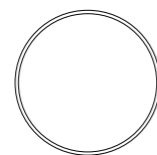
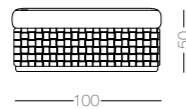



# Clero



Divano con fusto in legno di Faggio, sistema di molleggio tradizionale con molle, cinghie elastiche intrecciate, fibre vegetali e crine di cavallo, imbottitura in piuma d'oca e poliuretano espanso, rivestimento in Nubuck e cuscini in soffice piuma d'oca.

*Sofa with frame in beech, traditional suspension system on springs, interwoven elastic straps, vegetable fibres and horsehair, padding in goose feather and expanded polyurethane, covering in Nubuck and cushions in soft goose feather.*

**Art.204/A\_CLERO**

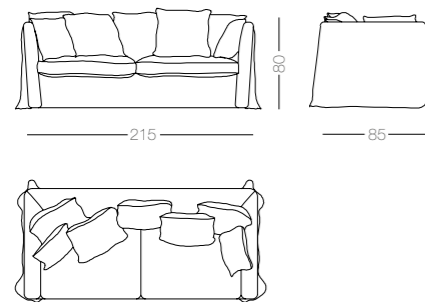

# Clero



Art.204/B\_CLERO

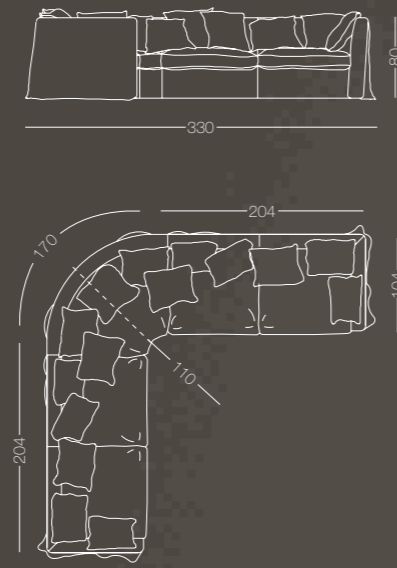

# Clero



Poltrona con fusto in legno di Faggio, sistema di molleggio tradizionale con molle, cinghie elastiche intrecciate, fibre vegetali e crine di cavallo, imbottitura in piuma d'oca e poliuretano espanso, rivestimento in Nubuck o pelle e cuscini in soffice piuma d'oca.

*Armchair with frame in beech, traditional suspension system on springs, interwoven elastic straps, vegetable fibres and horsehair, padding in goose feather and expanded polyurethane, covering in Nubuck or leather and cushions in soft goose feather.*

## Art.312\_CLERO

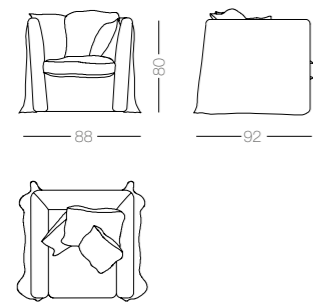

# Eloro



Divano con fusto in legno di Faggio, sistema di molleggio tradizionale con molle, cinghie elastiche intrecciate, fibre vegetali e crine di cavallo, imbottitura in piuma d'oca e poliuretano espanso, rivestimento in velluto e pelle. Basamento in ottone bronzato.

*Sofa with frame in beech, traditional suspension system on springs, interwoven elastic straps, vegetable fibres and horsehair, padding in goose feather and expanded polyurethane, covering in velvet and leather. Base in bronze-plated brass.*



**Art.205\_ELORO**

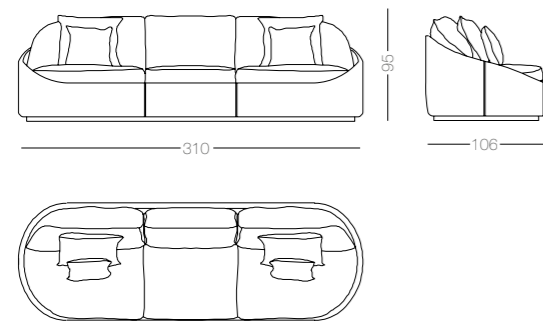

# Eloro



Divano con fusto in legno di Faggio, sistema di molleggio tradizionale con molle, cinghie elastiche intrecciate, fibre vegetali e crine di cavallo, imbottitura in piuma d'oca e poliuretano espanso, rivestimento in velluto e pelle. Basamento in ottone bronzato.

*Sofa with frame in beech, traditional suspension system on springs, interwoven elastic straps, vegetable fibres and horsehair, padding in goose feather and expanded polyurethane, covering in velvet and leather. Base in bronze-plated brass.*

**Art.307\_ELORO**

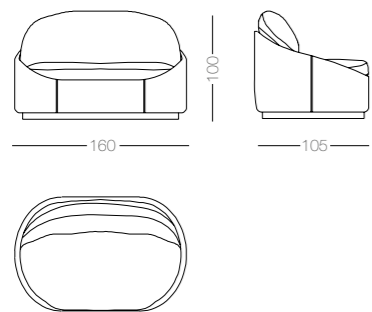

# Oxford



Divano con fusto in legno di Faggio, sistema di molleggio tradizionale con molle e cinghie elastiche intrecciate, imbottitura in poliuretano espanso. Rivestimento in tessuto e dettagli in pelle traforata con decoro brogue. Basamento in legno verniciato finitura ottone bronzato.

*Sofa with frame in Beech wood, traditional suspension system on springs and interwoven elastic straps, padding in expanded polyurethane. Covering in leather and details in perforated leather with brogue decoration. Base in lacquered wood with bronzed brass finish.*

Art.206\_OXFORD

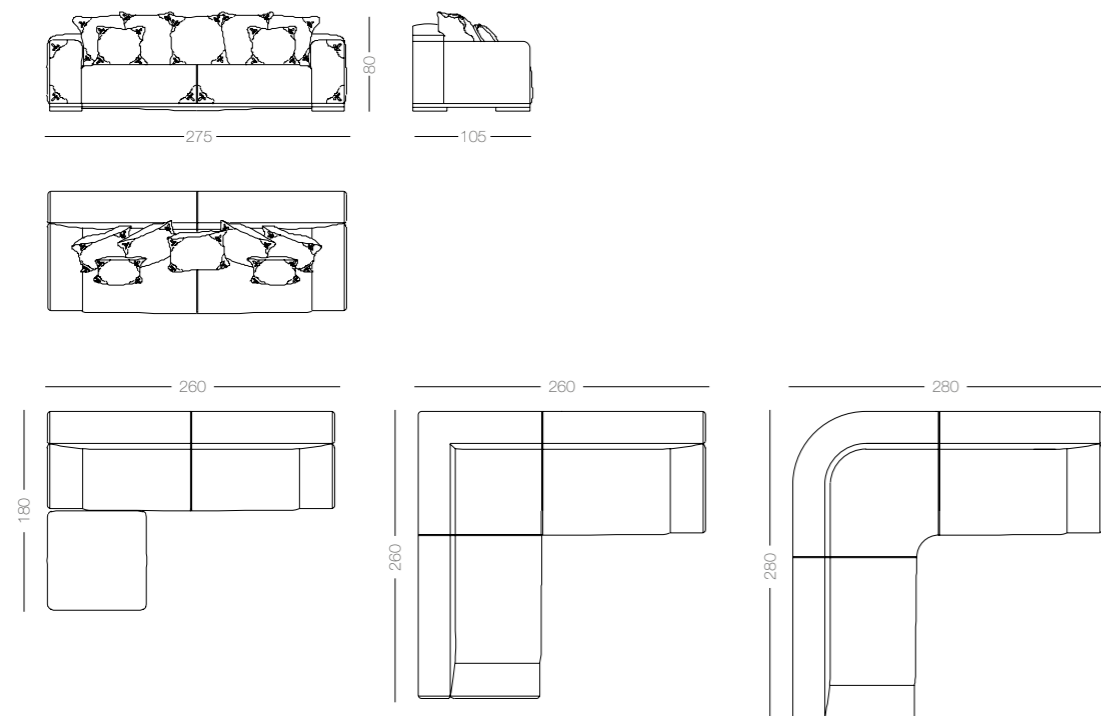

# Oxford



Poltrona con fusto in legno di Faggio, sistema di molleggio tradizionale con molle e cinghie elastiche intrecciate, imbottitura in poliuretano espanso. Rivestimento in tessuto e dettagli in pelle traforata con decoro brogue. Basamento in legno verniciato finitura ottone bronzato.

*Armchair with frame in Beech wood, traditional suspension system on springs and interwoven elastic straps, padding in expanded polyurethane. Covering in leather and details in perforated leather with brogue decoration. Base in lacquered wood with bronze-plated brass finish.*

**Art.311\_OXFORD**

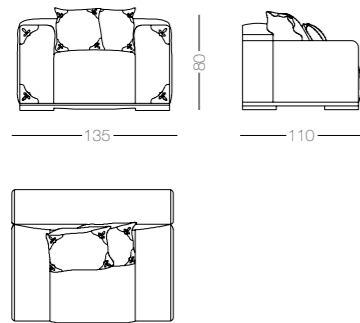

# Armony

Divano con fusto in legno di Faggio, sistema di molleggio tradizionale con molle, cinghie elastiche intrecciate, fibre vegetali e crine di cavallo. Imbottitura in piuma d'oca e poliuretano espanso, maxi cuscino in soffice piuma d'oca, rivestimento in velluto e lana. Basamento in ottone bronzato.

*Sofa with frame in Beech wood, traditional suspension system on springs, interwoven elastic straps, vegetable fibres and horsehair. Padding in goose feather and expanded polyurethane, and maxi cushion in soft goose feather, covering in velvet and wool. Base in bronze-plated brass.*

## Art.207\_ARMONY

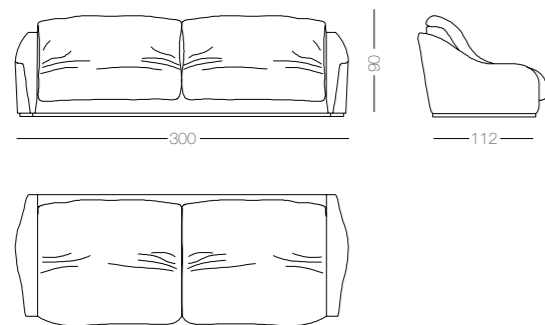



# Armony

Poltrona con fusto in legno di Faggio, sistema di molleggio tradizionale con molle, cinghie elastiche intrecciate, fibre vegetali e crine di cavallo. Imbottitura in piuma d'oca e poliuretano espanso, rivestimento in pelle. Basamento in ottone bronzato.

*Armchair with frame in beech, traditional suspension system on springs, interwoven elastic straps, vegetable fibre and horsehair. Padding in goose feather and expanded polyurethane, upholstered in leather. Base in bronze-plated brass.*

## Art.306\_ARMONY

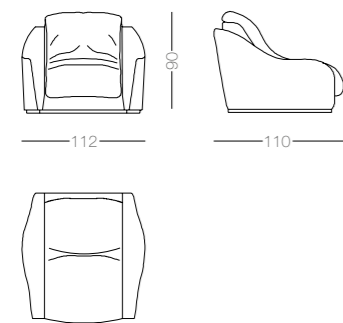

# Armony

Pouf con struttura in legno, imbottitura in poliuretano, rivestito in pelle.  
Basamento in ottone bronzato.

*Pouf with wooden frame, padding in polyurethane, covering in leather.  
Base in bronze-plated brass.*

## Art.405\_ARMONY

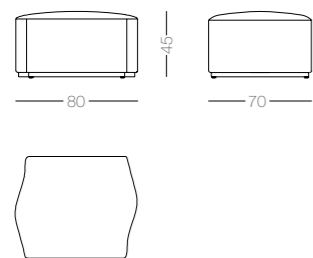

# Prometeo

Divano con fusto in legno di Faggio, sistema di molleggio tradizionale con molle, cinghie elastiche intrecciate, fibre vegetali e crine di cavallo, doppia imbottitura in piuma d'oca e poliuretano espanso, rivestimento in Nubuck e cuscini in soffice piuma d'oca. Basamento in ottone bronzato.

*Sofa with frame in beech, traditional suspension system on springs, interwoven elastic straps, vegetable fibres and horsehair, double padding in goose feather and expanded polyurethane, covering in Nubuck and cushions in soft goose leather, Base in bronze-plated brass.*

## Art.208\_PROMETEO

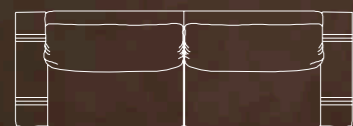

# Prometeo



Poltrona con fusto in legno di Faggio, sistema di molleggio tradizionale con molle, cinghie elastiche intrecciate, fibre vegetali e crine di cavallo, doppia imbottitura in piuma d'oca e poliuretano espanso, rivestimento in Nubuck e cuscini in soffice piuma d'oca. Basamento in ottone bronzato.

*Armchair with frame in beech, traditional suspension system on springs, interwoven elastic straps, vegetable fibres and horsehair, double padding in goose feather and expanded polyurethane, covering in Nubuck and cushions in soft goose leather. Base in bronze-plated brass.*

## Art.315\_PROMETEO

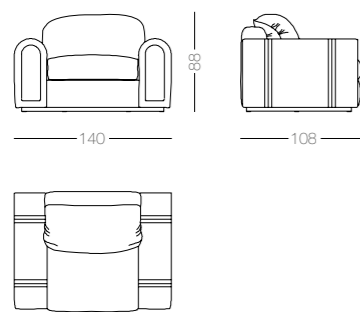

# Lord



Divano con fusto in legno di Faggio, sistema di molleggio tradizionale con molle, cinghie elastiche intrecciate, fibre vegetali e crine di cavallo, imbottitura in piuma d'oca e poliuretano espanso, rivestimento in Nubuck e cuscini in soffice piuma d'oca. Dettagli: schienale con lavorazione capitonné, frontale dei braccioli in Nubuck intrecciato e basamento in ottone bronzato.

*Sofa with frame in beech, traditional suspension system on springs, interwoven elastic straps, vegetable fibres and horsehair, padding in goose feather and expanded polyurethane, covering in Nubuck and cushions in soft goose leather. Details: backrest with beautiful button-tufting, front of armrests in interwoven Nubuck, and base in bronze-plated brass.*



**Art.209\_LORD**

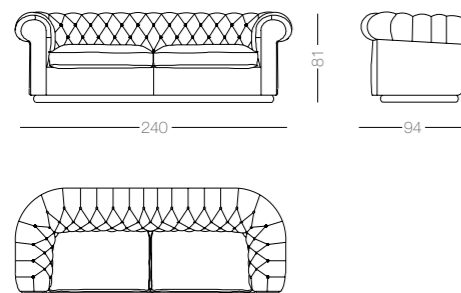

Art.212\_LORD

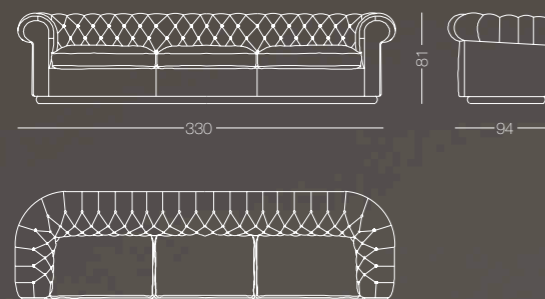

# Lord

Poltrona con fusto in legno di Faggio, sistema di molleggio tradizionale con molle, cinghie elastiche intrecciate, fibre vegetali e crine di cavallo, imbottitura in piuma d'oca e poliuretano espanso, rivestimento in Nubuck e cuscini in soffice piuma d'oca. Dettagli: schienale con lavorazione capitonné, frontale dei braccioli in Nubuck intrecciato e basamento in ottone bronzato.

*Armchair with frame in beech, traditional suspension system on springs, interwoven elastic straps, vegetable fibres and horsehair, padding in goose feather and expanded polyurethane, covering in Nubuck and cushions in soft goose leather. Details: backrest with beautiful button-tufting, front of armrests in interwoven Nubuck, and base in bronze-plated brass.*

## Art.316\_LORD

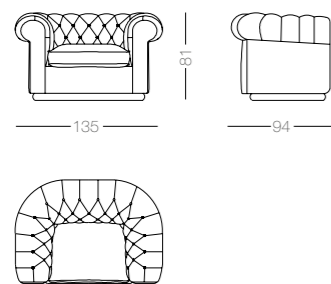

# Clessidra



Divano con fusto in legno di Faggio, sistema di molleggio tradizionale con molle, cinghie elastiche intrecciate, fibre vegetali e crine di cavallo, imbottitura in piuma d'oca e poliuretano espanso, rivestimento struttura in Nubuck, cuscini in soffice piuma d'oca rivestiti in velluto e basamento in ottone bronzato.

*Sofa with frame in Beech wood, traditional suspension system on springs, interwoven elastic straps, vegetable fibres and horsehair, padding in goose feather and expanded polyurethane, frame covering in Nubuck, cushions in soft goose leather with velvet covering and base in bronzed brass.*



**Art.211\_CLESSIDRA**

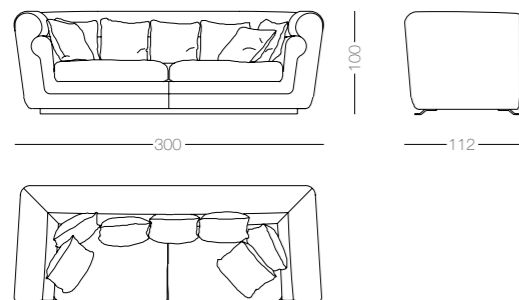

Nota bene:  
Prodotto non smontabile

*Take a notice:  
Product cannot be disassembled*



# Titano



Divano con fusto in legno di Faggio, sistema di molleggio tradizionale con molle, cinghie elastiche intrecciate, fibre vegetali e crine di cavallo. Struttura esterna rivestita in cuoio, cuscini seduta e schienale in velluto.

*Sofa with wooden frame in Beech, traditional suspension system, elastic interwoven straps, vegetable fibres and horsehair. External structure covered in thick leather, with seat and back cushions in velvet.*

Art.213/A\_TITANO

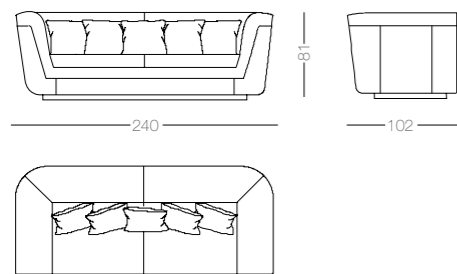

Nota bene:  
Prodotto non smontabile

*Take a notice:  
Product cannot be disassembled*



Art.213/B\_TITANO

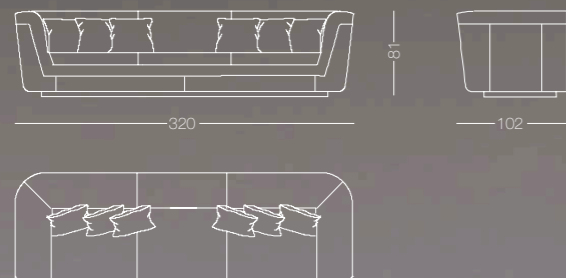

Nota bene:  
Prodotto non smontabile

*Take a notice:  
Product cannot be disassembled*



# Titano



Poltrona con fusto in legno di Faggio, sistema di molleggio tradizionale con molle, cinghie elastiche intrecciate, fibre vegetali e crine di cavallo. Struttura esterna rivestita in cuoio, cuscini seduta e schienale in velluto.

*Armchair with Beech wood frame, traditional suspension system on springs and interwoven elastic straps, padding in expanded polyurethane. Outer cover in Nubuck, back and seat in fabric. Perforated openwork with "brogue" pattern on the outer part of the armrests and backrest.*

## Art.318\_TITANO

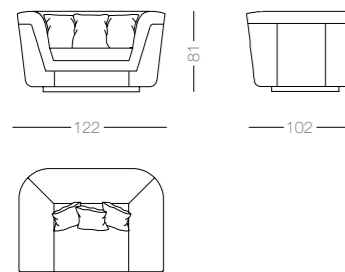

# Aura

Poltrona con fusto in legno di Faggio, sistema di molleggio tradizionale con molle, cinghie elastiche intrecciate, fibre vegetali e crine di cavallo, imbottitura in piuma d'oca e poliuretano espanso, rivestimento in Cashmere Cincillà.

*Armchair with frame in beech, traditional suspension system on springs, interwoven elastic straps, vegetable fibres and horsehair, padding in goose feather and expanded polyurethane, covering in Chinchilla Cashmere.*

## Art.302\_AURA

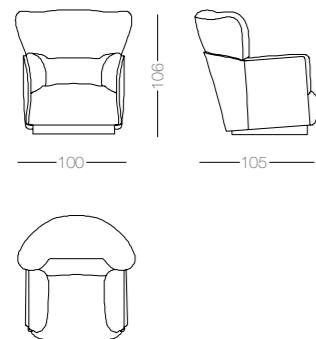

# Prissy II

Poltrona con fusto in legno di Faggio, sistema di molleggio tradizionale con molle, cinghie elastiche intrecciate, fibre vegetali e crine di cavallo, imbottitura in piuma d'oca e poliuretano espanso, rivestimento in pelle e Cashmere. Dettaglio: cucitura realizzata a mano tono su tono.

*Armchair with frame in beech, traditional suspension system on springs, interwoven elastic straps, vegetable fibres and horsehair, padding in goose feather and expanded polyurethane, covering in leather and Cashmere. Detail: handmade tone-on-tone stitching.*

## Art.303\_PRISSY II

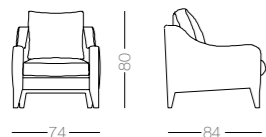

# Prissy

Pouf con struttura portante in legno, sistema di molleggio tradizionale con molle, cinghie elastiche intrecciate, fibre vegetali e crine di cavallo, imbottitura in piuma d'oca e poliuretano espanso, rivestimento in Cashmere.

*Pouf with supporting wooden frame, traditional suspension system on springs, interwoven elastic straps, vegetable fibres and horsehair, padding in goose feather and expanded polyurethane, covering in Cashmere.*

## Art.401\_PRISY

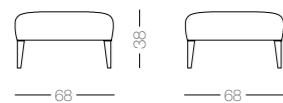

# Sophia



Poltrona con fusto in legno di Faggio, sistema di molleggio tradizionale con molle, cinghie elastiche intrecciate, fibre vegetali e crine di cavallo, imbottitura in piuma d'oca e poliuretano espanso, rivestimento in pelle.

*Armchair with frame in beech, traditional suspension system on springs, interwoven elastic straps, vegetable fibres and horsehair, padding in goose feather and expanded polyurethane, covering in leather.*

**Art.304\_SOPHIA**

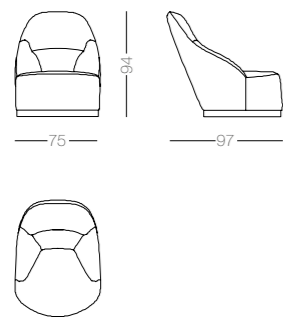

# Oxford



Poltrona con fusto in legno di Faggio, sistema di molleggio tradizionale con molle, cinghie elastiche intrecciate, fibre vegetali e crine di cavallo, imbottitura in piuma d'oca e poliuretano espanso, rivestimento in pelle e tessuto. Dettagli in pelle traforata con decoro brogue.

*Armchair with frame in beech, traditional suspension system on springs, interwoven elastic straps, vegetable fibres and horsehair, padding in goose feather and expanded polyurethane, covering in leather and Cashmere. Details in perforated leather with brogue decoration.*

**Art.305\_ OXFORD**

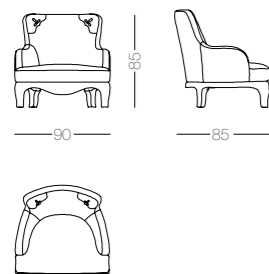



# Oxford Club

Poltrona con fusto in legno di Faggio, sistema di molleggio tradizionale con molle e cinghie elastiche intrecciate, imbottitura in poliuretano espanso. Rivestimento esterno in Nubuck, seduta e schienale in tessuto. Lavorazione traforata con decoro "brogue" su esterno braccioli e schienale.

*Armchair with Beech wood frame, traditional suspension system on springs and interwoven elastic straps, padding in expanded polyurethane. Outer cover in Nubuck, back and seat in fabric. Perforated openwork with brogue decoration on the outer part of the armrests and backrest.*

## Art.317\_ OXFORD CLUB

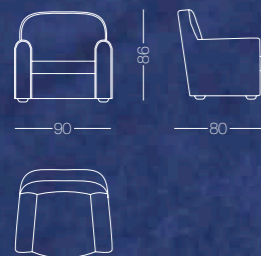

Boiserie

Sofas / Armchairs

**Poufs / Little Benches**

Coffee Tables

Tables

Chairs / Armchairs

Sideboards

Consoles

Showcases / Bookcases

Beds

Chests of Drawers / Bedside Tables / 6-Drawers units

Toilettes / Writing Desks / Dressing Tables

Walk-in Closets

Mirrors

Lamps

Accessories / Occasional Furniture

# Cubo



Pouf con struttura in legno rivestita esternamente e internamente in lino. Leggera imbottitura.

*Pouf with wooden frame, with external and internal linen covering. Light padding.*

**Art.402\_CUBO**

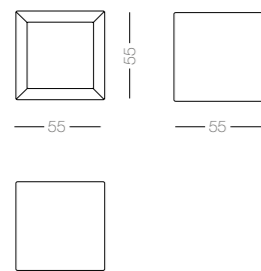

# Torquato



Pouf con struttura in legno, imbottitura in poliuretano, rivestita in velluto di seta, seduta con lavorazione capitonné.

*Pouf with wooden frame, polyurethane padding, covering in silk velvet, seat with beautiful button-tufting.*

**Art.403\_TORQUATO**

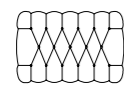
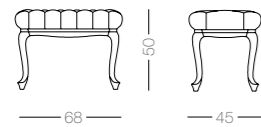

# Venere

Pouf con struttura in legno, sistema di molleggio tradizionale con molle, cinghie elastiche intrecciate, fibre vegetali e crine di cavallo, imbottitura in piuma d'oca e poliuretano espanso, rivestimento in velluto. Dettagli: trapuntatura e cuciture tono su tono. Basamento in ottone bronzato.

*Pouf with wooden frame, traditional suspension system on springs, interwoven elastic straps, vegetable fibres and horsehair, padding in goose feather and expanded polyurethane, covering in velvet. Details: quilting and tone-on-tone stitching. Base on bronze-plated brass.*

## Art.404\_VENERE

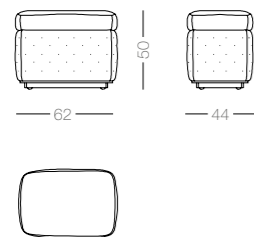

# Intrigo

Pouf con struttura in legno, imbottitura in poliuretano, rivestito in velluto di seta, intreccio eseguito a mano e basamento in ottone bronzato.

*Pouf with wooden frame, padding in polyurethane, covering in silk velvet, handmade interweaving and base in bronze-plated brass.*

## Art.407\_INTRIGO

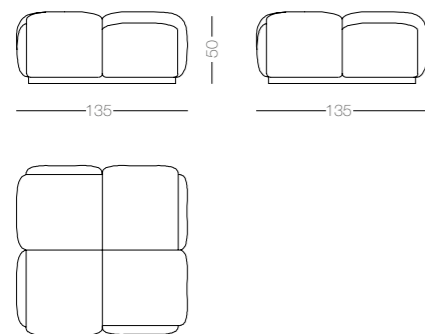

# Quadro

Pouf con struttura in legno, imbottitura in poliuretano, rivestito in pelle con cuciture eseguite a mano tono su tono. Basamento in ottone bronzato.

*Pouf with wooden frame, padding in polyurethane, covering in leather with handmade tone-on-tone stitchings. Base in bronze-plated brass.*

## Art.408\_QUADRO

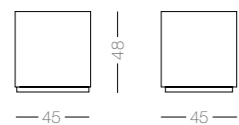

# Oxford



Panchetta con struttura in legno, imbottitura in poliuretano e piuma d'oca, rivestita in pelle, dettagli traforati con decoro brogue. Piedini in ottone bronzato.

*Bench with wooden frame, padding in polyurethane and goose feather, covering in leather, perforated details with brogue decoration. Feet in bronze-plated brass.*

**Art.409\_OXFORD**

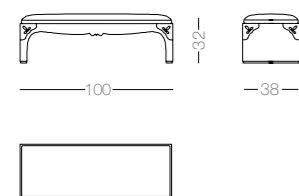



# Eclisse



Tavolino con struttura rotante in legno rivestita in Nubuck e scomparto portabottiglie, struttura semicircolare rotante in ottone bronzato.

*Small table with swivel frame in Nubuck covered wood and bottle storage area, semi-circular swivel frame in bronze-plated brass.*

**Art.410\_ECLISSE**

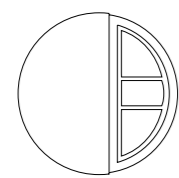
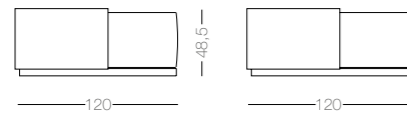

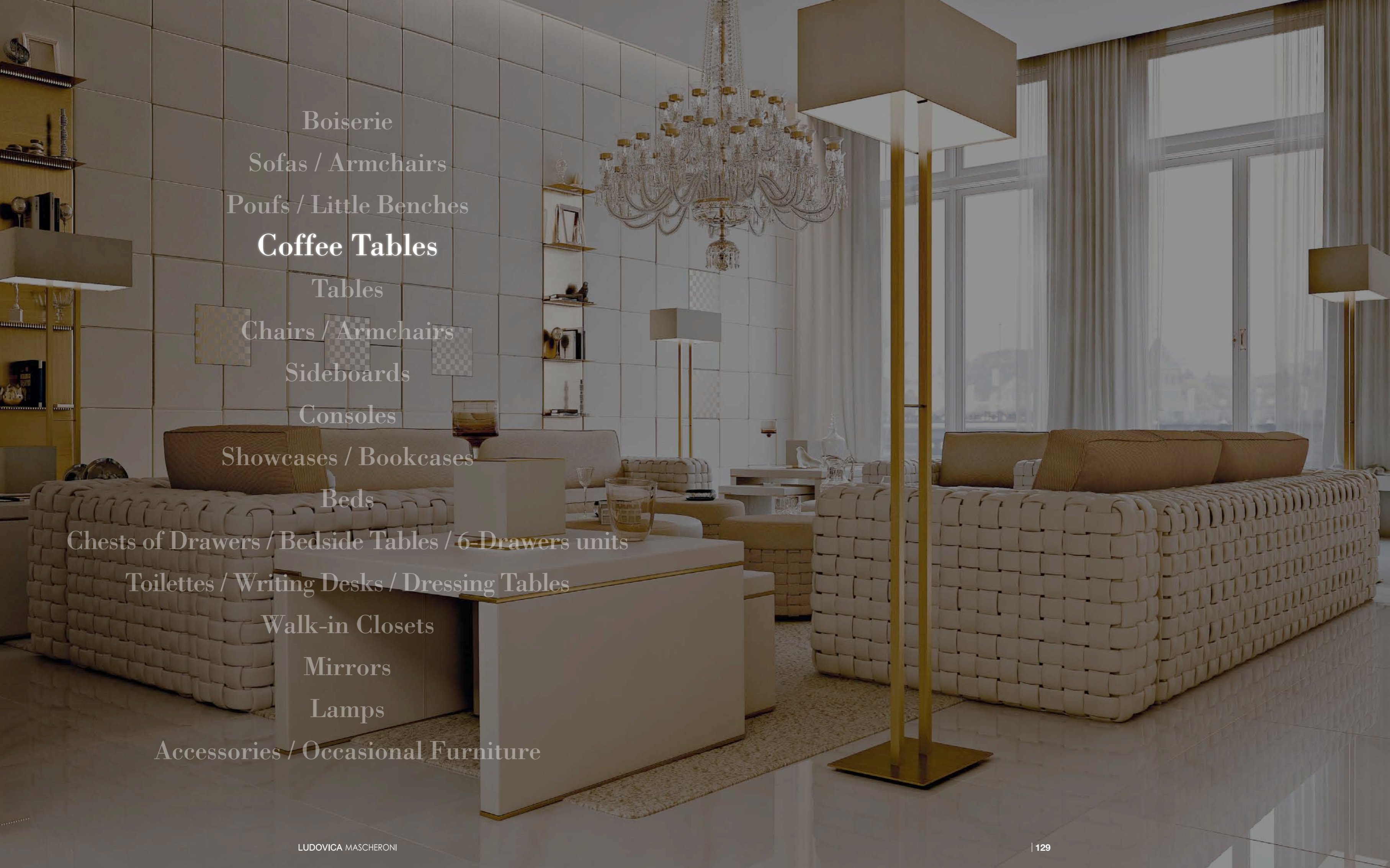

Boiserie

Sofas / Armchairs

Poufs / Little Benches

**Coffee Tables**

Tables

Chairs / Armchairs

Sideboards

Consoles

Showcases / Bookcases

Beds

Chests of Drawers / Bedside Tables / 6-Drawers units

Toilettes / Writing Desks / Dressing Tables

Walk-in Closets

Mirrors

Lamps

Accessories / Occasional Furniture

# Twin-Bridge



Coppia di tavolini con struttura in legno rivestita in pelle, piedini e inserti in ottone bronzato.

*Pair of small tables with wooden frame covered in leather, feet and inserts in bronze-plated brass.*

**Art.501\_TWIN-BRIDGE**

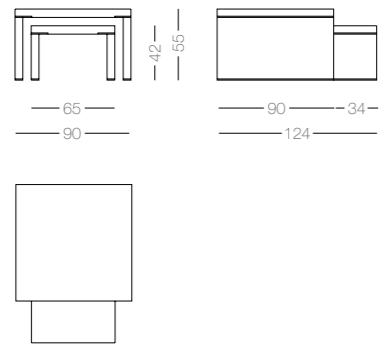

# Eliot



Tavolino con struttura in legno rivestita in Nubuck, piedini in ottone bronzato.

*Small table with wooden frame covered in Nubuck, feet in bronze-plated brass.*

**Art.502/A\_ELIOT**

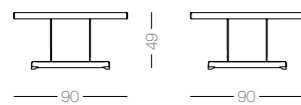

**Art.502/B\_ELIOT**

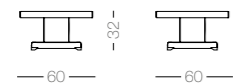

# Eloro



Tavolino con struttura in legno, gambe rivestite in pelle, piano in marmo Bronze Amani.

*Small table with wooden frame, legs covered in leather, top in Bronze Amani marble.*

**Art.503\_ELORO**

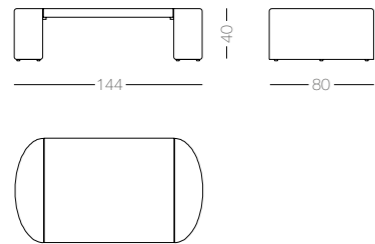

# Armony

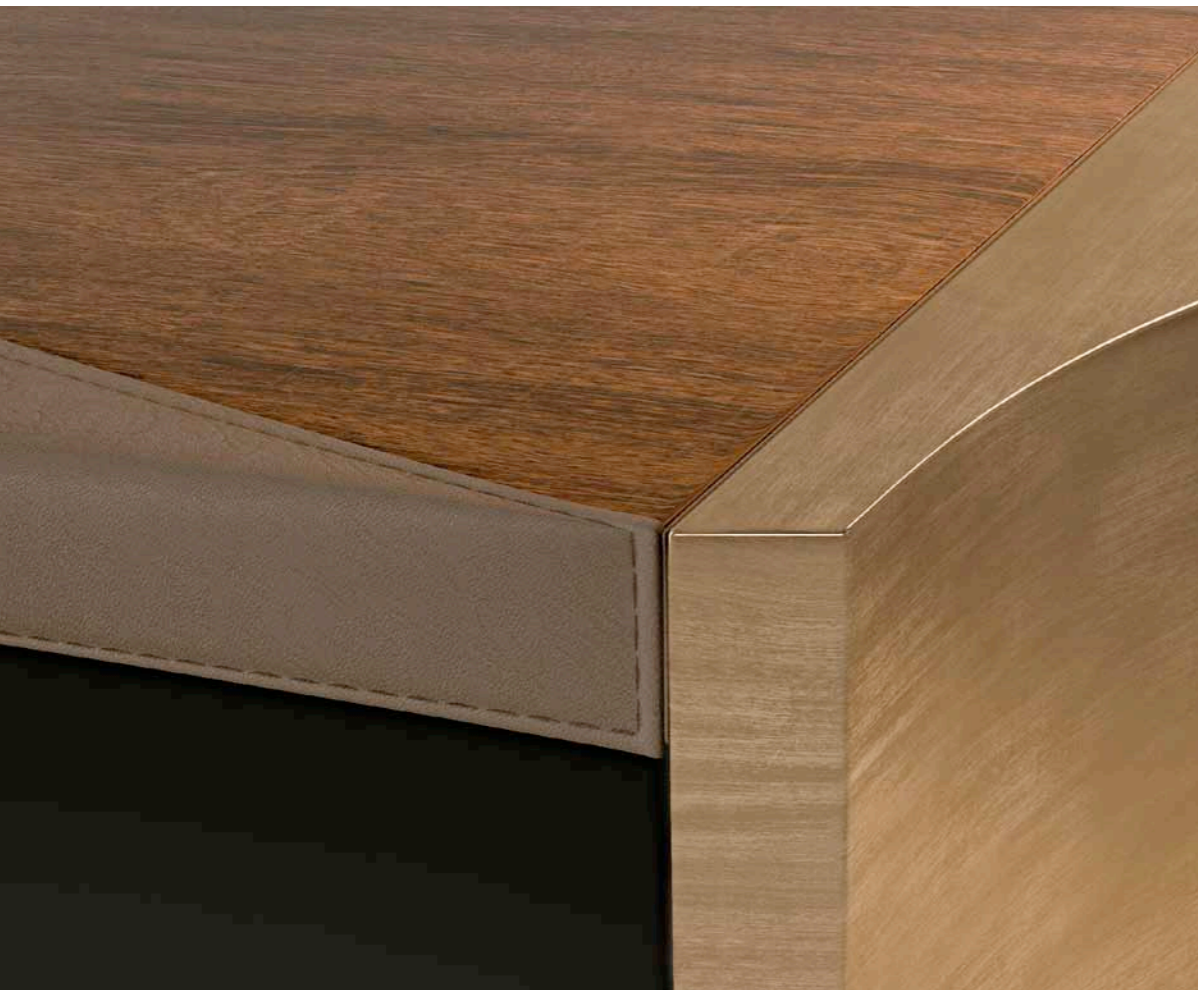

Tavolino con struttura in legno, gambe in ottone bronzato, piano in Noce Canaletto con inserti in pelle con cuciture eseguite a mano tono su tono.

*Small table with wooden frame, legs in bronze-plated brass, top in Canaletto Walnut with leather inserts with handmade tone-on-tone stitching.*

**Art.504\_ARMONY**

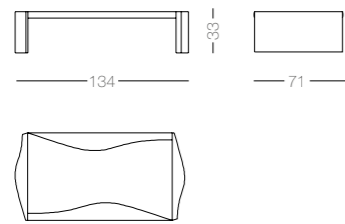

# Oxford



Tavolino con struttura in legno rivestita in pelle, angoli in pelle traforata con decoro brogue, piano in marmo Nero Assoluto, piedini e profilo in ottone bronzato.

*Small table with wooden frame covered in leather, corners in perforated leather with brogue decoration, top in Absolute Black marble, feet and profile in bronzed-plated brass.*

**Art.505\_OXFORD**

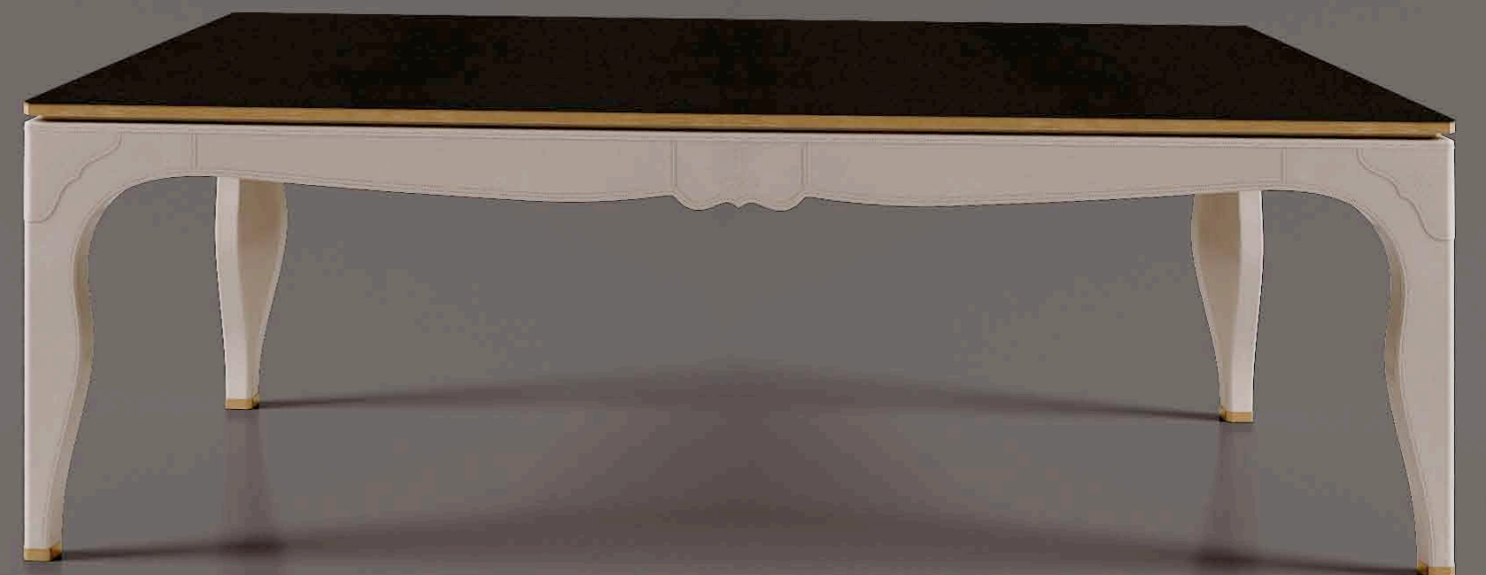
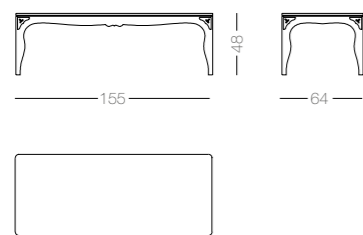

# Edra



Tavolino con struttura in legno rivestita in pelle, piano in marmo Crema Delicato, specchi interni. Cuciture eseguite a mano tono su tono.

*Small table with wooden frame covered in leather, Crema Delicato marble top, internal mirrors. Handmade tone-on-tone stitchings.*

Art.506\_EDRA

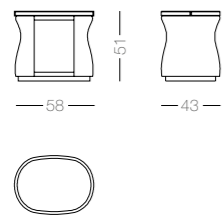



Boiserie

Sofas / Armchairs

Poufs / Little Benches

Coffee Tables

**Tables**

Chairs / Armchairs

Sideboards

Consoles

Showcases / Bookcases

Beds

Chests of Drawers / Bedside Tables / 6-Drawers units

Toilettes / Writing Desks / Dressing Tables

Walk-in Closets

Mirrors

Lamps

Accessories / Occasional Furniture

# Basilio



Tavolo con struttura in legno rivestito in Nubuck. Dettaglio gamba Chippendale.

*Table with wooden frame covered in Nubuck. Chippendale leg detail.*

**Art.601\_BASILIO**

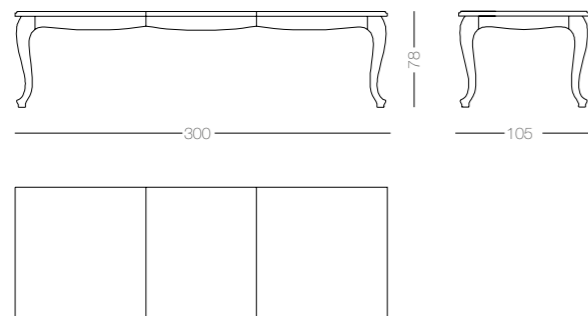

# Argo

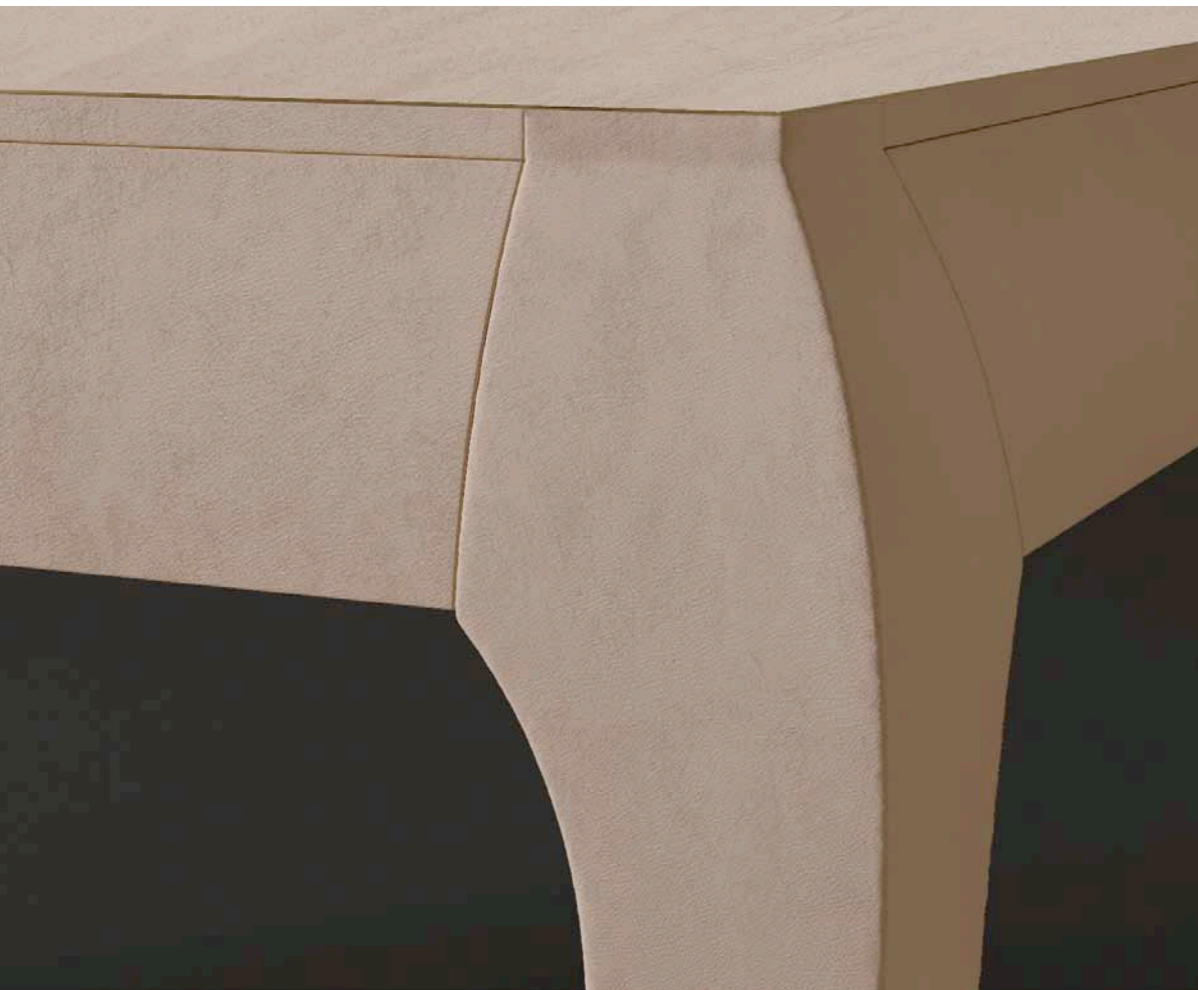

Tavolo con struttura in legno rivestito in Nubuck. Dettaglio gamba Chippendale.

*Table with wooden frame covered in Nubuck. Chippendale leg detail.*

**Art.602\_ARGO**

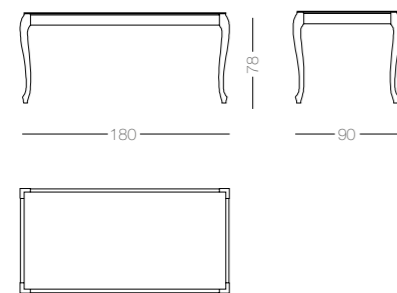

# Doralice

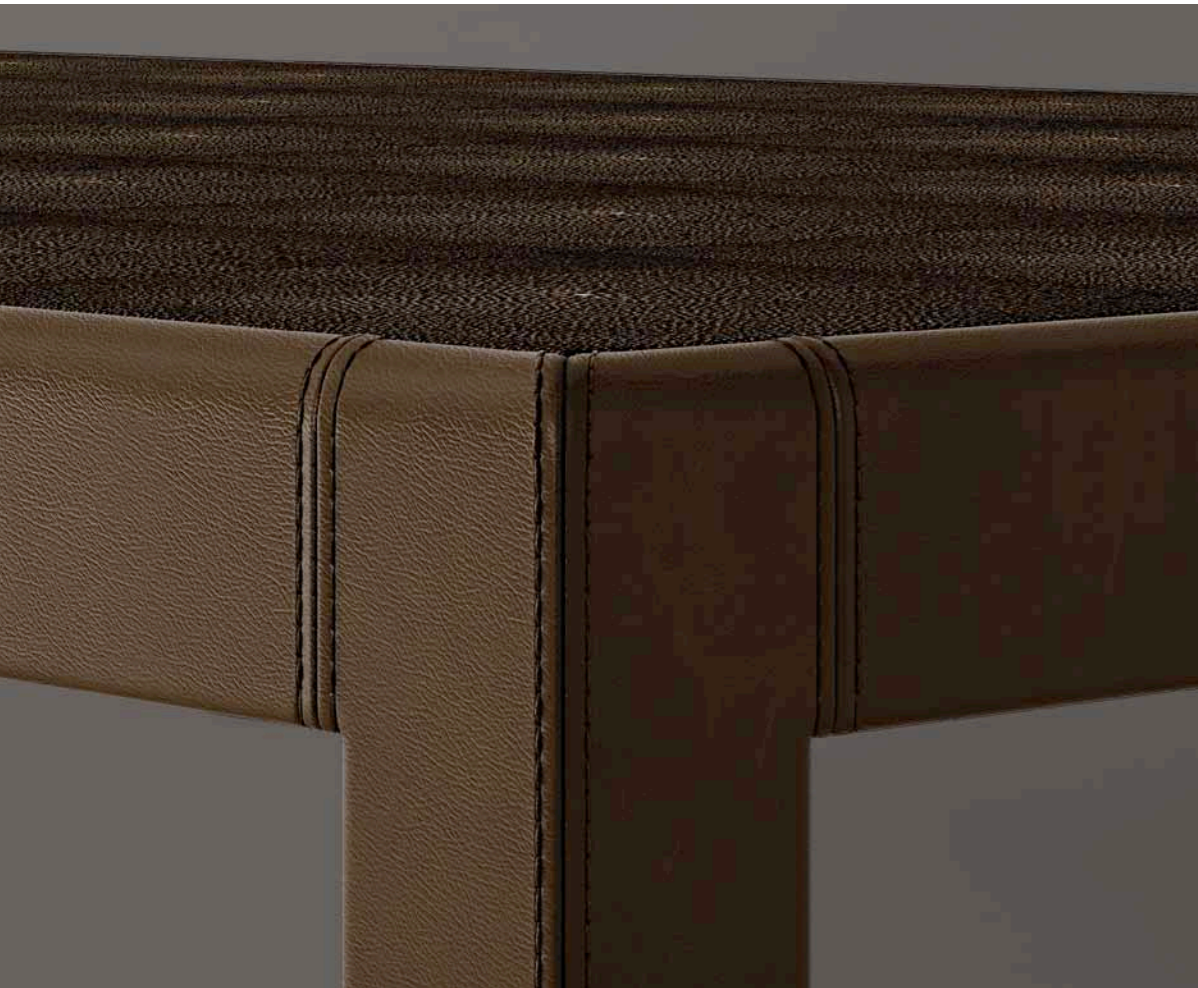

Tavolo con struttura in legno rivestito in pelle anilina, top in Galuchat. Cuciture realizzate a mano tono su tono.

*Table with wooden frame covered in aniline leather, top in Galuchat. Handmade tone-on-tone stitchings.*

**Art.603\_DORALICE**

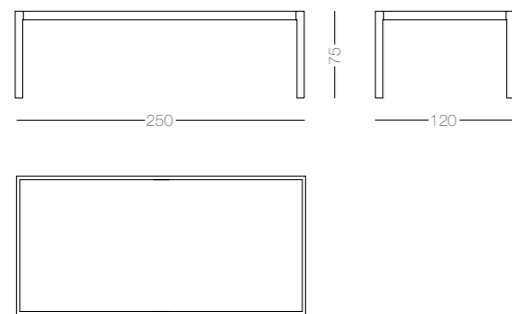

# Tolomeo



Tavolo con struttura in legno rivestito in Nubuck, base a corsetto in 100% lino.

*Table with wooden frame covered in Nubuck, corset-shaped base in 100% linen.*

**Art.604\_TOLOMEO**

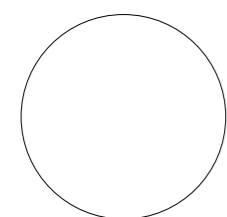
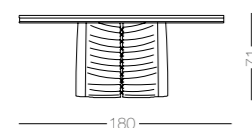

# Odeon

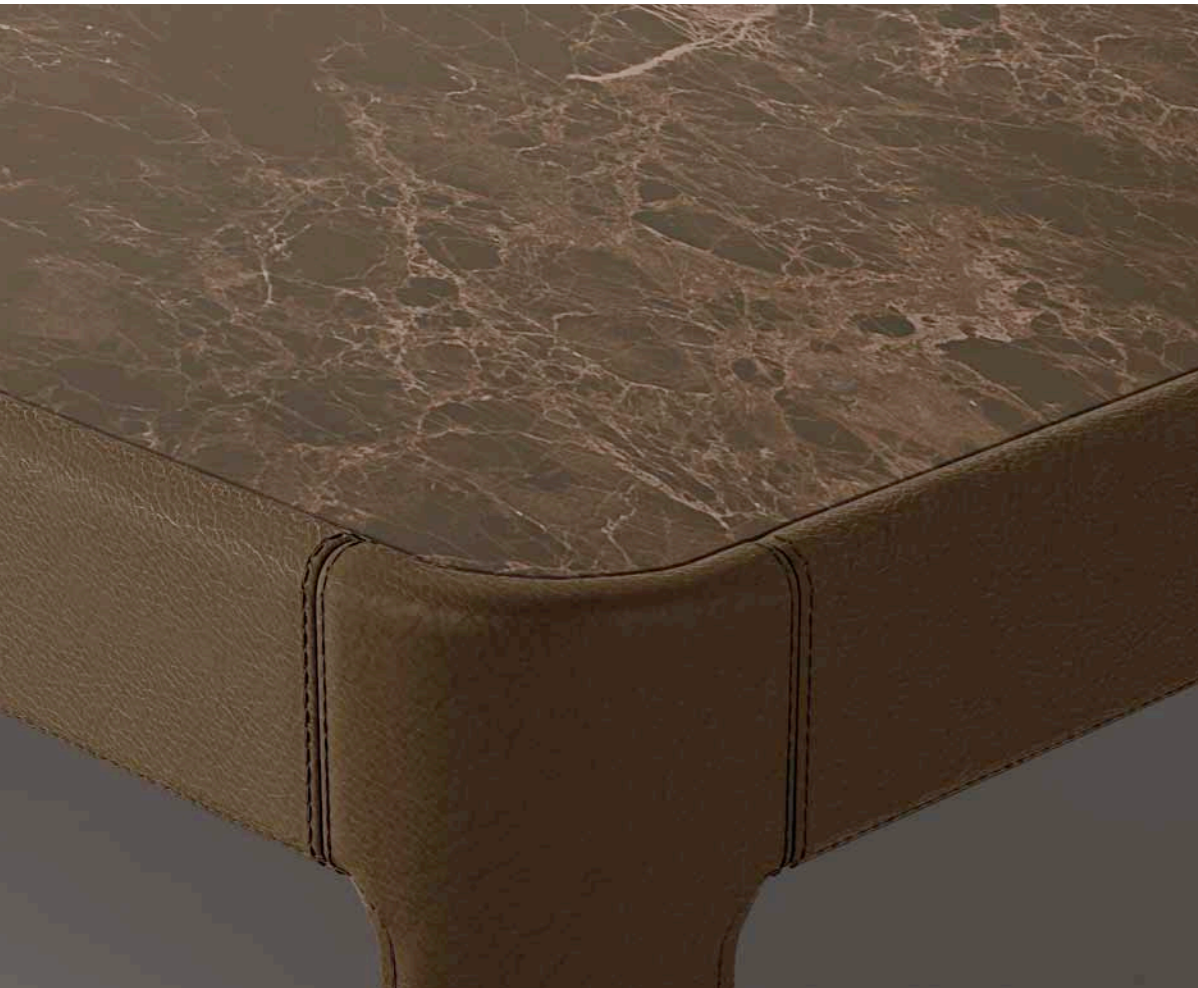

Tavolo con struttura in legno rivestito in pelle, piano in marmo Bronze Amani. Cuciture realizzate a mano tono su tono.

*Table with wooden frame covered in leather, top in Bronze Amani marble. Handmade tone-on-tone stitching.*

**Art.605\_ODEON**

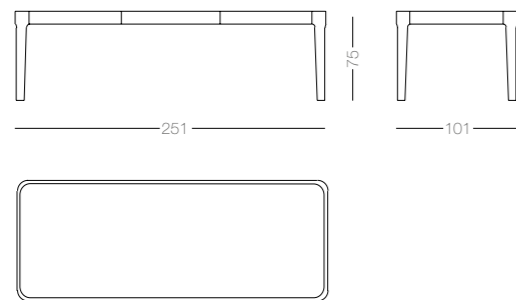

# Globo



Art.606\_GLOBO

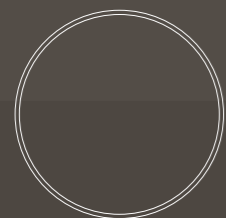
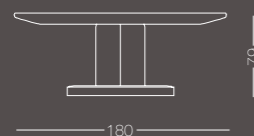

Tavolo con struttura in legno rivestito in pelle con cuciture a mano, piano in quarzite brasiliana. Basamento in ottone bronzato e dettaglio in pelle intrecciata a mano.

Table with wooden frame covered in leather, handmade stitching, and top in Brazilian quartzite. Base in bronze-plated brass and detail in hand-interwoven leather.

# Oxford



Tavolo con struttura in legno rivestito in pelle con cuciture a mano, dettagli traforati con decoro brogue, piano in marmo nero assoluto, profilo e piedini in ottone bronzato.

*Table with wooden frame covered in leather, handmade stitchings, perforated details with brogue decoration, top in Absolute Black marble, feet and profiles in bronze-plated brass.*

**Art.607\_OXFORD**

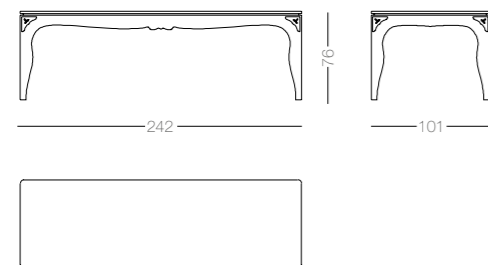



# Chelsea



Tavolo con struttura in legno rivestito in pelle con cuciture a mano. Dettagli traforati con decoro brogue, piano in marmo Emperador.

*Table with wooden frame covered in leather, stitching carried out by hand. Perforated details with brogue decoration and top in Emperador marble.*

**Art.608\_CHELSEA**

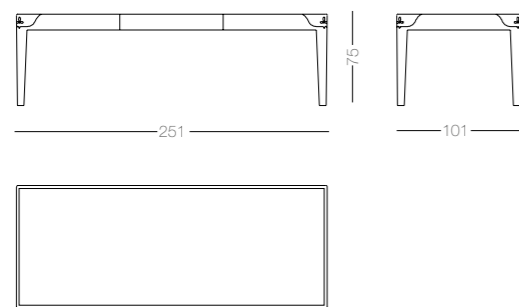

# Loto



Tavolo con struttura in legno di Acero, gambe rivestite in pelle con cuciture a mano tono su tono.

*Table with maple frame, legs covered in leather with handmade tone-on-tone stitching.*

**Art.609\_LOTO**

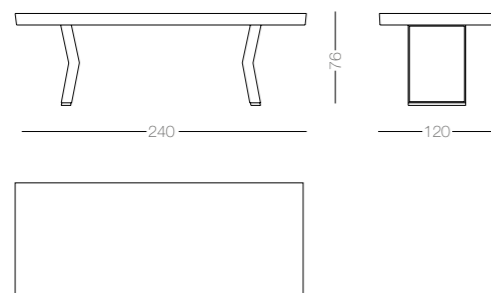

# Phoenix



Tavolo con gamba centrale in ottone bronzato e pelle intrecciati a mano. Piano in marmo Onice Miele. Basamento in legno rivestito in pelle con cuciture a mano tono su tono.

*Table with central leg in bronze-plated brass and interwoven leather, carried out by hand. Top in Honey Onyx marble. Wooden base covered in leather with handmade tone-on-tone stitchings.*

**Art.611\_PHOENIX**

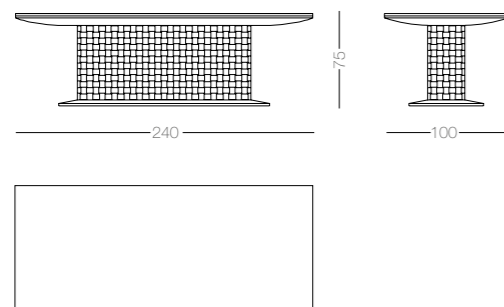

# Balmoral



Tavolo con struttura in legno rivestita in pelle con cuciture tono su tono. Piano in marmo Black & Gold, inserti e dettagli in ottone bronzato.

*Table with wooden frame covered in leather with tone-on-tone stitching. Black & Gold marble top, inserts and details in bronze-plated brass.*

Art.612\_BALMORAL

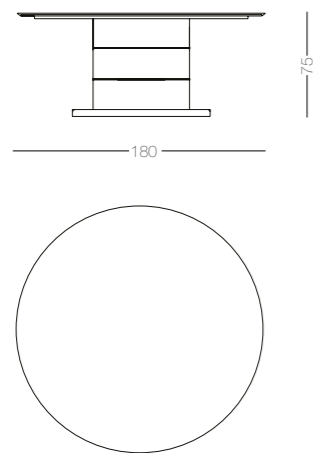

Boiserie

Sofas / Armchairs

Poufs / Little Benches

Coffee Tables

Tables

**Chairs / Armchairs**

Sideboards

Consoles

Showcases / Bookcases

Beds

Chests of Drawers / Bedside Tables / 6-Drawers units

Toilettes / Writing Desks / Dressing Tables

Walk-in Closets

Mirrors

Lamps

Accessories / Occasional Furniture

# Basilia

Poltroncina con struttura in legno, sistema di molleggio tradizionale con molle, cinghie elastiche intrecciate, fibre vegetali e crine di cavallo, imbottitura in piuma d'oca e poliuretano espanso, rivestita completamente in Nubuck.

*Armchair with wooden frame, traditional suspension system on springs, interwoven elastic straps, vegetable fibres and horsehair, padding in goose feather and expanded polyurethane, covered entirely in Nubuck.*

**Art. 701/P\_BASILIA**

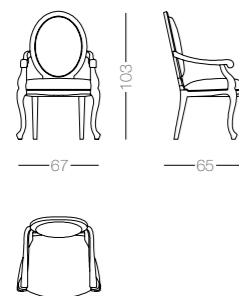

# Basilìa

Sedia con struttura in legno, sistema di molleggio tradizionale con molle, cinghie elastiche intrecciate, fibre vegetali e crine di cavallo, imbottitura in piuma d'oca e poliuretano espanso, rivestita completamente in Nubuck.

*Chair with wooden frame, traditional suspension system on springs, interwoven elastic straps, vegetable fibres and horsehair, padding in goose feather and expanded polyurethane, covered entirely in Nubuck.*

## Art. 701\_BASILIA

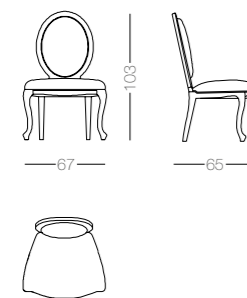

---

# Fantasma





# Fantasma



Sedia con struttura in legno, sistema di molleggio tradizionale con molle, cinghie elastiche intrecciate, fibre vegetali e crine di cavallo, imbottitura in piuma d'oca e poliuretano espanso, rivestita in Nubuck, schienale e seduta in 100% Cashmere.

*Chair with wooden frame, traditional suspension system on springs, interwoven elastic straps, vegetable fibres and horsehair, padding in goose feather and expanded polyurethane, covering in Nubuck, backrest and seat in 100% Cashmere.*

## Art. 702\_FANTASMINA

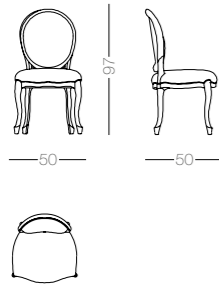

# Fantasma



Poltroncina con struttura in legno, sistema di molleggio tradizionale con molle, cinghie elastiche intrecciate, fibre vegetali e crine di cavallo, imbottitura in piuma d'oca e poliuretano espanso, rivestita in Nubuck, schienale e seduta in 100% Cashmere.

*Armchair with wooden frame, traditional suspension system on springs, interwoven elastic straps, vegetable fibres and horsehair, padding in goose feather and expanded polyurethane, covering in Nubuck, backrest and seat in 100% Cashmere.*

**Art.702/P\_FANTASMINA**

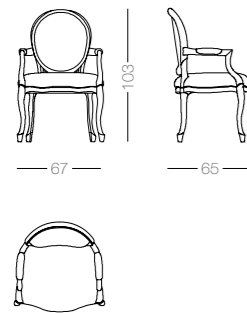

# Fantasma



Divanetto con struttura in legno, sistema di molleggio tradizionale con molle, cinghie elastiche intrecciate, fibre vegetali e crine di cavallo, imbottitura in piuma d'oca e poliuretano espanso completamente rivestita in Nubuck.

*Small sofa with wooden frame, traditional suspension system on springs, interwoven elastic straps, vegetable fibres and horsehair, padding in goose feather and expanded polyurethane, covered entirely in Nubuck.*

## Art. 702/D\_FANTASMINA

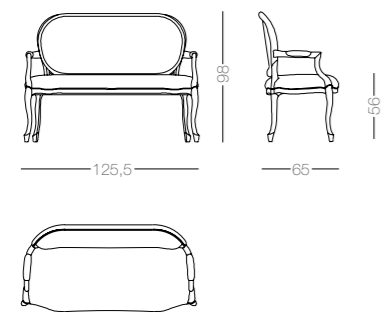

# Doralice



Sedia con struttura in legno, imbottitura in poliuretano espanso, rivestimento in velluto di seta, lavorazione intreccio realizzata a mano. Dettaglio: maniglia rivestita in pelle sullo schienale.

*Chair with wooden frame, padding in expanded polyurethane, covering in silk velvet, handmade interweaving. Detail: handle covered in leather on the backrest.*



Art.703\_DORALICE

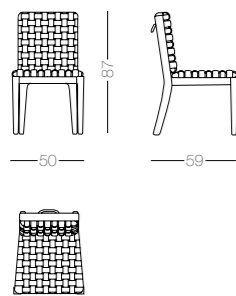

# Artemide



Sedia con struttura in legno, imbottitura in poliuretano espanso, rivestimento in pelle e tessuto.  
Chair with wooden frame, padding in expanded polyurethane, covering in leather and fabric.

**Art.704\_ARTEMIDE**

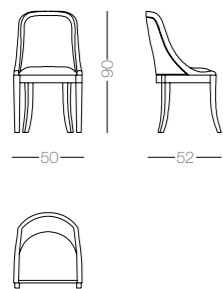

# Odeon

Sedia con struttura in legno, imbottitura in poliuretano espanso, rivestimento in pelle e seduta con lavorazione capitonné.

*Chair with wooden frame, padding in expanded polyurethane, covering in leather and button-tufted seat.*

**Art. 705\_ODEON**

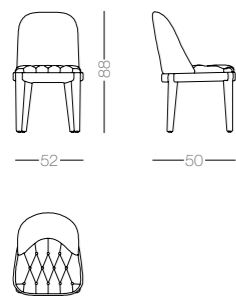

# Luna



Poltroncina con struttura in legno curvato rivestita in pelle. Seduta imbottita in poliuretano espanso e rivestita in pelle intrecciata a mano, cuciture tono su tono e basamento in ottone bronzato.

*Small armchair with bent wooden frame and upholstered in leather. Seat padded in expanded polyurethane and covered in hand-interwoven leather with tone-on-tone stitching and base in bronze-plated brass.*

Art.706\_LUNA

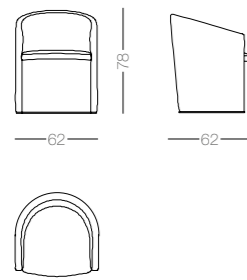

# Loto



Sedia con struttura in legno, rivestita in velluto con dettagli floreali in pregiata pelle di Capretto.

Chair with wooden frame covered in velvet with floral details in fine Kid leather.

**Art.707/A\_LOTO**

**Art.707/B\_LOTO**

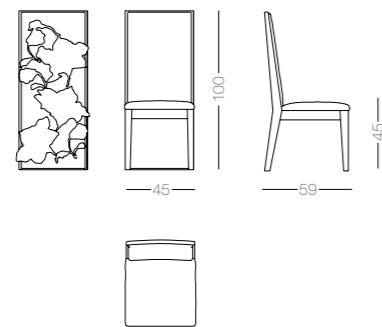
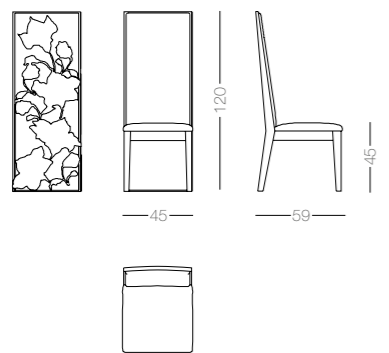



# Oxford



Sedia con struttura in legno, imbottitura in poliuretano espanso rivestita in pelle e tessuto. Dettagli traforati con decoro brogue.

*Chair with wooden frame, padding in expanded polyurethane, covered in leather and fabric. Perforated details with brogue decoration.*

**Art.708\_oxford**

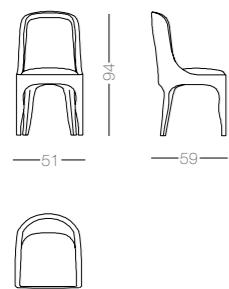

# Oxford



Poltrona con struttura in legno, sistema di molleggio tradizionale con cinghie elastiche intrecciate, imbottitura in poliuretano espanso, rivestimento in pelle e tessuto. Dettagli in pelle traforata con decoro brogue e basamento girevole in ottone bronzato.

*Armchair with wooden frame, traditional suspension system with interwoven elastic straps, padding in expanded polyurethane, covering in leather and fabric. Details in perforated leather with brogue decoration and swivel base in bronze-plated brass.*

**Art.309\_ OXFORD**

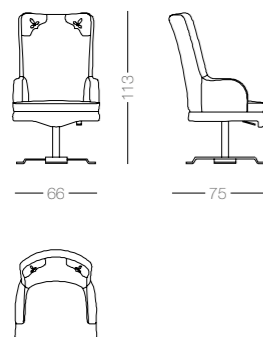

# Oxford

Poltrona con struttura in legno, sistema di molleggio tradizionale con cinghie elastiche intrecciate, imbottitura in poliuretano espanso, rivestimento in pelle e tessuto. Dettagli in pelle traforata con decoro brogue.

*Armchair with wooden frame, traditional suspension system with interwoven elastic straps, padding in expanded polyurethane, covering in leather and fabric. Details in perforated leather with brogue decoration.*

## Art.310\_ OXFORD

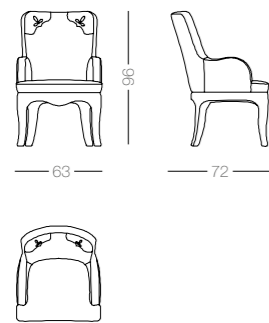

# Chelsea

Sedia con struttura in legno, imbottitura in poliuretano espanso. Interamente rivestita in pelle. Dettagli traforati con decoro brogue.

*Chair with wooden frame, padding in expanded polyurethane. Entirely covered in leather. Perforated details with brogue decoration.*

## Art. 709\_CHELSEA

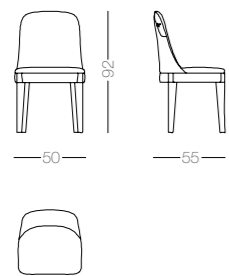

# Phoenix



Poltroncina con struttura in legno, imbottitura in poliuretano espanso, rivestita in pelle. Dettagli: profilo e piedini in ottone bronzato.

*Armchair with wooden frame, padding in expanded polyurethane covered in leather. Details: profile and feet in bronze-plated brass.*

Art. 710\_PHOENIX

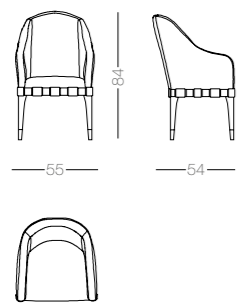

# Balmoral

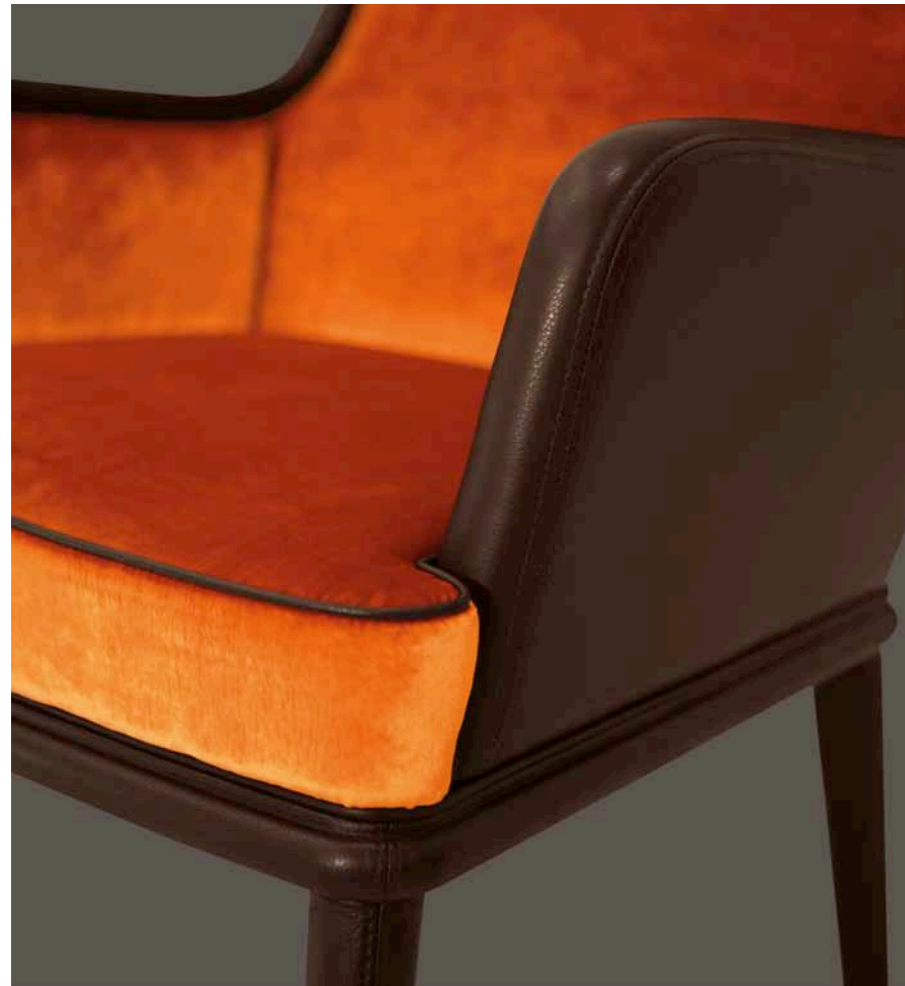

Poltroncina con struttura in legno, imbottita in poliuretano espanso, esterno rivestito in pelle con cuciture tono su tono. Schienale e seduta in velluto, piedini in ottone bronzato.

*Small armchair with wooden frame, padding in expanded polyurethane, external covered in leather with tone-on-tone stitching. Backrest and seat in velvet, legs in bronze-plated brass.*

Art. 711\_BALMORAL

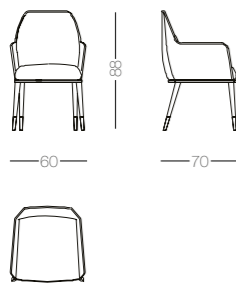

Boiserie

Sofas / Armchairs

Poufs / Little Benches

Coffee Tables

Tables

Chairs / Armchairs

**Sideboards**

Consoles

Showcases / Bookcases

Beds

Chests of Drawers / Bedside Tables / 6-Drawers units

Toilettes / Writing Desks / Dressing Tables

Walk-in Closets

Mirrors

Lamps

Accessories / Occasional Furniture

# Doralice

Credenza con struttura in legno rivestita in pelle anilina, top in Galuchat, interni e ante rivestite in pelle con cucitura a mano tono su tono. Basamento in ottone bronzato.

*Sideboard with wooden frame covered in aniline leather, top in Galuchat, doors and interior covering in leather with handmade tone-on-tone stitching. Base in bronze-plated brass.*



**Art.801/A\_DORALICE**

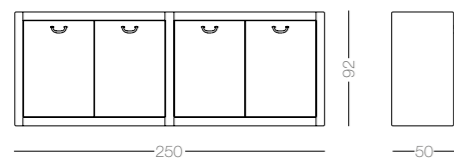

**Art.801/B\_DORALICE**

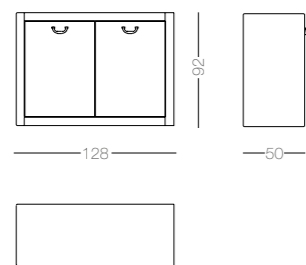



# Odeon



Credenza con struttura in legno, rivestita esternamente ed internamente in pelle. Ante impunturate. Top in marmo Bronze Amani e basamento in ottone bronzato.

*Sideboard with wooden frame, exterior and interior covering in leather. Backstitching on doors. Top in Amani Bronze marble and base in bronze-plated brass.*

**Art.802/A\_ODEON**

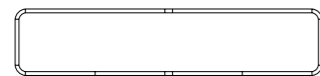
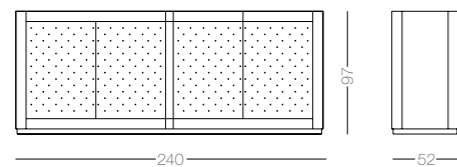

**Art.802/B\_ODEON**

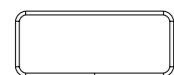
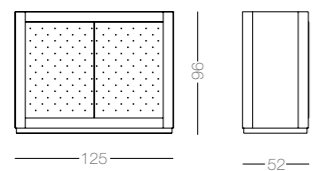

# Loto



Credenza con struttura in legno di Acero, ante rivestite in pelle con leggera imbottitura e cuciture a mano tono su tono.

*Sideboard with frame in Maple, doors covered in leather with light padding and handmade tone-on-tone stitching.*

**Art.803/A\_LOTO**

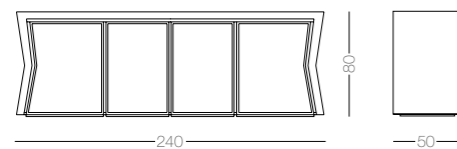

**Art.803/B\_LOTO**

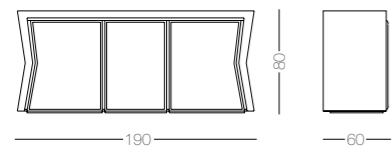

# Oxford



Credenza con struttura in legno, top in marmo nero assoluto, dettagli in pelle traforata con decoro brogue, frontali cassetti e ante rivestite in cotone misto lino, basamento e profilo top in ottone bronzato.

*Sideboard with wooden frame, top in "absolute black" marble, details in perforated leather with brogue decoration, drawer fronts and doors covered in cotton-linen blend, base and top edging in bronze-plated brass.*

**Art.804/A\_oxford**

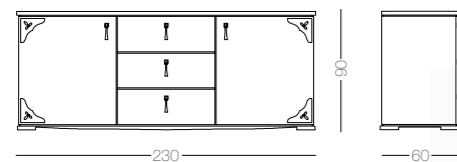

**Art.804/B\_oxford**

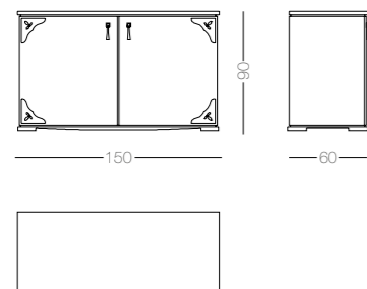

# Oxford



Credenza con struttura in legno, top in marmo nero assoluto, dettagli in pelle traforata con decoro brogue, ante rivestite in cotone misto lino, basamento e profilo top in ottone bronzato.

*Sideboard with wooden frame, top in "absolute black" marble, details in perforated leather with brogue decoration, drawer fronts and doors covered in cotton-linen blend, base and top edging in bronze-plated brass.*

Art.806\_OXFORD

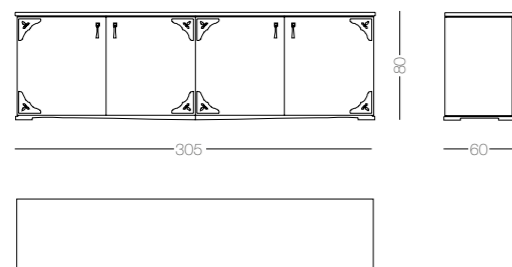

# Dorian

Credenza con struttura in legno rivestita in pelle, illuminazione interna a Led, base e cornice in ottone bronzato.

*Sideboard with wooden frame covered in leather, LED interior lighting, base and edging in bronze-plated brass.*

**Art.805\_DORIAN**

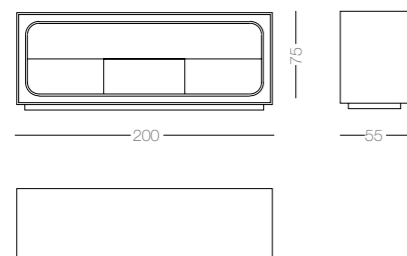

# Phoenix



Credenza con struttura in legno, top in marmo Onice Miele, ante con lavorazione ad intreccio in pelle e ottone bronzato realizzato a mano, mensole interne rivestite in pelle impunturata ed essenza Sucupira, basamento in pelle e ottone bronzato.

*Sideboard with wooden frame, top in Honey Onyx marble, doors with interwoven leather and bronze-plated brass, both carried out by hand, as well as internal shelves covered in backstitched leather and Sucupira wood, base in leather and bronze-plated brass.*

Art.807\_PHOENIX

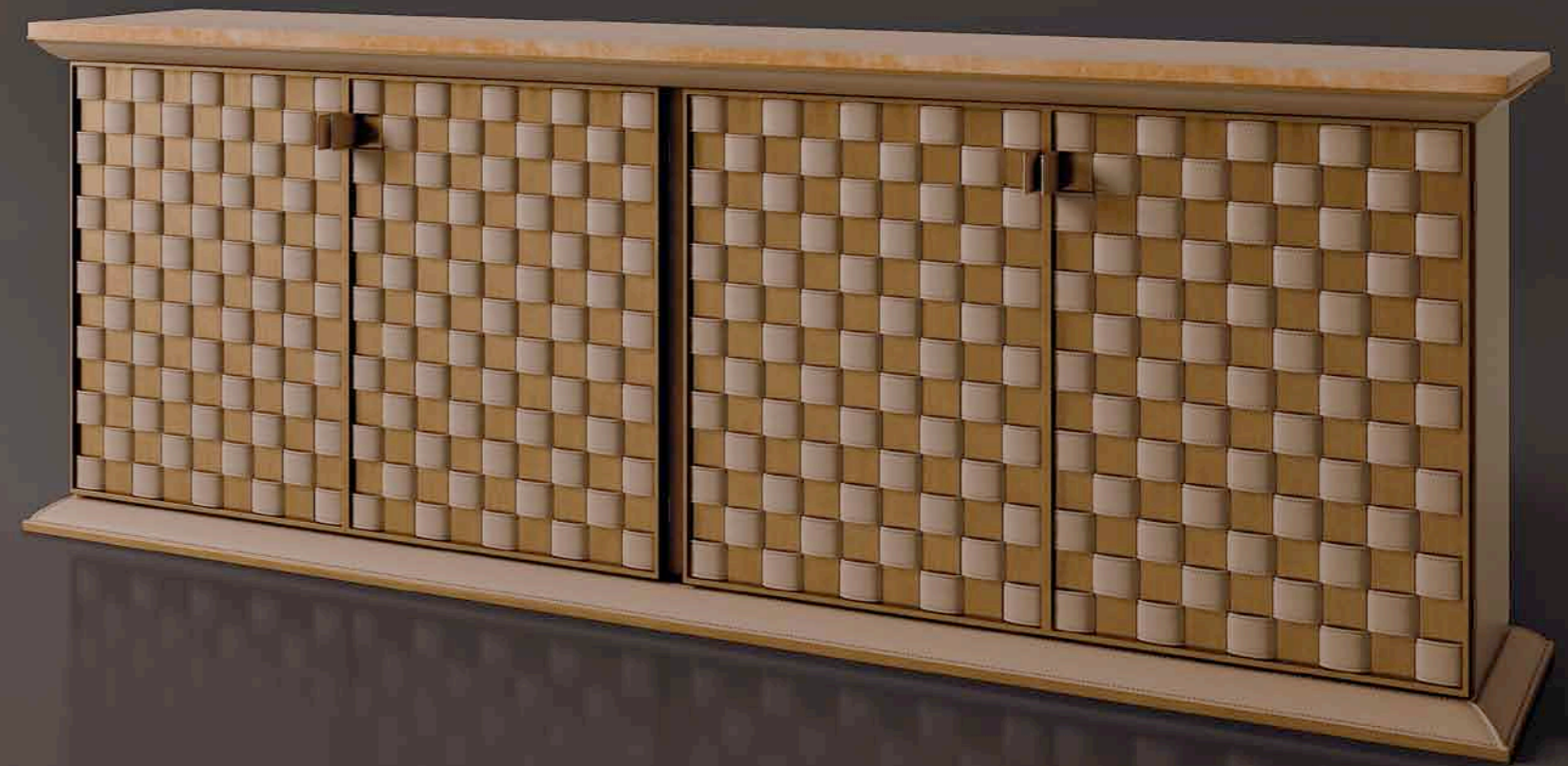
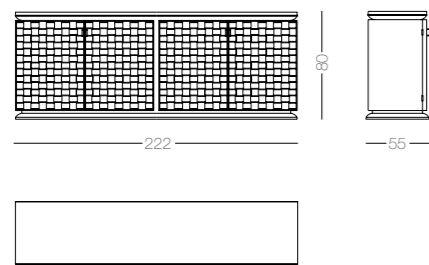

# Balmoral



Credenza con struttura in legno rivestita in pelle con cuciture tono su tono, interno in essenza Ziricote laccato lucido poliестere. Top in marmo Black & Gold. Inserti e maniglie in ottone bronzato. Illuminazione led interna con sensore di apertura.

*Sideboard with wooden frame covered in leather with tone-on-tone stitching, interior in Ziricote wood with glossy lacquered polyester finish. Black & Gold marble top. Inserts and handles in bronze-plated brass. LED interior lighting with opening sensors.*

Art.808\_BALMORAL

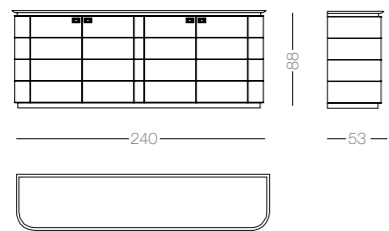

Boiserie

Sofas / Armchairs

Poufs / Little Benches

Coffee Tables

Tables

Chairs / Armchairs

Sideboards

**Consoles**

Showcases / Bookcases

Beds

Chests of Drawers / Bedside Tables / 6-Drawers units

Toilettes / Writing Desks / Dressing Tables

Walk-in Closets

Mirrors

Lamps

Accessories / Occasional Furniture



# Basilia



Consolle con struttura in legno rivestita interamente in Nubuck, dettaglio gamba Chippendale.

*Console with wooden frame entirely covered in Nubuck. Chippendale leg detail.*

**Art.901\_BASILIA**

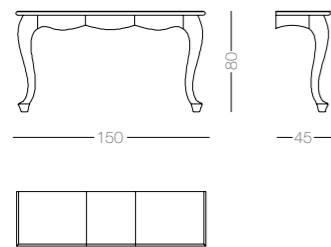

# Altai



Consolle con struttura in legno rivestita interamente in velluto, dettaglio gamba Chippendale.

*Console with wooden frame entirely covered in velvet. Chippendale leg detail.*

**Art.902\_ALTAI**

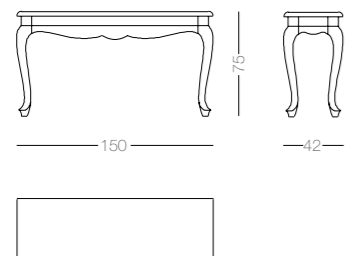

# Doralice



Consolle con struttura in legno rivestita in pelle con cuciture eseguite a mano tono su tono, piano rivestito in Galuchat.

*Console with wooden frame covered in leather with handmade tone-on-tone stitchings, top covered in Galuchat.*

**Art.903\_DORALICE**

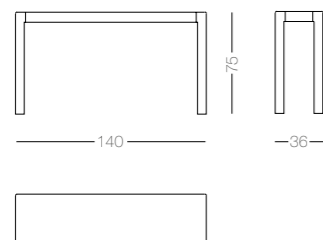

# Oxford



Consolle con struttura in legno rivestita in pelle con dettagli in pelle traforata con decoro brogue, top in marmo nero assoluto, profilo e piedini in ottone bronzato.

*Console with wooden frame covered in leather with details in perforated leather with brogue decoration, top in absolute black marble, profile and feet in bronze-plated brass.*

**Art.905\_OXFORD**

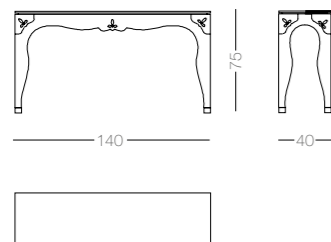

# Loto

Consolle con struttura in legno, piano e spalle rivestiti in velluto, dettagli floreali in pregiata pelle di Capretto impunturata tono su tono.

*Console with wooden frame, top and side panels covered in velvet, floral details in fine Kid leather with tone-on-tone backstitching.*

## Art.906\_LOTO

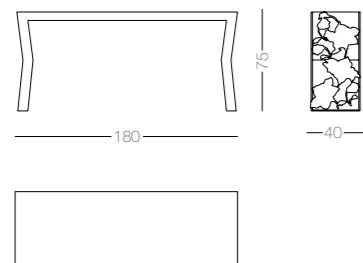

# Stilo

Consolle con struttura in legno interamente rivestita in pelle con cuciture eseguite a mano tono su tono.

*Console with wooden frame entirely covered in leather with handmade tone-on-tone stitchings.*

**Art.907\_STILO**

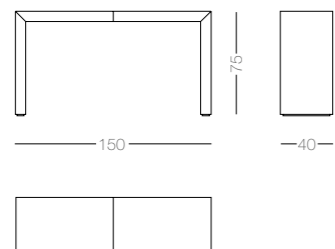

# Dorian



Consolle con struttura in legno rivestita in pelle inserto in ottone bronzato.

*Console with wooden frame covered in leather, insert in bronze-plated brass.*

**Art.908\_DORIAN**

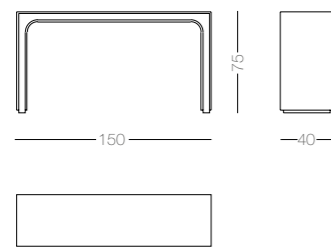

# Intrigo



Consolle con struttura in legno laccato bianco lucido, dettaglio in velluto intrecciato a mano sulle gambe.

*Console with frame in glossy white lacquered wood, detail in hand-interwoven velvet on legs.*

**Art.909\_INTRIGO**

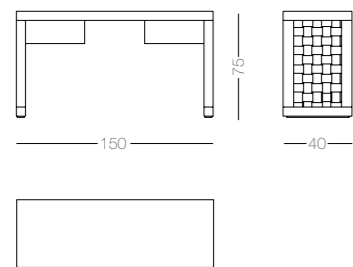



# Eden

Consolle con struttura in legno laccato bianco lucido, decorazione ad intreccio con moduli ad incastro rivestiti in pelle.

*Console with frame in glossy white lacquered wood, interwoven detail with joint system and leather covering.*

**Art.910\_EDEN**

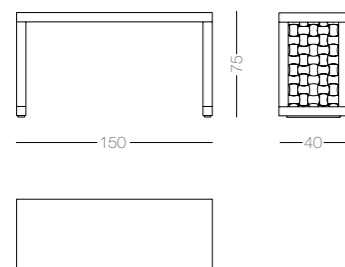

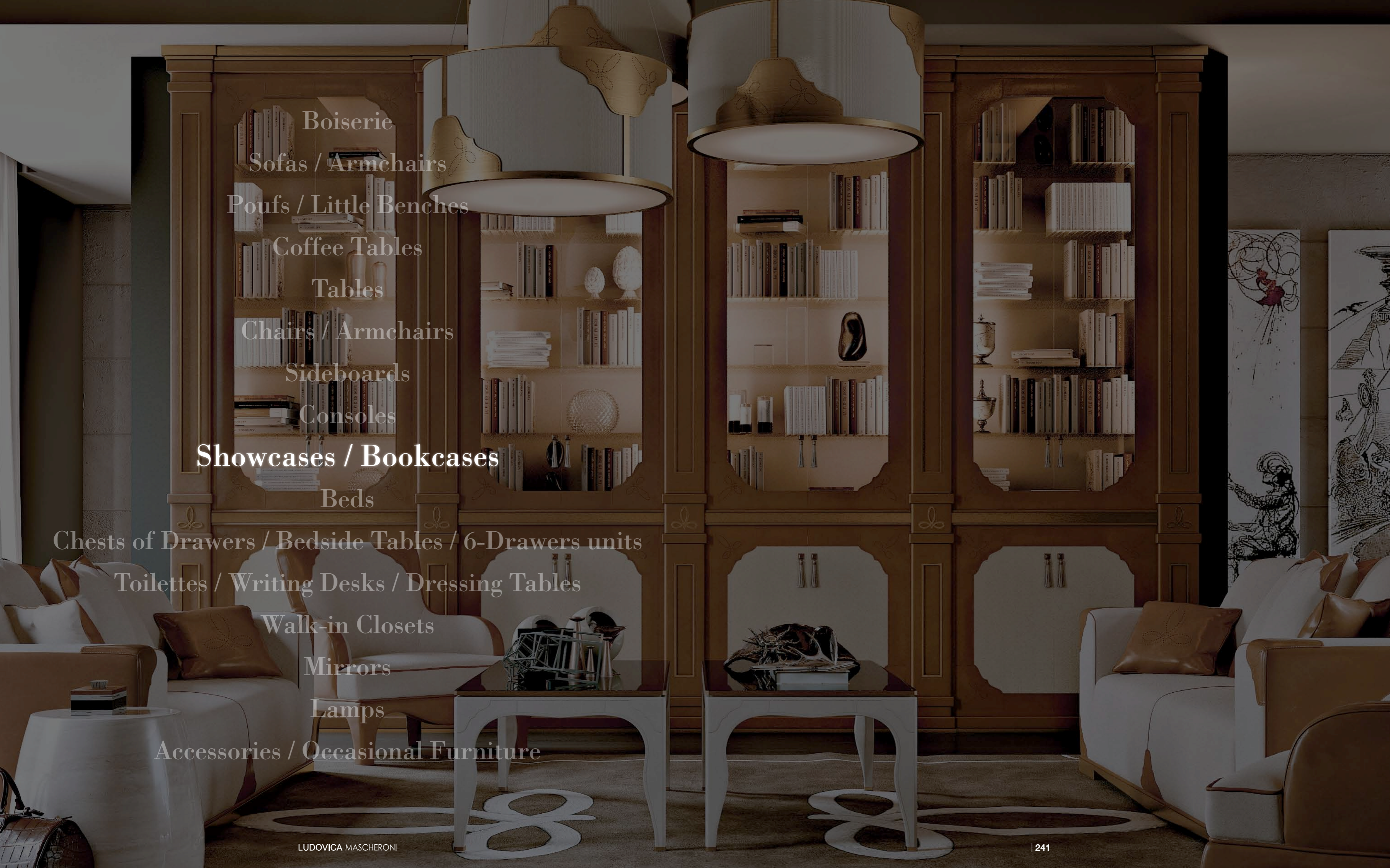

Boiserie

Sofas / Armchairs

Poufs / Little Benches

Coffee Tables

Tables

Chairs / Armchairs

Sideboards

Consoles

**Showcases / Bookcases**

Beds

Chests of Drawers / Bedside Tables / 6-Drawers units

Toilettes / Writing Desks / Dressing Tables

Walk-in Closets

Mirrors

Lamps

Accessories / Occasional Furniture

# Oxford



Vetrina con struttura in legno rivestita in pelle, dettagli in pelle traforata con decoro brogue, ripiani in cristallo, illuminazione interna, base in ottone bronzato.

*Showcase with wooden frame covered in leather, details in perforated leather with brogue decoration, glass shelves, inside lighting, base in bronze-plated brass.*

**Art.1002\_OXFORD**

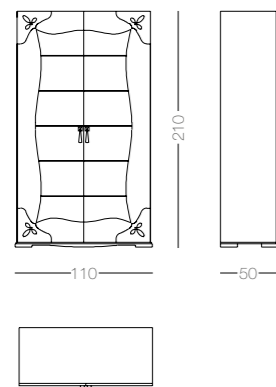

# Oxford

Libreria con struttura in legno rivestita in tessuto con dettagli in pelle traforata con decoro brogue, ripiani in cristallo e base in ottone bronzato.

*Bookcase with wooden frame covered in fabric with details in perforated leather with brogue decoration, glass shelves and base in bronze-plated brass.*

## Art. 1705\_ OXFORD

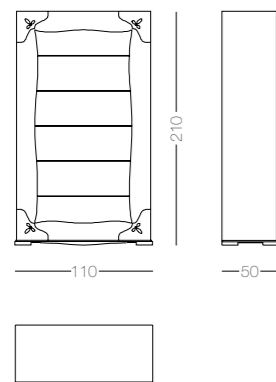

# Dorian



Vetrina con struttura in legno rivestita in pelle, cornice in ottone bronzato, ripiani in legno, ante in cristallo, illuminazione interna e base in ottone bronzato.

*Showcase with wooden frame covered in leather, edging frame in bronze-plated brass, wooden shelves, inside lighting and base in bronze-plated brass.*

Art.1003\_DORIAN

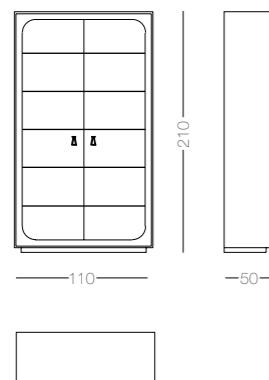

# Dorian

Libreria con struttura in legno rivestita in pelle, cornice in ottone bronzato, ripiani in legno, base in ottone bronzato.

*Bookcase with wooden frame covered in leather, edging frame in bronze-plated brass, wooden shelves, base in bronze-plated brass.*

**Art. 1704\_DORIAN**

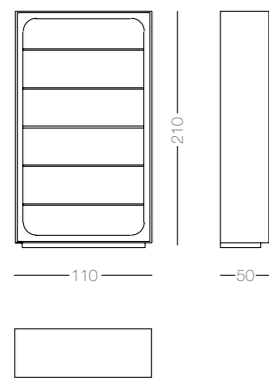

# Serena

Libreria con struttura in legno rivestita in lino 100%.  
*Bookcase with wooden frame covered in 100% Linen.*

**Art.1701/A\_SERENA**

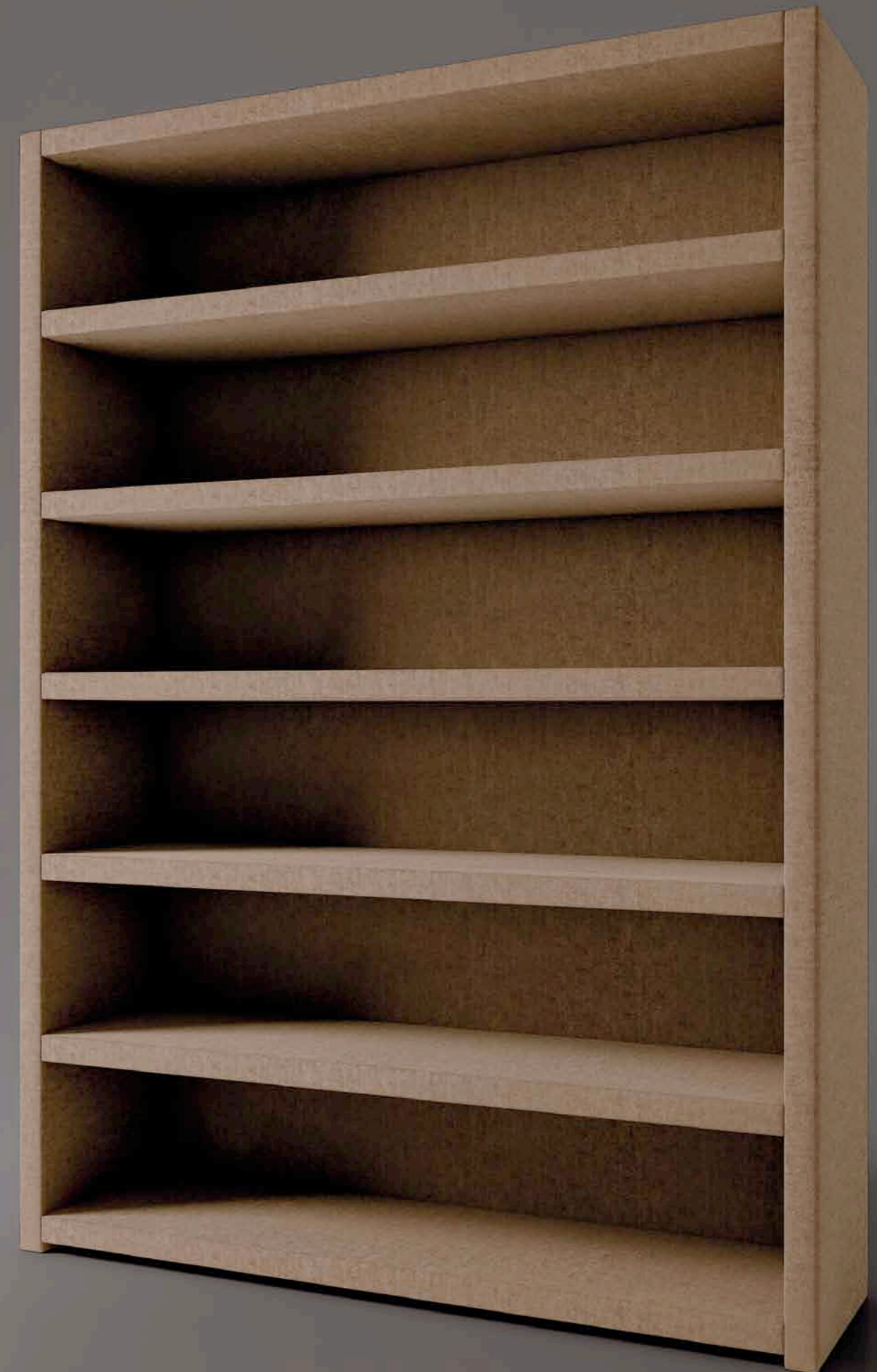
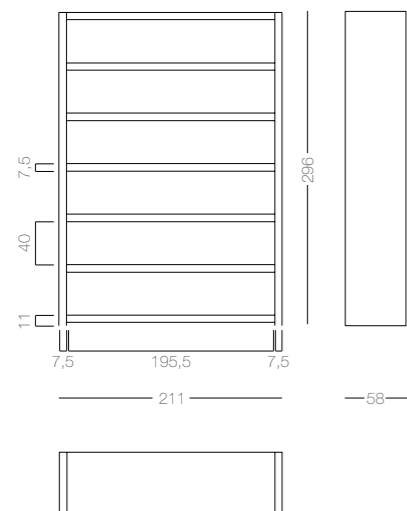

# Serena

Libreria con struttura in legno rivestita in lino 100%.

*Bookcase with wooden frame covered in 100% linen.*

**Art.1701/B\_SERENA**

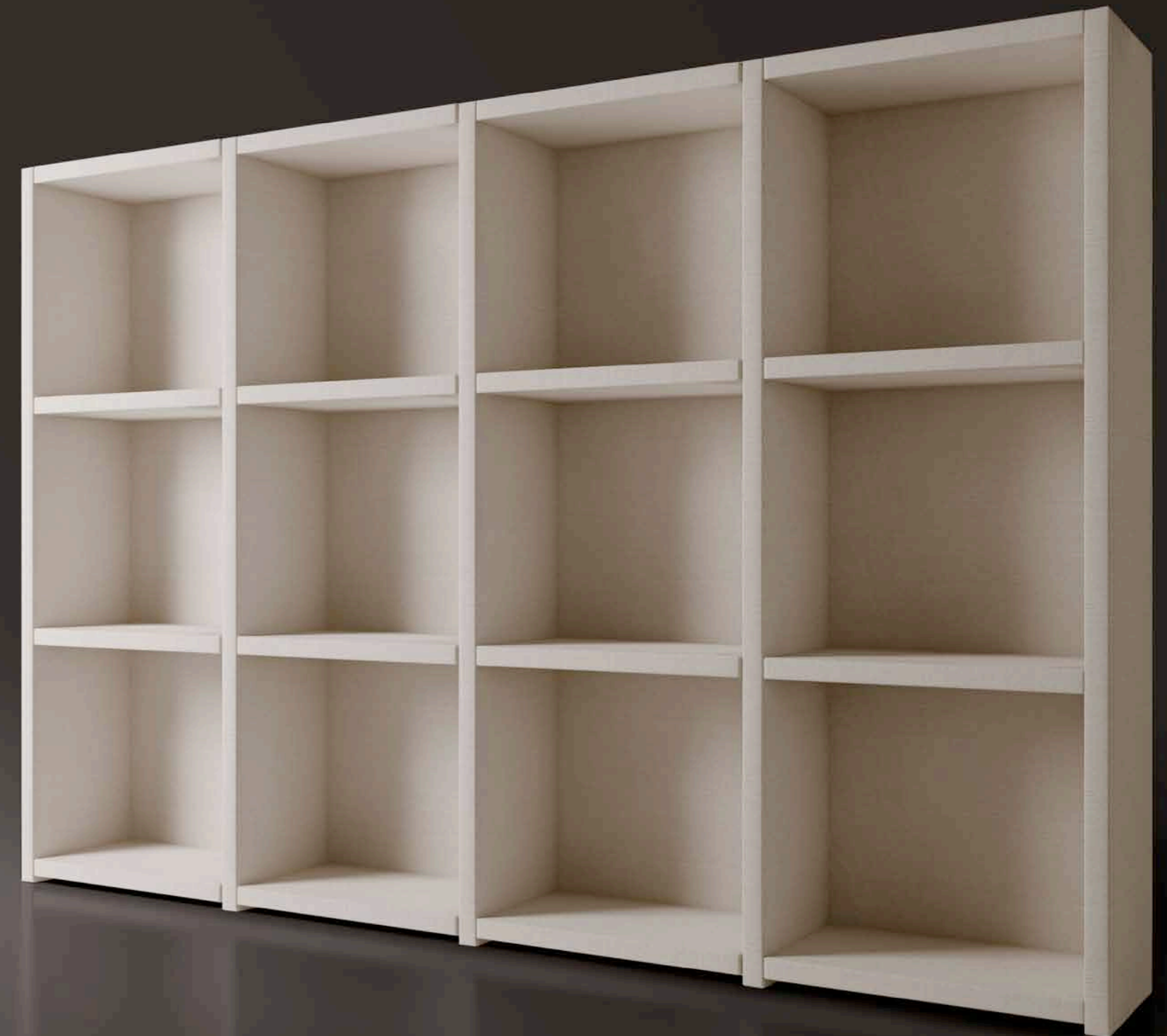
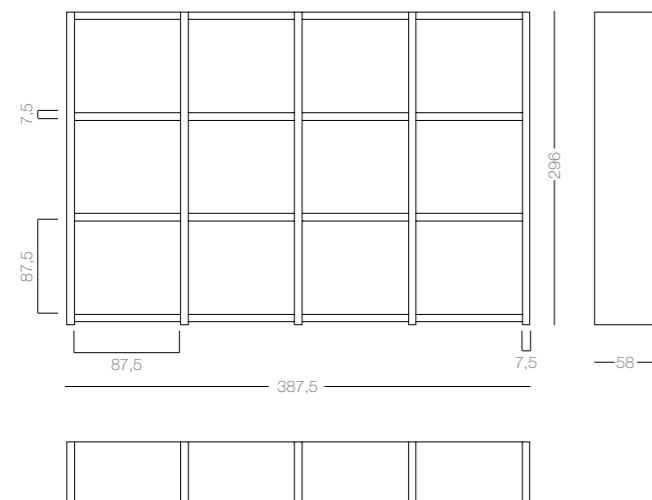



# Diletta



Libreria con struttura in legno essenza Ebano Makassar, spalle e parte inferiore dei ripiani rivestiti in Nubuck con cucitura centrale eseguita a mano, dettagli e basi in ottone bronzato.

*Bookcase with wooden frame in Makassar ebony, sides and under-shelves covered in Nubuck with central handmade stitching, details and bases in bronze-plated brass.*

Art.1702\_DILETTA

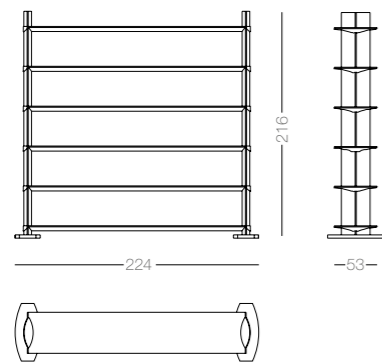

# Oxford



Vetrina con ante e ripiani in cristallo, struttura in legno rivestito in pelle. Dettagli traforati con decoro brogue. Ante inferiori in tessuto e mensole interne in Ebano Makassar. Illuminazione interna a Led, base e profili in ottone bronzato.

*Showcase with glass shelves, wooden frame covered in leather. Perforated details with brogue decoration. Lower doors upholstered in fabric and interior shelves in Makassar Ebony. Internal LED lighting, base and profiles in bronze-plated brass.*

Art.1703\_OXFORD

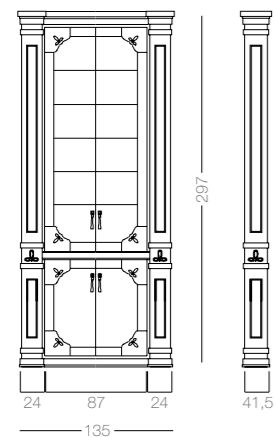

**Boiserie**

Sofas / Armchairs

Poufs / Little Benches

Coffee Tables

Tables

Chairs / Armchairs

Sideboards

Consoles

Showcases / Bookcases

**Beds**

Chests of Drawers / Bedside Tables / 6-Drawers units

Toilettes / Writing Desks / Dressing Tables

Walk-in Closets

Mirrors

Lamps

Accessories / Occasional Furniture

# Prissy

Letto con struttura in legno rivestito in 100% Cashmere, piedini rivestiti in pelle.

*Bed with wooden frame covered in 100% Cashmere, feet covered in leather.*

**Art.1201\_PRISSY**

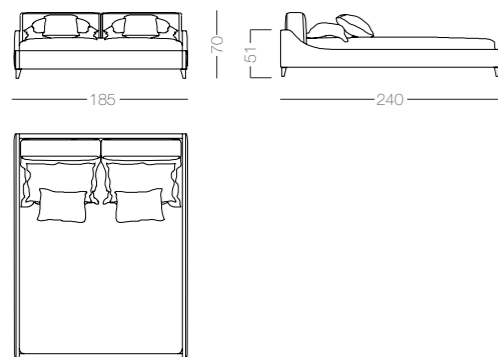

# Altai



Letto con struttura in legno rivestita in Nubuck, testata in velluto o Nubuck con lavorazione capitonné. Decoro floreale intagliato.

*Bed with wooden frame covered in Nubuck, headboard in velvet or Nubuck with button-tufting. Floral carved decoration.*

**Art.1202\_ALTAI**

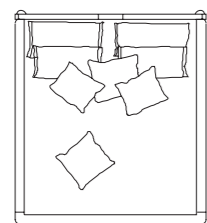
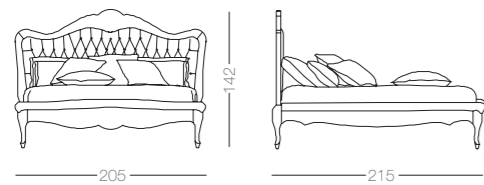

# Intrigo



Letto con struttura in legno, testata e giroletto rivestiti in velluto intrecciato a mano leggermente imbottito.

*Bed with wooden frame, headboard and bedframe covered in lightly padded interwoven velvet.*

## Art.1203\_INTRIGO

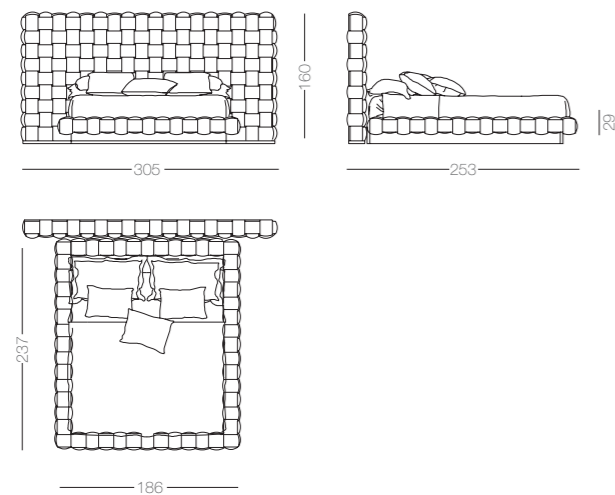

# Eloro



Letto con struttura in legno, rivestito in pelle. Morbida testata avvolgente in seta, basamento in ottone bronzato.

*Bed with wooden frame covered in leather. Soft enveloping headboard in silk, base in bronze-plated brass.*

## Art.1204\_ELORO

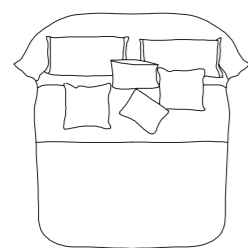
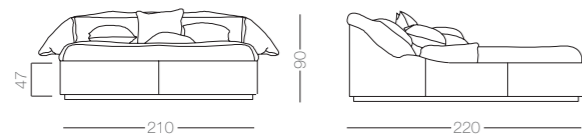

# Edra



Letto con struttura in legno rivestito in pelle, testata imbottita con lavorazione capitonné.

*Bed with wooden frame covered in leather, button-tufted headboard.*

**Art. 1205\_EDRA**

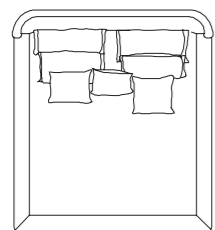
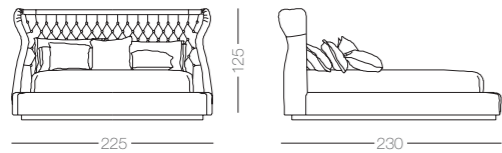



# Eden



Letto con struttura in legno, sistema a intreccio rivestito in pelle, cornice - profilo in ottone bronzato, giroletto rivestito in pelle, piedini in ottone bronzato.

*Bed with wooden frame, interweaving covered in leather, frame - profile in bronze-plated brass, bedframe covered in leather, feet in bronze-plated brass.*

## Art.1206\_EDEN

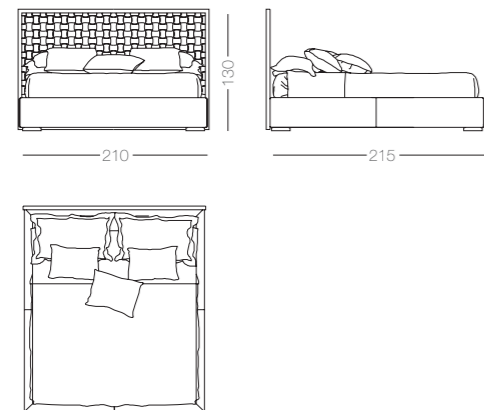

# Grace

Letto con struttura in legno, testata imbottita con lavorazione capitonné rivestita in velluto, cornice rivestita in 100% Cashmere, giroletto rivestito in pelle, basamento in ottone bronzato.

*Bed with wooden frame, headboard with button-tufting covered in velvet, frame covered in 100% Cashmere, bed frame covered in leather, base in bronze-plated brass.*

## Art. 1207 \_ GRACE

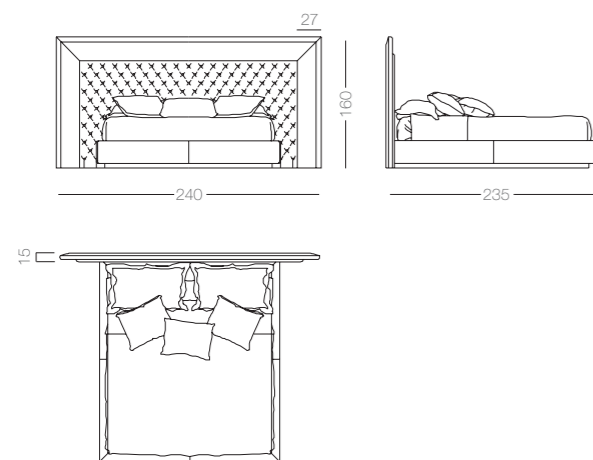

# Oxford



Letto con struttura in legno, rivestito in cotone misto lino con dettagli in pelle traforata con decoro brogue, basamento in ottone bronzato.

*Bed with wooden frame, covered in cotton linen, details in perforated leather with brogue decoration, base in bronze-plated brass.*

## Art.1208\_OXFORD

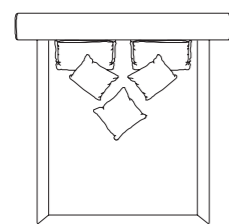
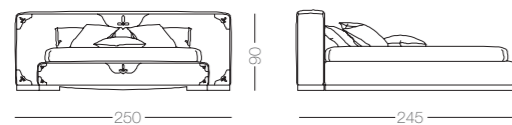

# Skyline

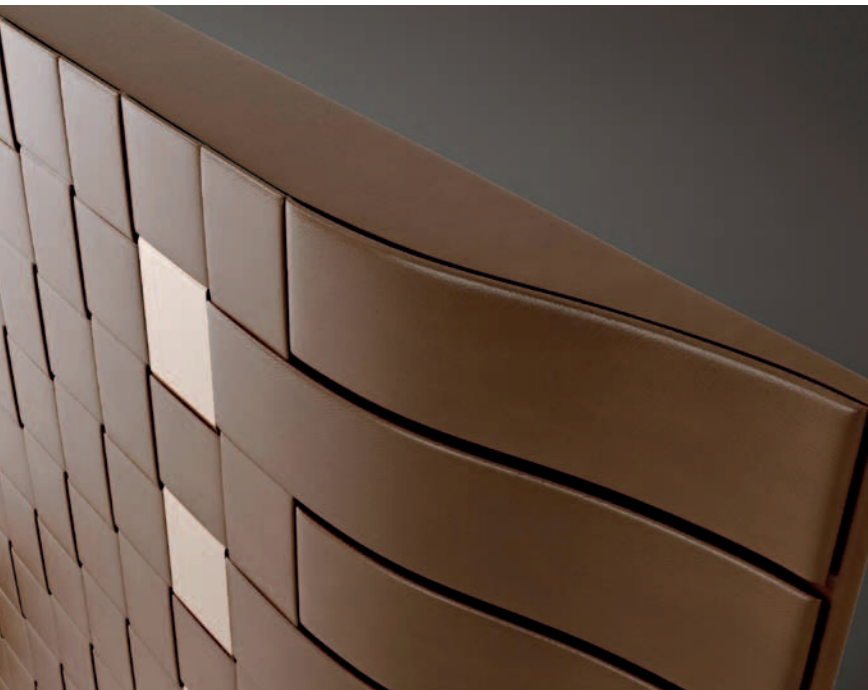

Letto con struttura in legno rivestita in pelle, testata con sistema a intreccio rivestito in pelle e ottone bronzato, illuminazione a Led. Comodini in legno rivestiti in pelle, interno cassetti in microfibra con cuciture eseguite a mano tono su tono ed essenza Sucupira. Basamento in ottone bronzato.

*Bed with wooden frame upholstered in leather, headboard with interwoven system covered in leather and bronze-plated brass, LED lighting. Wooden bedside tables covered in leather, interior of drawers covered in micro-fibre with handmade tone-on-tone stitching and Sucupira wood. Base in bronze-plated brass.*

## Art.1209\_SKYLINE

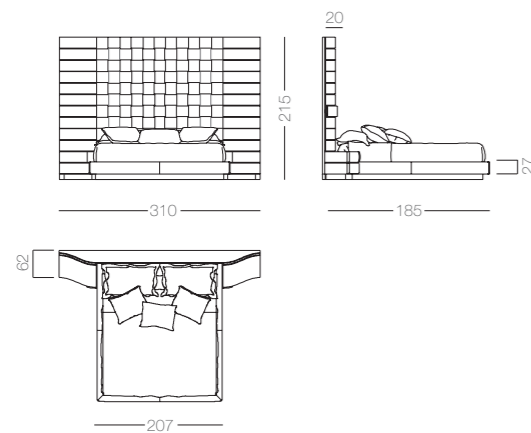

# Oxford Club



Letto con struttura in legno e testata attrezzata. Rivestimento in pelle e velluto. Dettagli in pelle traforata con decoro brogue, basamento in essenza Sucupira.

*Bed with wooden frame and equipped headboard. Cover in leather and velvet. Details in perforated openwork leather with brogue decoration, base and shelves in Sucupira wood.*

## Art.1210\_OXFORD CLUB

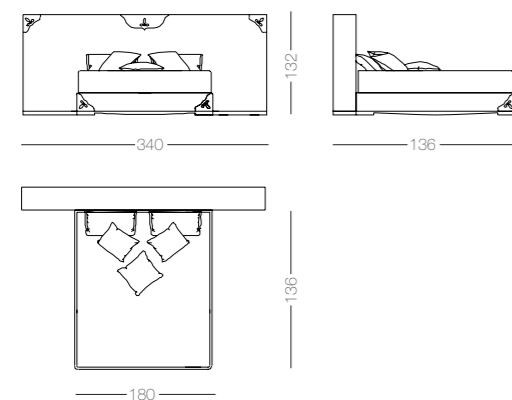

# Oxford Club

Retro testata letto con vani a giorno, spalle e schienale in legno essenza Sucupira e ripiani rivestiti in pelle.

*Back headboard with open compartments, back panels and sides in Sucupira wood and shelves covered in leather.*

## Art.1210\_OXFORD CLUB

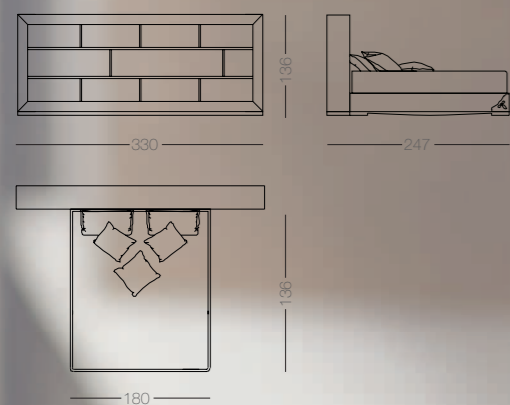

Boiserie

Sofas / Armchairs

Poufs / Little Benches

Coffee Tables

Tables

Chairs / Armchairs

Sideboards

Consoles

Showcases / Bookcases

Beds

**Chests of Drawers / Bedside Tables / 6-Drawers unit**

Toilettes / Writing Desks / Dressing Tables

Walk-in Closets

Mirrors

Lamps

Accessories / Occasional Furniture

# Erasmus



Comò con struttura in legno rivestito in Baby Cashmere, piano in pregiata pelle di Coccodrillo, interno dei cassetti rivestiti in microfibra con cuciture eseguite a mano tono su tono.

*Chest of drawers with wooden frame covered in Baby Cashmere, top in fine Crocodile, interior of drawers covered in microfibre with handmade tone-on-tone stitching.*



Art.1101\_ERASMO

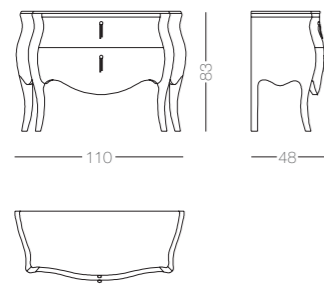



# Erasmus 150



Comò con struttura in legno rivestito in pelle, cassetti rivestiti in velluto, interno dei cassetti in microfibra con cuciture eseguite a mano tono su tono.

*Chest of drawers with wooden frame covered in leather, drawers covered in velvet, interior of drawers covered in microfibre with handmade tone-on-tone stitchings.*

Art.1102\_ERASMO 150

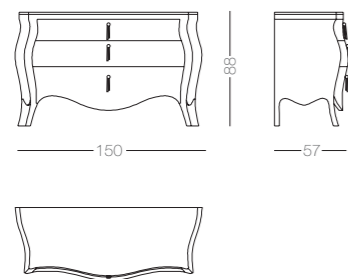

# Erasmus

Comodino con struttura in legno rivestito in Nubuk, interno cassetti in microfibra con cuciture eseguite a mano tono su tono.

*Bedside table with wooden frame, covered in Nubuk, drawers lined in microfibra with tone-on-tone stitching carried out by hand.*

**Art. 1311\_ERASMO**

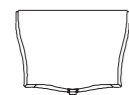
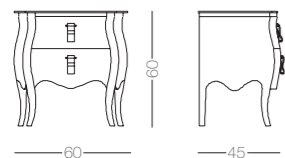

# Prissy



Comò con struttura in legno rivestito in tessuto e cassetti in pelle, interni in microfibra con cuciture tono su tono.

*Chest of drawers with wooden frame covered in fabric and drawers in leather, drawer inside in microfibre with tone-on-tone stitchings.*

**Art.1103\_PRISSY**

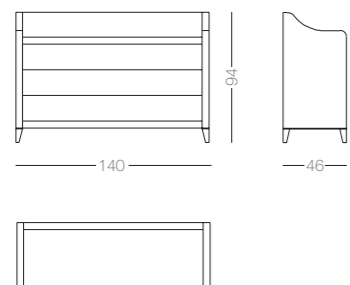

# Prissy

Comodino con struttura in legno rivestito in tessuto e cassetti in pelle, interni in microfibra con cuciture eseguite a mano tono su tono.

*Bedside table with wooden frame covered in fabric, drawers in leather, inside in microfibre with handmade tone-on-tone stitchings.*

## Art. 1301\_PRISSY

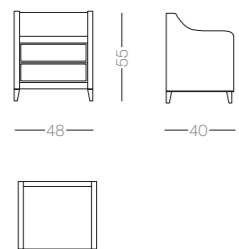

# Prissy

Settimanale con struttura in legno rivestito in pelle, interni dei cassetti rivestiti in microfibra con cuciture eseguite a mano tono su tono.

*6-drawer unit with wooden frame covered in leather, drawer inside covered in microfibre with handmade tone-on-tone stitchings.*

## Art. 1401\_PRISSY

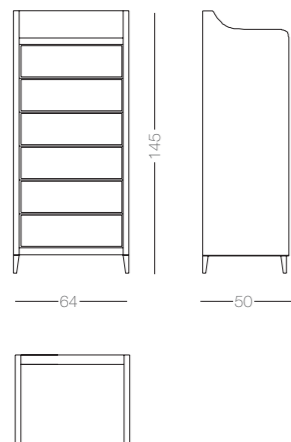

# Eloro



Comò con struttura in legno rivestito in velluto, interno dei cassetti in microfibra con cuciture eseguite a mano tono su tono, basamento in ottone bronzato.

*Chest of drawers with wooden frame covered in velvet, drawer inside in microfibre with handmade tone-on-tone stitchings, base in bronze-plated brass.*

Art.1104\_ELORO

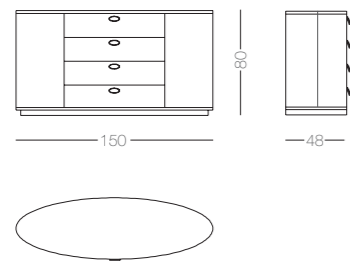

# Eloro



Comodino con struttura in legno rivestito in pelle con cuciture eseguite a mano tono su tono, interno cassetto in microfibra, basamento in ottone bronzato.

*Bedside table with wooden frame covered in leather with handmade tone-on-tone stitchings, drawer inside in microfibre, base in bronze-plated brass.*



**Art.1303\_ELORO**

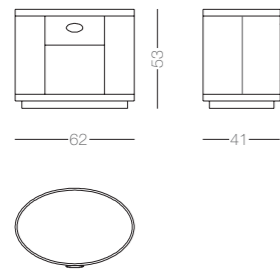

# Eloro

Settimanale con struttura in legno rivestito in pelle con cuciture eseguite a mano tono su tono, interno dei cassetti in microfibra e basamento in ottone bronzato.

*6-drawer unit with wooden frame covered in leather, handmade tone-on-tone stitchings, drawer inside in microfibre and base in bronze-plated brass.*

## Art. 1402\_ELORO

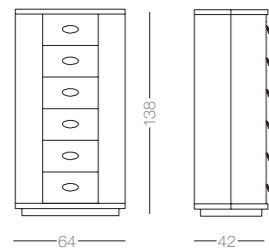



# Dorian



Comò con struttura in legno rivestito in pelle. Cassetti rivestiti in tessuto con sistema di apertura "Push and Pull". Cornice e basamento in ottone bronzato.

*Chest of drawers with wooden frame covered in leather. Drawers covered in fabric and Push & Pull opening system. Frame and base in bronze-plated brass.*

**Art.1106\_DORIAN**

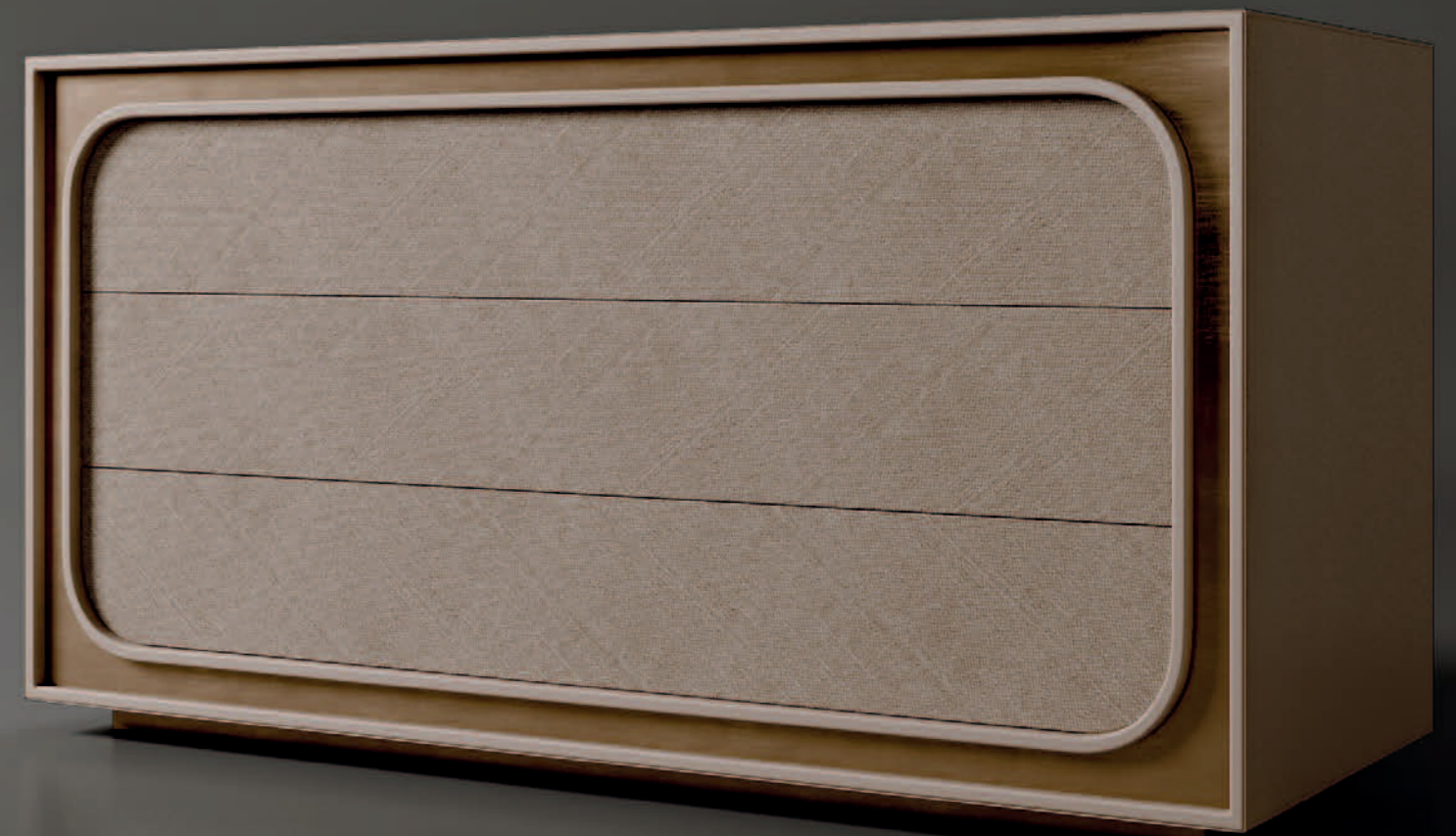
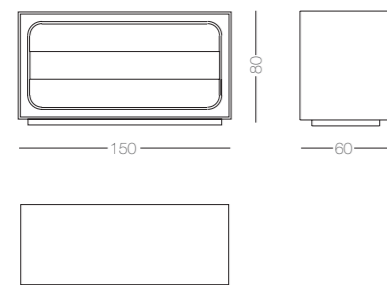

# Dorian

Comodino con struttura in legno rivestito in pelle. Cassetti rivestiti in pelle con sistema di apertura "Push and Pull". Cornice e basamento in ottone bronzato.

*Bedside table with wooden frame covered in 100% Cashmere, drawer with interwoven decoration and joint modules covered in leather, frame and base in bronze-plated brass.*

## Art. 1309\_DORIAN

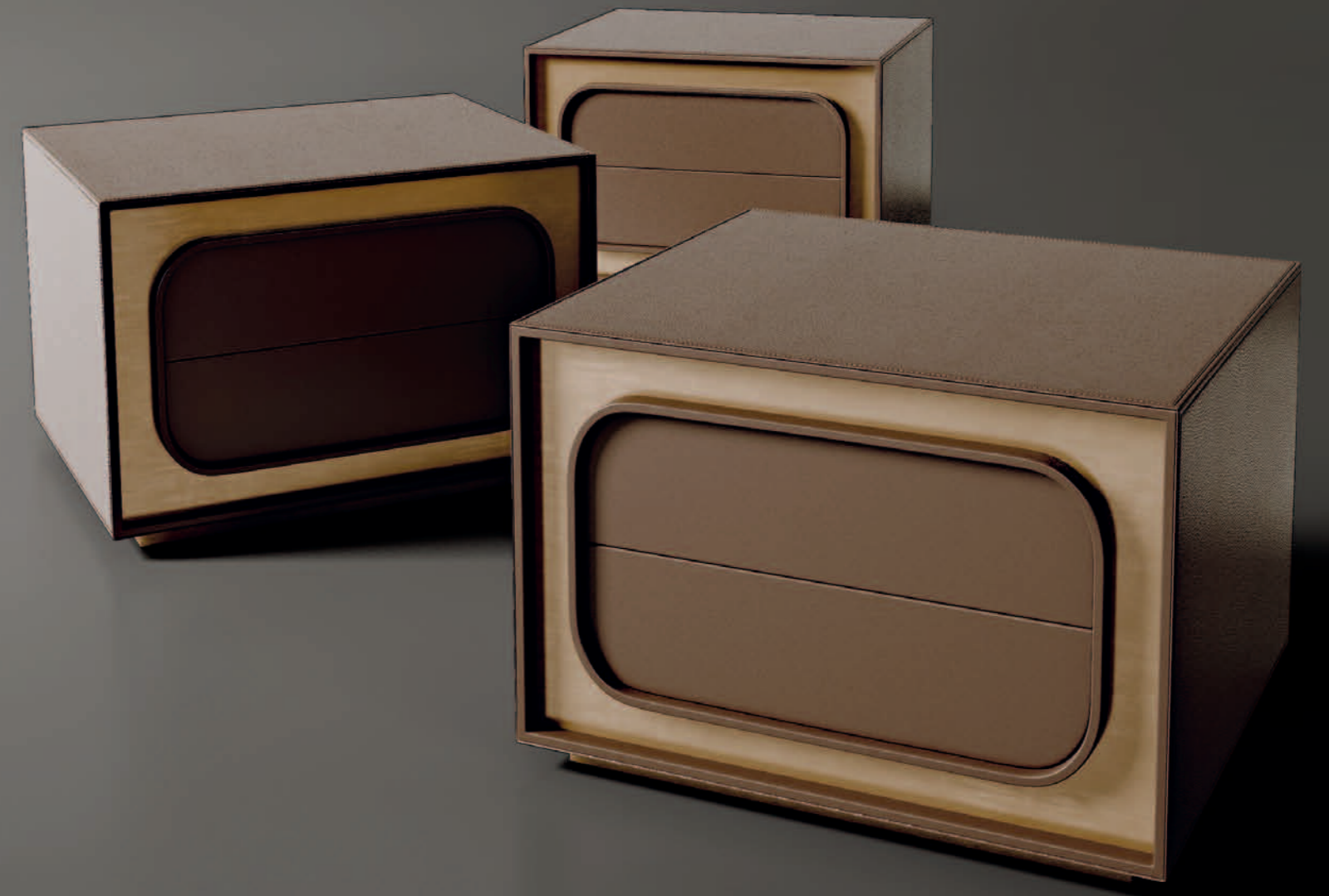
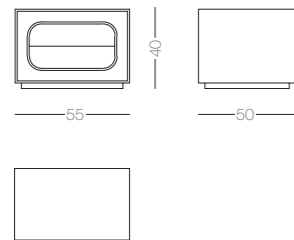

# Dorian

Settimanale con struttura in legno rivestito in pelle. Cassetti rivestiti in tessuto con sistema di apertura "Push and Pull". Cornice e basamento in ottone bronzato.

*6-drawer unit with wooden frame covered in 100% Cashmere, drawer with interwoven decoration and joint modules covered in leather, frame and base in bronze-plated brass.*

## Art. 1403\_DORIAN

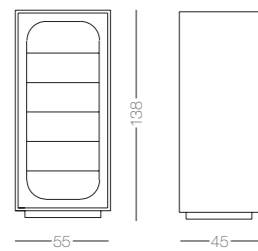

# Eden

Comò con struttura in legno rivestito interamente in Nubuk e interno cassetti in microfibra. Cornice in ottone bronzato, apertura cassetti con sistema "Push and Pull".

*Chest of drawers with wooden structure, covered entirely in Nubuk and drawers lined in microfibre. Frame in bronze-plated brass with push-and-pull drawer opening.*

**Art.1111\_EDEN**

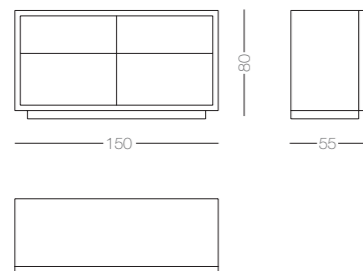

# Eden



Comodino con struttura in legno rivestito in 100% Cashmere, cassetto con decorazione ad intreccio con moduli ad incastro rivestiti in pelle. Cornice e basamento in ottone bronzato.

*Bedside table with wooden frame covered in 100% Cashmere, drawer with interwoven leather decoration and joint modules covered in leather. Frame and base in bronze-plated brass.*

Art.1304\_EDEN

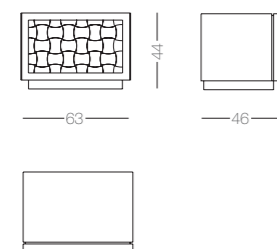

# Eden

Settimanale con struttura in legno rivestito interamente in Nubuk e interno cassetti in microfibra. Cornice frontale in ottone bronzato, apertura cassetti con sistema "Push and Pull".

*6-drawer unit with wooden frame, covered entirely in Nubuk with drawers lined in microfibre. Front edging framed in bronze-plated brass with push-and-pull drawer opening.*

## Art. 1405\_EDEN

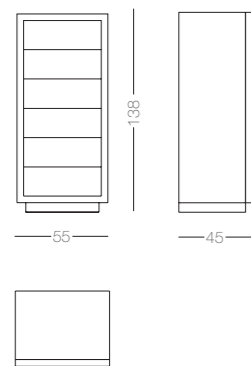

# Eden



Comò con struttura in legno laccato bianco lucido, spalle con decorazione ad intreccio con moduli ad incastro rivestiti in velluto leggermente imbottiti.

*Chest of drawers with frame in glossy white lacquered wood, side panels with interwoven decoration with joint modules in lightly padded velvet.*

Art.1107\_EDEN

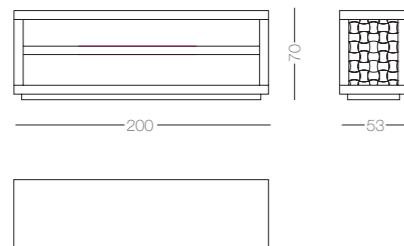

# Intrigo



Comò con struttura in legno laccato bianco lucido, spalle rivestite in velluto intrecciato a mano, apertura cassetti push and pull.

*Chest of drawers with frame in glossy white lacquered wood, side panels covered in hand-interwoven velvet, push-pull drawer opening.*

**Art.1108\_INTRIGO**

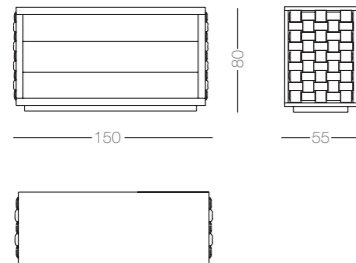



# Intrigo



Comodino con struttura in legno laccato bianco lucido, cassetto rivestito in velluto intrecciato a mano leggermente imbottito.

*Bedside table with glossy white lacquered wooden frame, drawer covered in interwoven velvet, carried out by hand and lightly padded.*

**Art.1308\_INTRIGO**

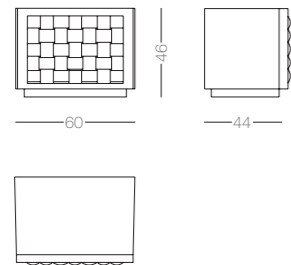

# Intrigo



Comò con struttura in legno laccato bianco lucido, spalle rivestite in velluto intrecciato a mano leggermente imbottito.

*Chest of drawers with frame in glossy white lacquered wood, side panels in interwoven velvet, carried out by hand and lightly padded.*

Art.1107\_INTRIGO

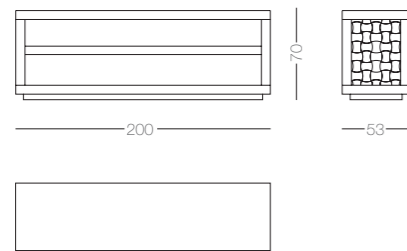

# Edra

Comò con struttura in legno rivestito in pelle con cuciture eseguite a mano tono su tono, top in marmo Crema Delicato, interno dei cassetti in microfibra. Basamento in ottone bronzato.

*Chest of drawers with wooden frame covered in leather with tone-on-tone stitching, carried out by hand. Top in Crema Delicato marble, interior of drawers in micro-fibre. Base in bronze-plated brass.*

## Art. 1109\_EDRA

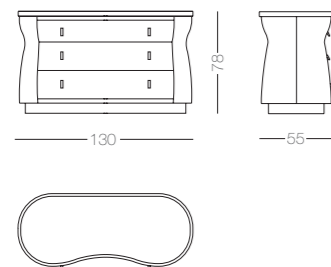

# Edra



Comodino con struttura in legno rivestito in pelle con cuciture eseguite a mano tono su tono, top in marmo Crema Delicato, interno cassetti in microfibra. Basamento in ottone bronzato.

*Bedside table with wooden frame covered in leather with handmade tone-on-tone stitchings, top in Crema Delicato marble, interior of drawers in micro-fibre. Base in bronze-plated brass.*

**Art. 1305\_EDRA**

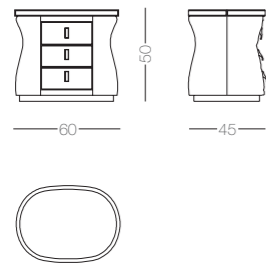

# Skyline

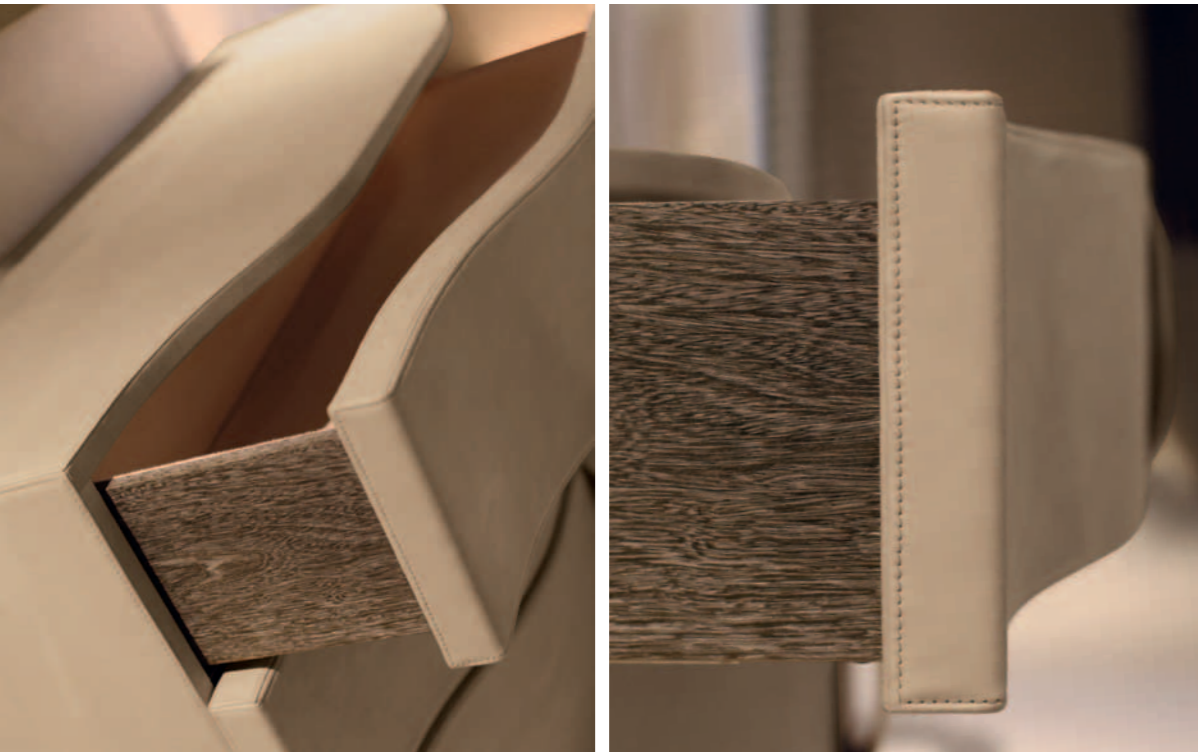

Comò con struttura in legno curvato, interamente rivestito in pelle con leggera imbottitura. Cuciture eseguite a mano tono su tono. Interno in microfibra ed essenza Sucupira. Basamento in ottone bronzato.

*Chest of drawers with curved wooden frame, entirely covered in leather with light padding. Handmade tone-on-tone stitching. Interior in micro-fibre with Sucupira wood. Base in bronze-plated brass.*

**Art.1110\_SKYLINE**

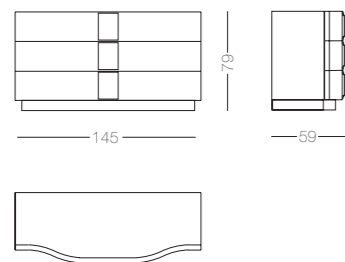

# Oxford

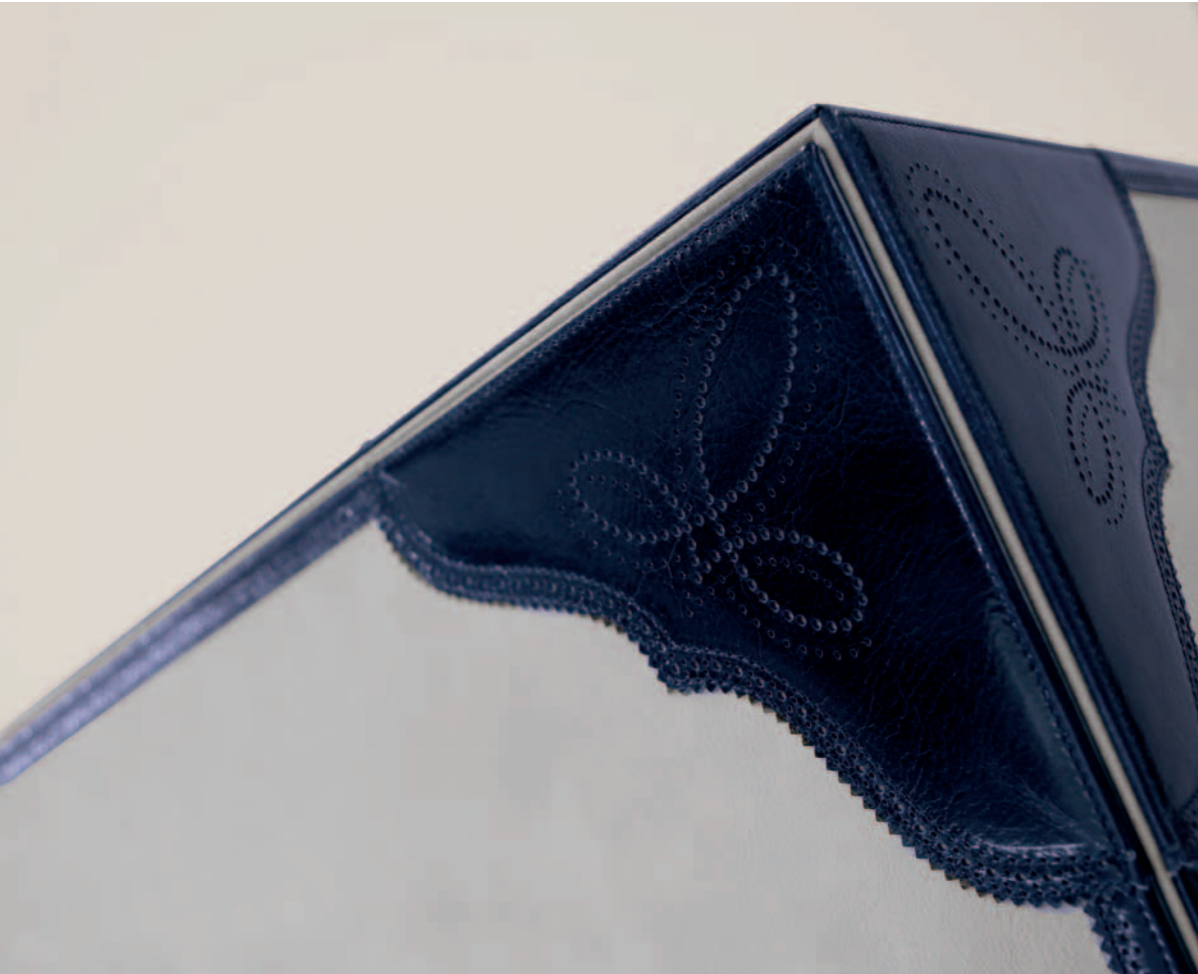

Comò a tre cassetti con struttura in legno rivestita in pelle, dettagli in pelle traforata con decoro brogue, cuciture a mano tono su tono. interno cassetti in lino e pelle. Basamento in ottone bronzato; disponibile anche nella versione in legno essenza sucupira.

*Three-drawer dresser with wooden frame covered in leather, details in perforated leather with brogue decoration and tone-on-tone hand stitching. Interior of drawers in linen and leather. Base in bronze-plated brass, also available in the version in Sucupira wood.*

Art.1112\_OXFORD

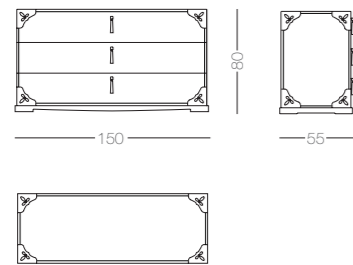

# Oxford



Comodino con struttura in legno rivestita in pelle, dettagli in pelle traforata con decoro brogue, cuciture a mano tono su tono. Interno cassetti in lino e pelle. Basamento in ottone bronzato; disponibile anche nella versione in legno essenza Sucupira.

*Bedside table with wooden structure covered in leather, details in perforated leather with brogue decoration and tone-on-tone handmade stitching. Interior of drawers in linen and leather. Base in bronze-plated brass – also available in the version with Sucupira wood.*

**Art.1310/A\_OXFORD**

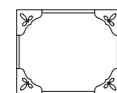
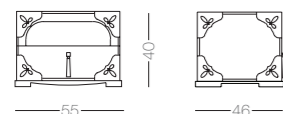

**Art.1310/B\_OXFORD**

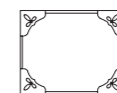
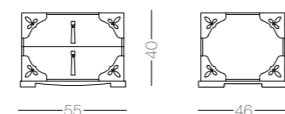

**Art.1310/C\_OXFORD**

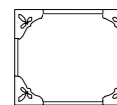
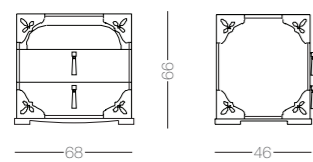

# Oxford



Settimanale con struttura in legno rivestito in cotone misto lino con dettagli in pelle traforata con decoro brogue. Interno cassetti in lino e pelle con cuciture a mano tono su tono. Basamento in ottone bronzato; disponibile anche nella versione in legno essenza Sucupira.

*6-drawer unit with wooden frame covered in cotton-linen, details in perforated leather with brogue decoration and tone-on-tone handmade stitching. Interior of drawers in linen and leather. Base in bronze-plated brass – also available in the version with Sucupira wood.*

**Art.1404\_OXFORD**

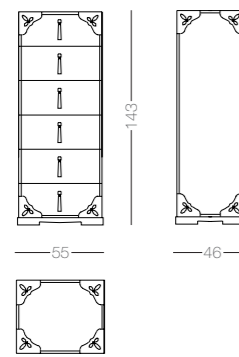

**Art.1404\_OXFORD XL**

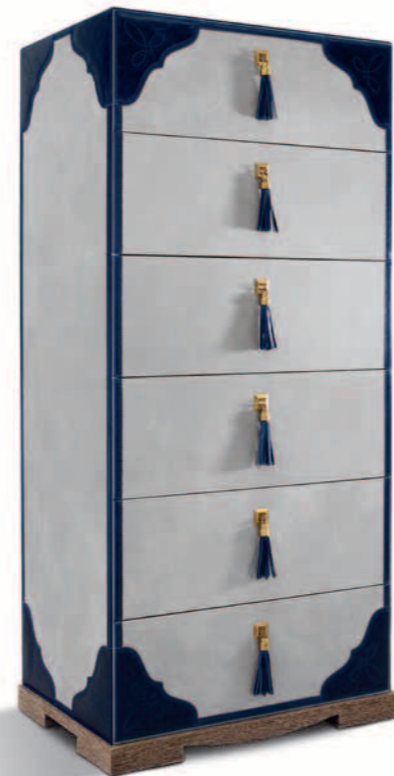
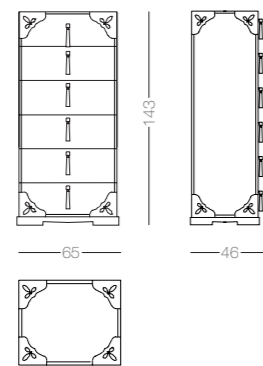



# Altai



Comodino con struttura in legno e cassetto rivestiti in 100% Cashmere, dettaglio gamba Chippendale.

*Bedside table with wooden frame and drawer covered in 100% Cashmere, Chippendale leg detail.*

**Art.1302\_ALTAI**

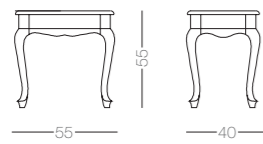

Boiseries

Sofas / Armchairs

Poufs / Little Benches

Coffee Tables

Tables

Chairs / Armchairs

Sideboards

Consoles

Showcases / Bookcases

Beds

Chests of Drawers / Bedside Tables / 6-Drawers units

**Toilettes / Writing Desks / Dressing Tables**

Walk-in Closets

Mirrors

Lamps

Accessories / Occasional Furniture

# Manhattan



Mobile bar con struttura in legno rivestito in pelle con fascia centrale in preziosa pelle di cocodrillo. Interno in essenza Ebano Amara, specchi bronzati, illuminazione led con sensore di apertura e frigo bar. Maniglia e dettagli in ottone bronzato.

*Cocktail cabinet, frame covered in leather and central strip in fine crocodile leather. Interior in Amara Ebony, bronze-finished mirrors, LED lighting with opening sensors and minibar fridge. Handle and details in bronze-plated brass.*



Art.1004\_MANHATTAN

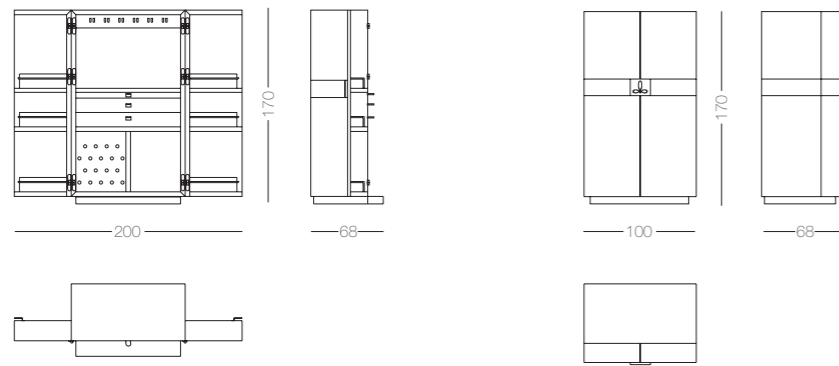

# Jackie



Baule trucco con struttura in legno rivestita esternamente in pelle e internamente in Nubuck. Dettagli: lavorazione ricamata, vani e cassetti porta oggetti, led dimerabile, vetro "stop sol" con monitor integrato, appendi abiti e particolari verniciati in finitura oro.

*Beauty chest with wooden frame, outer covering in leather and interior in Nubuck. Details: embroidered workmanship, shelves and drawers, dimmable LED, "stop sol" glass with integrated monitor, clothes hangers and details painted in gold finish.*

Art.1005\_JACKIE

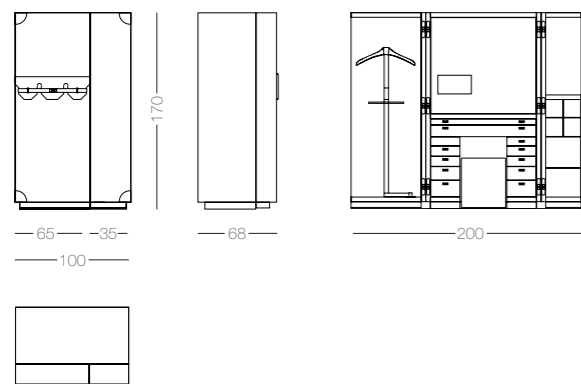

# Torquato



Scrittoio con struttura in legno rivestito in velluto di seta, interno cassetti in pelle, cuciture eseguite a mano tono su tono, dettaglio gamba Chippendale.

*Writing desk with wooden frame covered in silk velvet, drawer inside in leather, handmade tone-on-tone stitchings, Chippendale leg detail.*

**Art.1501\_TORQUATO**

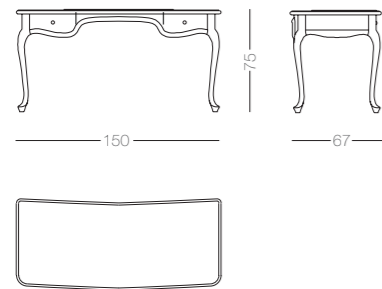

# Venere



Toilette con struttura in legno rivestita in pelle, fianchi impunturati, cassetti con interni in microfibra, cuciture eseguite a mano tono su tono e ribaltina con specchio.

*Dressing table with wooden frame covered in leather, backstitched sides, drawer inside in microfibre, handmade tone-on-tone stitchings, hinged flap panel with mirror.*



Art.1502\_VENERE

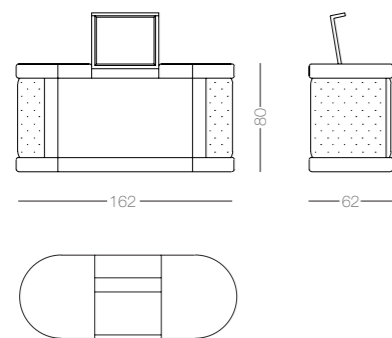

# Xeno



Scrivania con struttura in ottone bronzato. Top rivestito in cuoio o pelle.  
Cassetti frontali con interni in pelle.

*Desk with frame in bronze-plated brass. Top in leather or thick leather.  
Front drawers with leather interiors.*

**Art. 1503\_XENO**

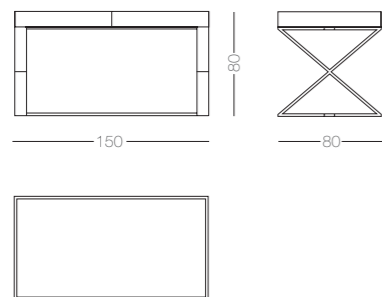

# Stilo



Scrivania e cassetiera con struttura in legno rivestita in pelle, cuciture eseguite a mano tono su tono.

*Writing desk and drawer unit with wooden frames covered in leather, handmade tone-on-tone stitchings.*

**Art.1504\_STILO**

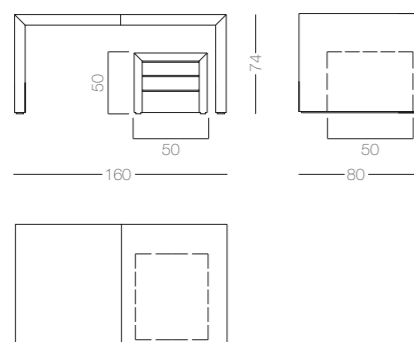



# Chelsea



Scrivania con struttura in legno rivestita interamente in pelle. Dettagli traforati con decoro brogue. Piedini in ottone bronzato.

*Writing desk with wooden frame entirely covered in leather. Details in perforated leather with brogue decoration. Feet in bronze-plated brass.*

**Art.1505\_CHELSEA**

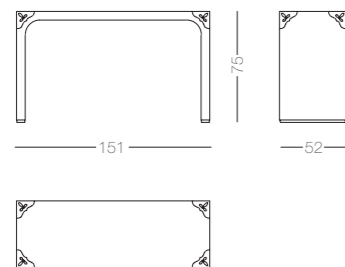

# Oxford



Scrivania con struttura in legno rivestita in pelle. Dettagli traforati con decoro brogue. Pannello in plexiglass opalino bianco retro illuminato da luce led, basamento e passa cavi in ottone bronzato.

*Writing desk with wooden frame covered in leather. Details in perforated leather with brogue decoration. LED backlit opaline white plexiglas panel, base and grommet in bronze-plated brass.*

## Art.1506\_OXFORD

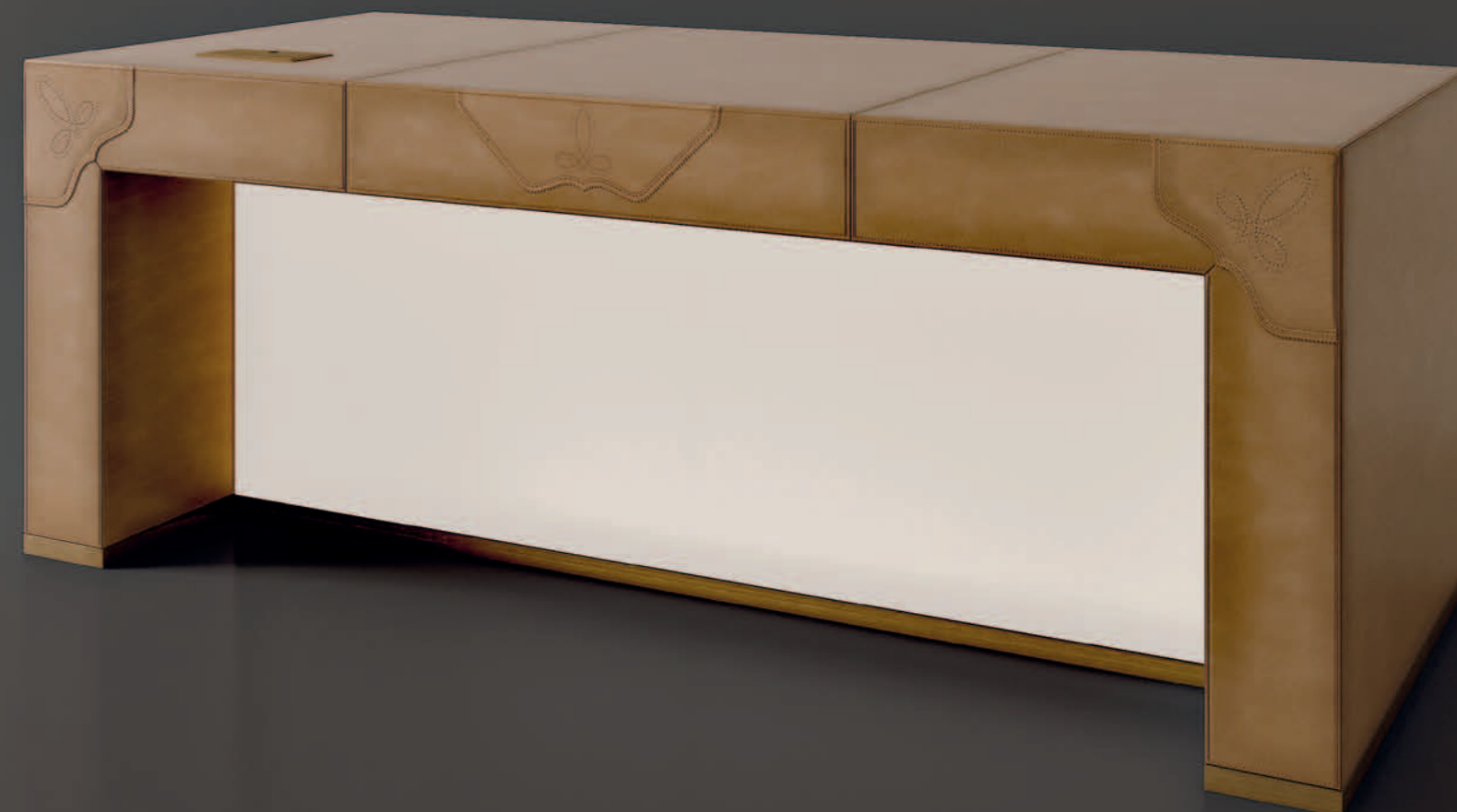
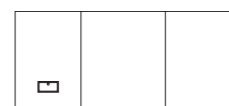
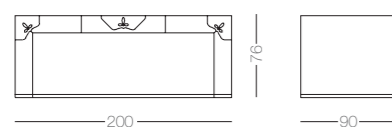



Boiserie

Sofas / Armchairs

Poufs / Little Benches

Coffee Tables

Tables

Chairs / Armchairs

Sideboards

Consoles

Showcases / Bookcases

Beds

Chests of Drawers / Bedside Tables / 6-Drawers units

Toilettes / Writing Desks / Dressing Tables

**Walk-in Closets**

Mirrors

Lamps

Accessories / Occasional Furniture

# Alice



Cabina armadio rivestita interamente in cashmere 100%. Interni dei cassetti in microfibra con cuciture eseguite a mano tono su tono. Maniglie rivestite in pelle. Attrezzata con ripiani regolabili in altezza su cremagliere, barre appenderia, cassettiere e ripiani reggiscarpe.

*Walk-in closet upholstered entirely in 100% cashmere. Interior of drawers in micro-fibre with tone-on-tone stitching, carried out by hand. Handles covered in leather. Equipped with adjustable shelves on racks, hanging rods, drawers and shelves and racks for shoes.*

## Art.1601\_ALICE



# Ariel



Cabina armadio rivestita interamente in cashmere 100%. Interni dei cassetti in microfibra con cuciture eseguite a mano tono su tono. Maniglie rivestite in pelle. Attrezzata con ripiani regolabili in altezza su cremagliere, barre appenderia, cassettiere e ripiani reggiscarpe.

*Walk-in closet entirely covered in 100% cashmere. Drawer inside in microfibre with handmade stitchings. Handles covered in leather. Equipped with adjustable shelves on racks, hanging rods, drawers and racks for shoes.*

## Art.1602\_ARIEL

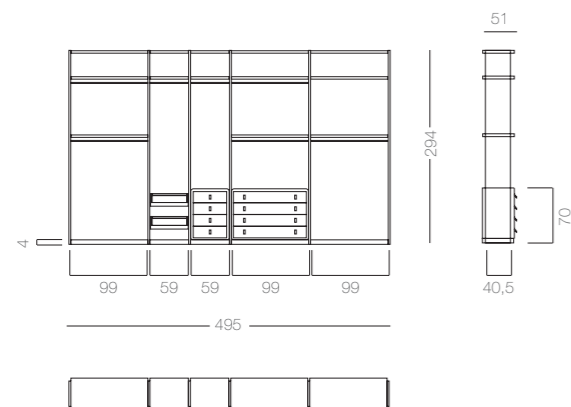

# Arluna



Cabina armadio con struttura in legno rivestita in pelle, sistema ad intreccio interamente eseguito a mano in pelle ed ottone bronzato. Struttura interna rivestita in cashmere 100%, illuminazione verticale a Led, schienali rivestiti in tessuto pregiato. Frontali cassetti rivestiti in pelle con leggera imbottitura e interno in microfibra con cuciture eseguite a mano tono su tono. Piedini in ottone bronzato. Attrezzata con ripiani regolabili in altezza su cremagliere e barre appendieria.

*Walk-in closet with wooden frame covered in leather, interweaving entirely handmade in leather and bronze-plated brass. Inside structure covered in 100% Cashmere, vertical LED lighting, back panels covered in fine fabric. Front drawers covered in leather with light padding and interior in microfibre with handmade tone-on-tone stitching. Feet in bronze-plated brass. Equipped with adjustable shelves on racks and hanging rods.*

## Art.1603\_ ARLUNA

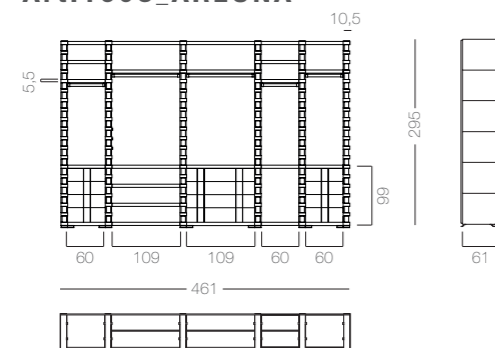

# Oxford Club



Cabina armadio completamente rivestita in Nubuck e cuoio naturale tamponato a mano. Schienali: pannelli con illuminazione led uniforme sulla superficie, rivestiti in tessuto. Dettagli traforati con decoro "brogue" e interno cassetti in pelle e lino naturale. Accessori: strisce led sotto ripiani, "servetto" ed estrazione colonne per accessori motorizzati, ripiani porta scarpe in vetro extrachiaro e dettagli ottone bronzato.

*Walk-in closet completely covered in Nubuck and natural thick leather with hand-padded finish. Back panels: panels with LED lighting, uniform on the surface, covered with fabric. Perforated details with "brogue" decorations and interior of drawers in leather and natural linen. Accessories: LED strips under the shelves, "Clothes lift" and pull-out columns for motorized accessories, shelves for shoes in extra-clear glass and bronze-plated brass details.*

Art.1604\_ OXFORD CLUB

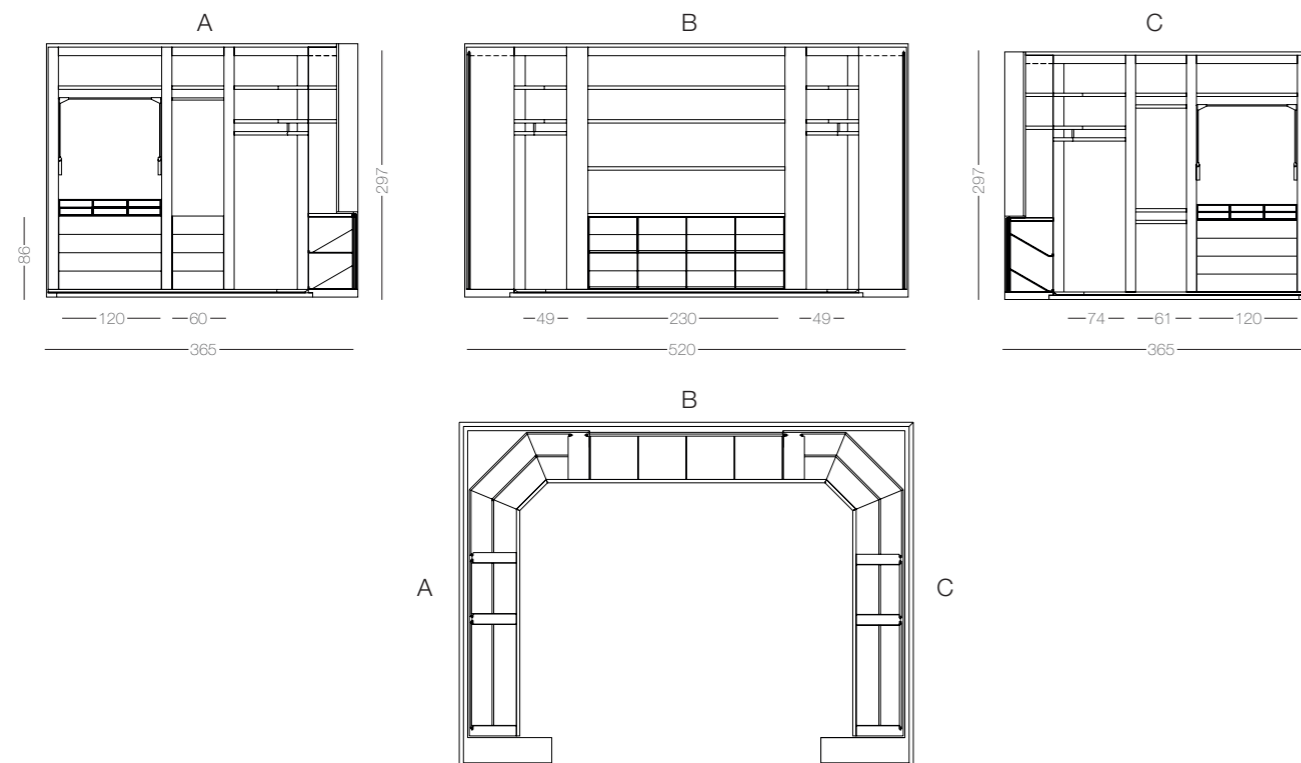









Boiserie

Sofas / Armchairs

Poufs / Little Benches

Coffee Tables

Tables

Chairs / Armchairs

Sideboards

Consoles

Showcases / Bookcases

Beds

Chests of Drawers / Bedside Tables / 6-Drawers units

Toilettes / Writing Desks / Dressing Tables

Walk-in Closets

Mirrors

Lamps

Accessories / Occasional Furniture



# Grace



Specchiera con cornice in legno rivestita in velluto.

*Mirror with wooden frame covered in velvet.*

**Art.1801\_GRACE**

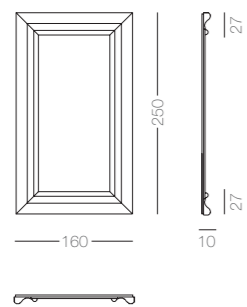

# Intrigo



Specchiera con cornice in legno rivestita in velluto imbottito intrecciato a mano.

*Mirror with wooden frame covered in padded velvet, interwoven by hand.*

Art.1802\_INTRIGO

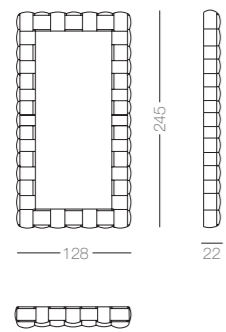

# Ninfea



Specchiera con struttura in legno rivestita in pelle e tessuto leggermente imbottiti. Specchio bisellato.

*Mirror with wooden frame covered in leather and lightly padded fabric. Bevelled mirror.*

**Art.1803\_NINFEA**

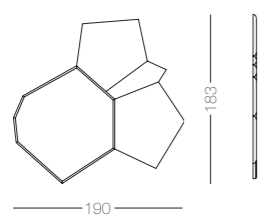

# Alias

Specchiera con cornice in legno rivestita in velluto, specchio bifacciale basculante.

*Mirror with wooden frame covered in velvet and two-sided tilting mirror.*

**Art. 1805\_ALIAS**

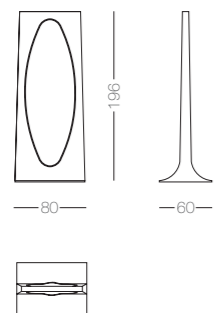

# Oxford



Specchiera con cornice in legno rivestita in pelle, dettagli in pelle traforata con decoro brogue e cuciture a mano tono su tono.

*Mirror with wooden frame covered in leather, perforated leather details with brogue decorations and hand-made tone-on-tone stitching.*

Art.1806\_OXFORD

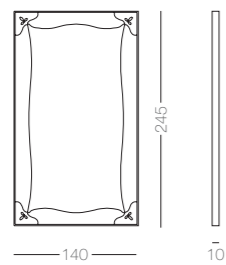

# Dorian



Specchiera con cornice in legno rivestita in pelle, profilo in ottone bronzato.

*Mirror with wooden frame covered in leather, profile in bronze-plated brass*

**Art.1807/A\_DORIAN**

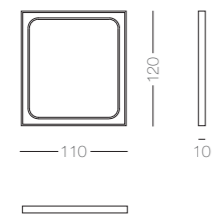

**Art.1807/B\_DORIAN**

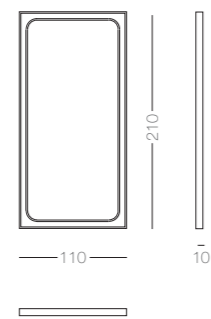



# Eden



Specchiera con cornice in legno, sistema ad intreccio con moduli ad incastro rivestiti in velluto. Profili in ottone bronzato.

*Mirror with wooden frame, interwoven system with joint modules covered in velvet. Profiles in bronze-plated brass.*

**Art.1809\_EDEN**

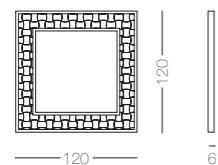

# Chelsea

Specchiera con cornice in legno, interamente rivestita in pelle traforata con decoro brogue.

*Mirror with wooden frame entirely covered in perforated leather with brogue decoration.*

**Art. 1810\_CHELSEA**

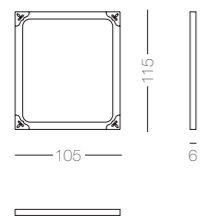

# Skyline



Specchiera con cornice in legno, rivestita in Nubuck e cuciture tono su tono, dettaglio in ottone bronzato.

*Mirror with wooden frame covered in Nubuck and tone-on-tone stitchings, detail in bronze-plated brass.*

**Art.1811\_SKYLINE**

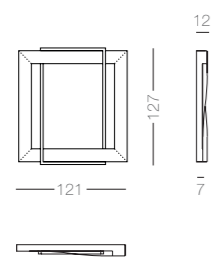

Boiserie

Sofas / Armchairs

Poufs / Little Benches

Coffee Tables

Tables

Chairs / Armchairs

Sideboards

Consoles

Showcases / Bookcases

Beds

Chests of Drawers / Bedside Tables / 6-Drawers units

Toilettes / Writing Desks / Dressing Tables

Walk-in Closets

Mirrors

**Lamps**

Accessories / Occasional Furniture

# Amery

Lampada da terra interamente rivestita in Nubuck selezionato pieno fiore.

*Floor lamp entirely covered in selected full grain Nubuck.*

**Art.2101\_AMERY**

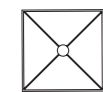
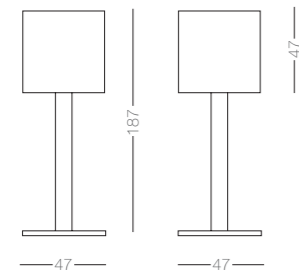

# Tricot



Lampada a soffitto con struttura in ottone bronzato, intreccio in pelle eseguito a mano, plexiglass opalino bianco.

*Ceiling lamp with frame in bronzed brass, interweaving in handmade leather, opaline white plexiglass.*



**Art.2103/A  
TRICOT**

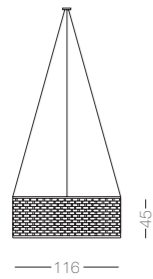

**Art.2103/B  
TRICOT**

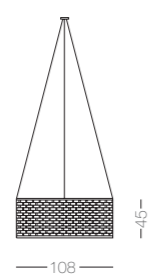

**Art.2103/C  
TRICOT**

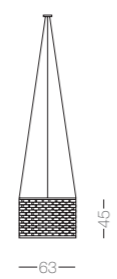

# Tricot



Lampada abat-jour con struttura in ottone bronzato, intreccio in pelle eseguito a mano.

*Lamp with lampshade with frame in bronze-plated brass, interweaving in handmade leather.*

Art.2104\_TRICOT ABAT-JOUR

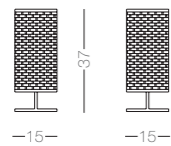

# Tricot

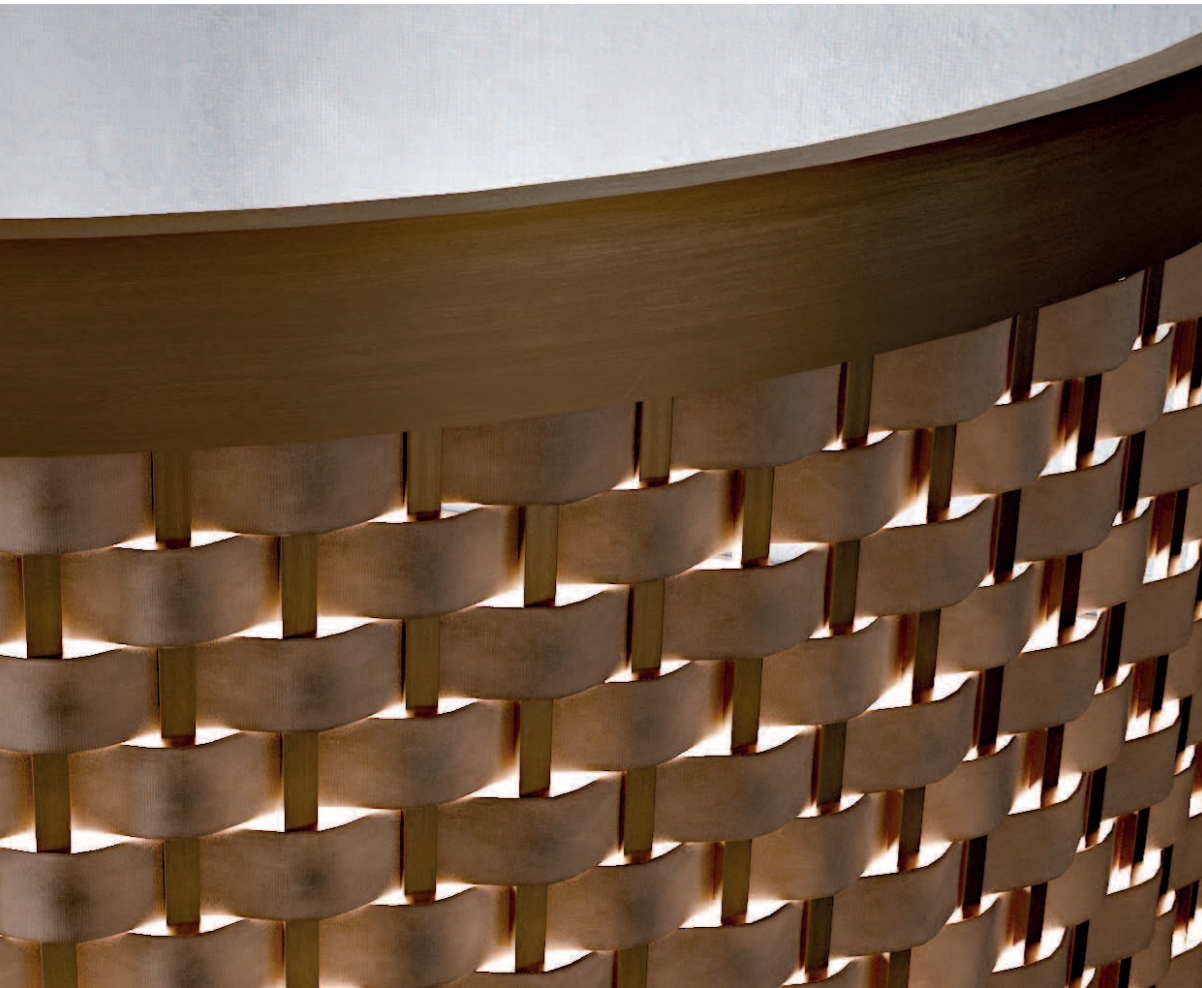

Applique con struttura in ottone bronzato, intreccio in pelle eseguito a mano.

*Wall lamp with frame in bronze-plated brass, interweaving in handmade leather.*

Art.2105\_TRICOT APPLIQUE

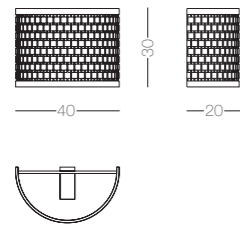



# Tricot

Lampada a soffitto con struttura in ottone bronzato, intreccio in pelle eseguito a mano, plexiglass opalino bianco.

*Ceiling lamp with frame in bronze-plated brass, interweaving in handmade leather, white opaline plexiglass.*

**Art.2108\_TRICOT**

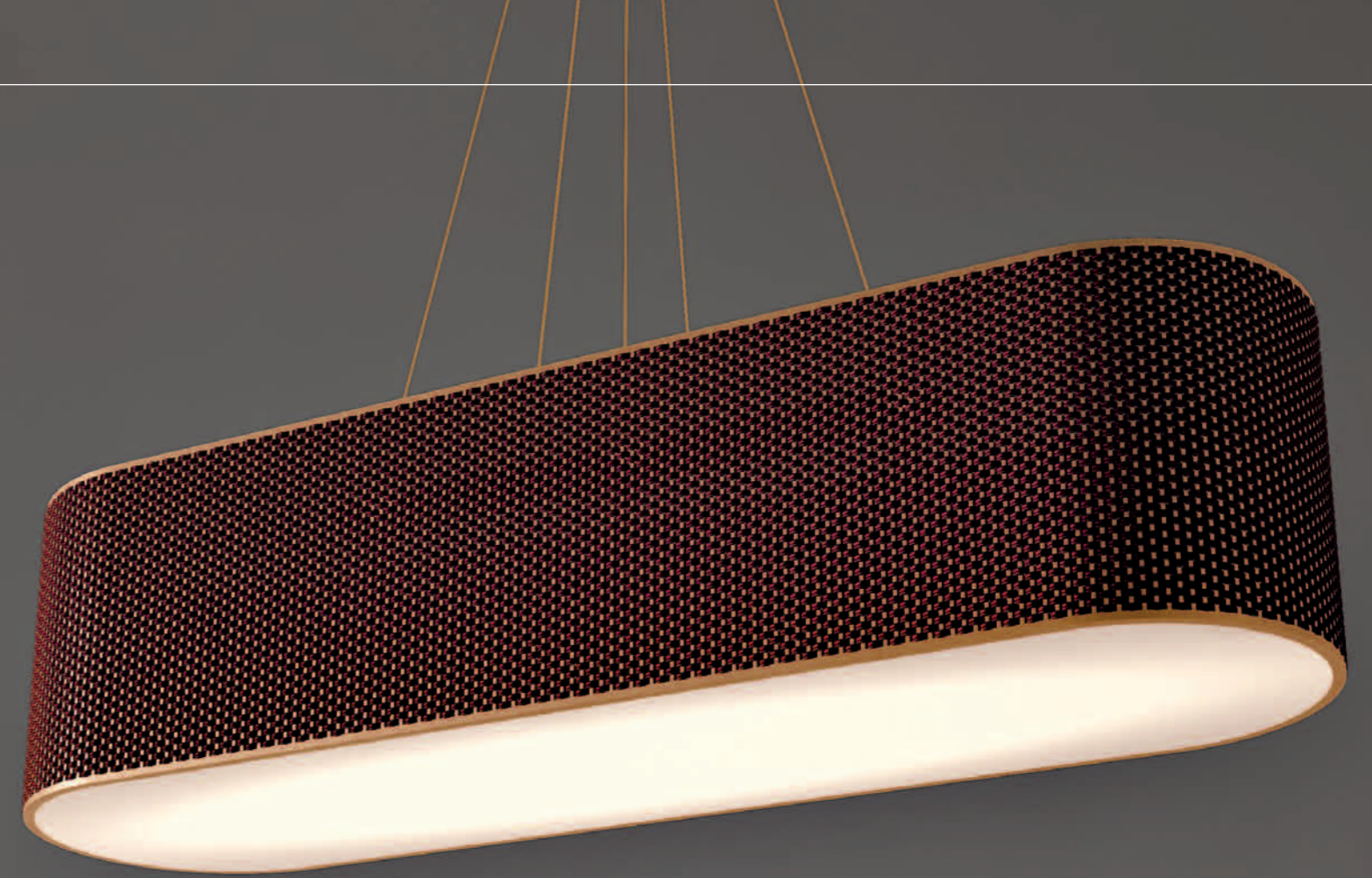
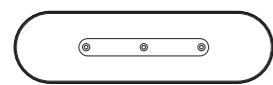
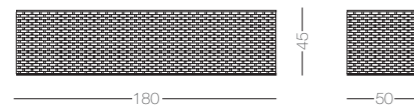

# Tricot

Lampada da terra con struttura in ottone bronzato, intreccio in pelle eseguito a mano.

*Floor lamp with frame in bronze-plated brass, interweaving in handmade leather.*

**Art.2109\_TRICOT**

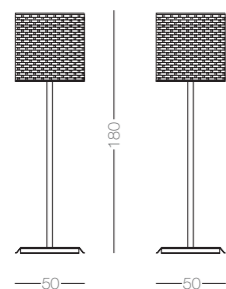

# Oxford



Lampada da tavolo con struttura in ottone bronzato, paralume con dettagli traforati con decoro brogue, plexiglass opalino bianco.

*Table lamp with frame in bronze-plated brass, lampshade with perforated details and brogue decoration and white opaline plexiglas.*

Art.2106\_OXFORD

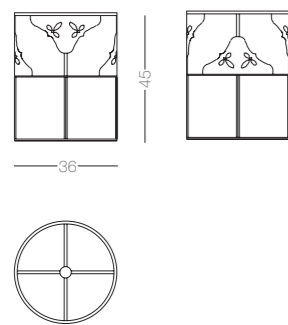

# Oxford



Lampada a soffitto con struttura in ottone bronzato, paralume con dettagli traforati con decoro brogue, plexiglass opalino bianco.

*Ceiling lamp with frame in bronze-plated brass, lampshade with perforated details and brogue decoration, white opaline plexiglass.*



**Art.2107/A  
OXFORD**

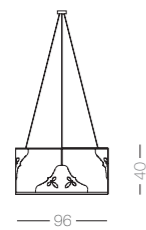

**Art.2107/B  
OXFORD**

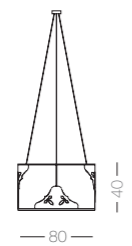

**Art.2107/C  
OXFORD**

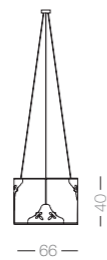

# Oxford

Applique con struttura in ottone bronzato e paralume con dettagli traforati con decoro brogue.

*Wall lamp with bronze-plated frame and lampshade with perforated details and brogue decoration.*

## Art.2110\_ OXFORD APPLIQUE

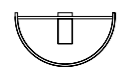

**Boiserie**

**Sofas / Armchairs**

**Poufs / Little Benches**

**Coffee Tables**

**Tables**

**Chairs / Armchairs**

**Sideboards**

**Consoles**

**Showcases / Bookcases**

**Beds**

**Chests of Drawers / Bedside Tables / 6-Drawers units**

**Toilettes / Writing Desks / Dressing Tables**

**Walk-in Closets**

**Mirrors**

**Lamps**

**Accessories / Occasional Furniture**



# Sebastian

Vassoio dalle linee essenziali con struttura in legno, rivestito interamente in pelle, dettagli in ottone.

*Tray with essential lines and wooden frame, covered entirely in leather and with brass details.*

**Art.2001\_SEBASTIAN**

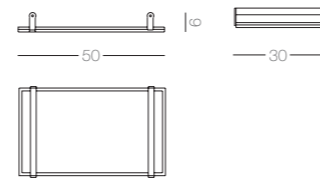

# Oxford

Vassoio con struttura in legno, rivestito in tessuto con dettagli traforati in pelle con decoro brogue negli angoli.

*Tray with wooden frame, covered in fabric, with details in perforated leather and brogue decoration on the corners.*

**Art.2003\_OXFORD**

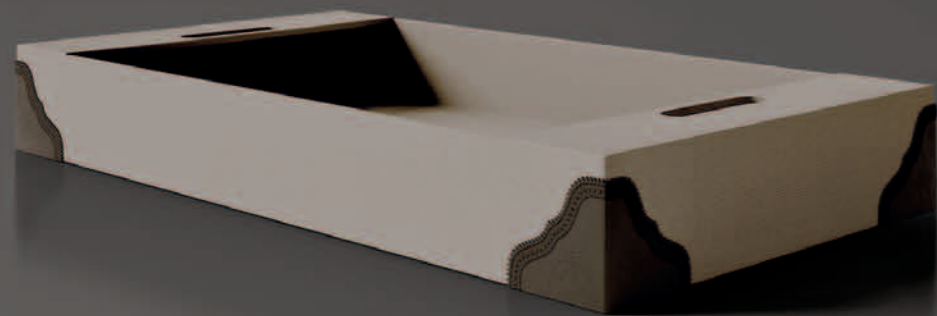
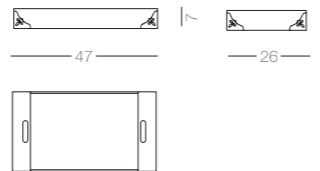

# Chelsea

Vassoio con struttura in legno, rivestito in tessuto, con dettagli traforati in pelle con decoro brogue negli angoli.

*Tray with wooden frame, covered in fabric, with details in perforated leather and brogue decoration on the corners.*

**Art.2005\_CHELSEA**

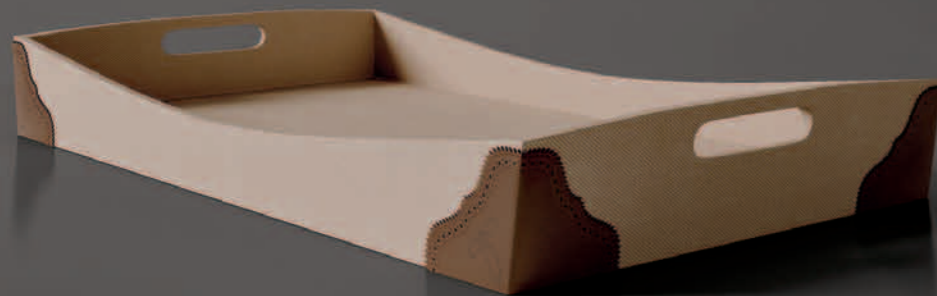

# Frame

Cornice con struttura in legno interamente rivestita in pelle e dettaglio logato in ottone bronzato.

*Frame with wooden structure, covered entirely in leather and branded detail in bronze-plated brass.*

**Art.2100\_FRAME**

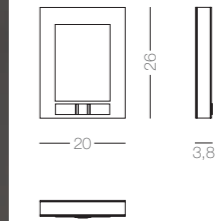

# Chic

Gruccia con struttura in legno, rivestita in pelle con patella centrale personalizzabile. Cuciture realizzate a mano. Preziosi dettagli in ottone bronzato.

*Hanger with wooden frame, covered in leather with customizable central flap. Stitched by hand. Beautiful details in bronze-plated brass.*

**Art.2200/A\_CHIC**

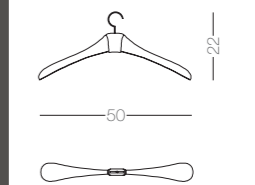

**Art.2200/B\_CHIC**

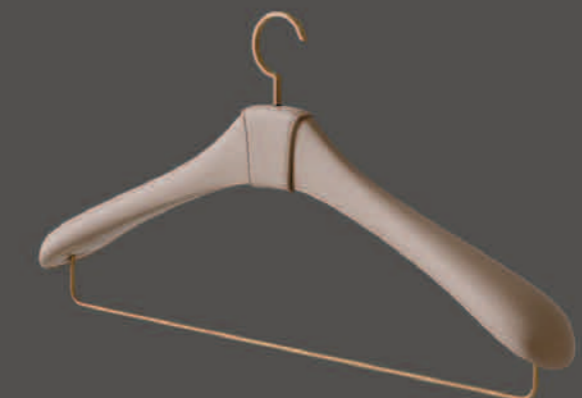
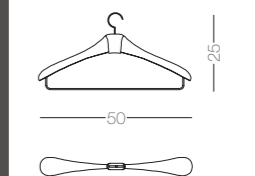

# Collezione “Compass”

Borsa Weekend realizzata in vero cocodrillo (Crocodycus Porosus) con interno in Cashmere e dettagli logati “Ludovica Mascheroni”.

*Weekend bag in genuine crocodile leather (Crocodycus Porosus) with Cashmere lining and “Ludovica Mascheroni” branded details.*

**Art.2300\_COLLEZIONE “COMPASS”**





# Collezione “Compass”

Borsa 24 h realizzata in vero struzzo con interno in Cashmere e dettagli logati “Ludovica Mascheroni”.

*Briefcase in genuine ostrich, Cashmere lining and “Ludovica Mascheroni” branded details.*

**Art.2301\_COLLEZIONE “COMPASS”**

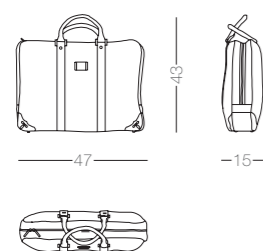

# Collezione “Compass”

Trolley realizzato in vero struzzo con interno in Cashmere e dettagli logati “Ludovica Mascheroni”.

*Trolley rolling suitcase in genuine ostrich, Cashmere lining and “Ludovica Mascheroni” branded details.*

**Art.2302\_COLLEZIONE “COMPASS”**

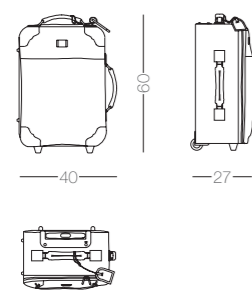

# Legn

Pavimento con struttura in legno rivestito in pelle. Venatura pantografata a rilievo.

*Flooring with wooden structure covered in leather. Pantographed grain in relief.*

**Art.2201\_LEGN**

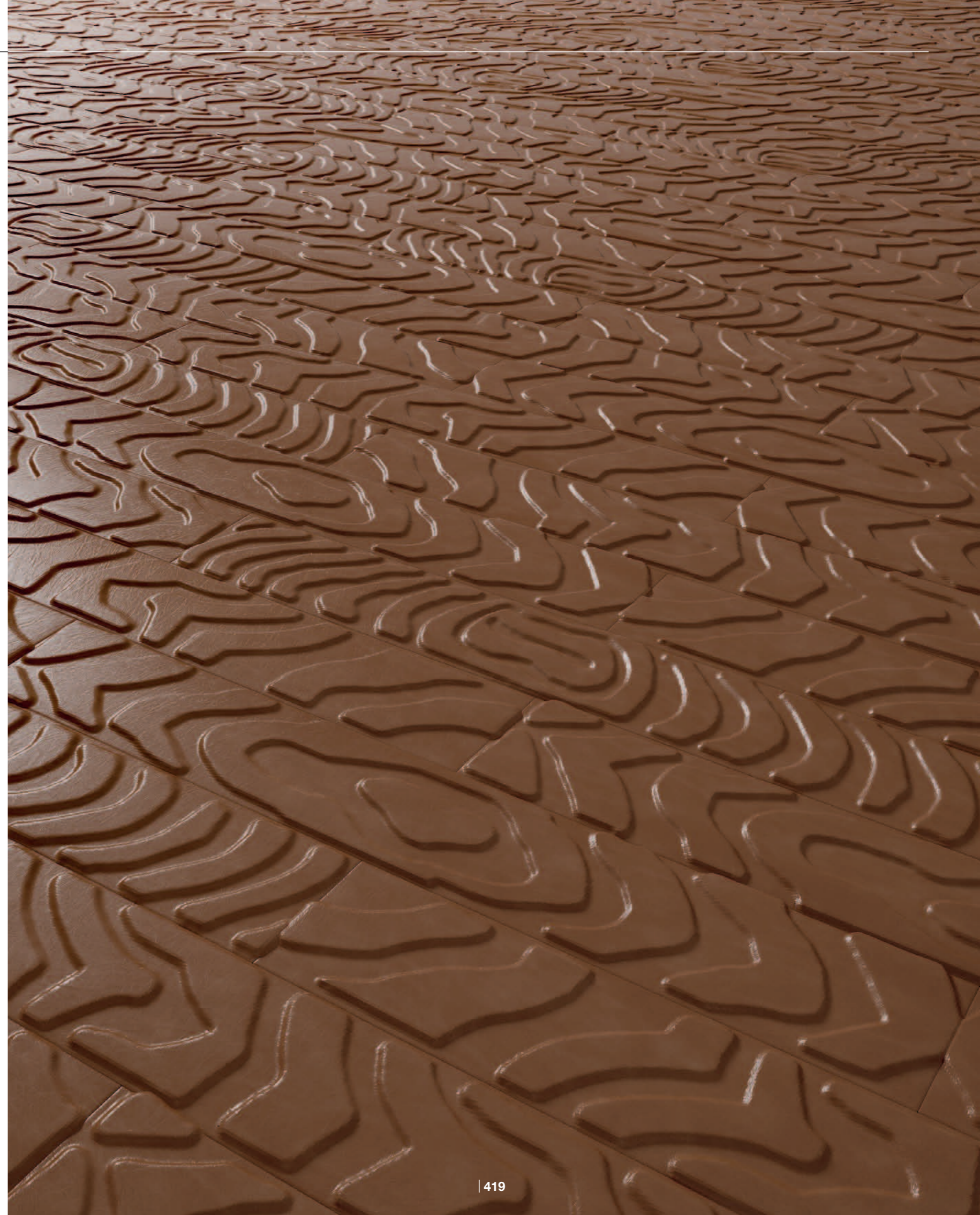
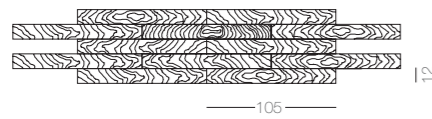

# Sass

Pavimento con struttura in legno rivestito in pelle. Texture pantografata a rilievo.  
*Flooring with wooden structure covered in leather. Pantographed texture in relief.*

**Art.2202\_SASS**

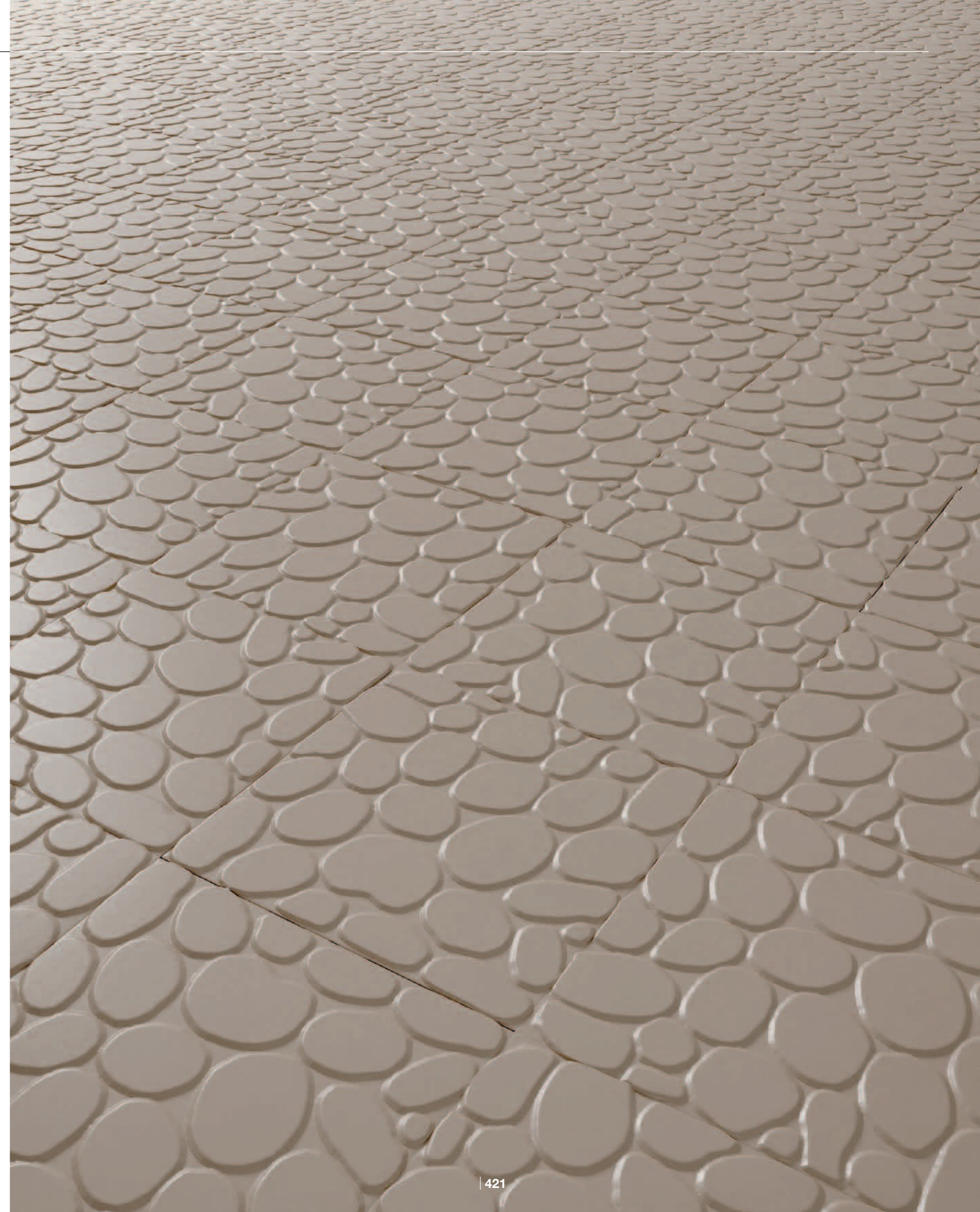
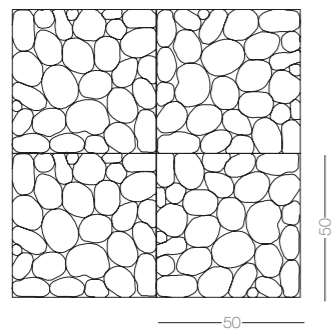

# Passepartout

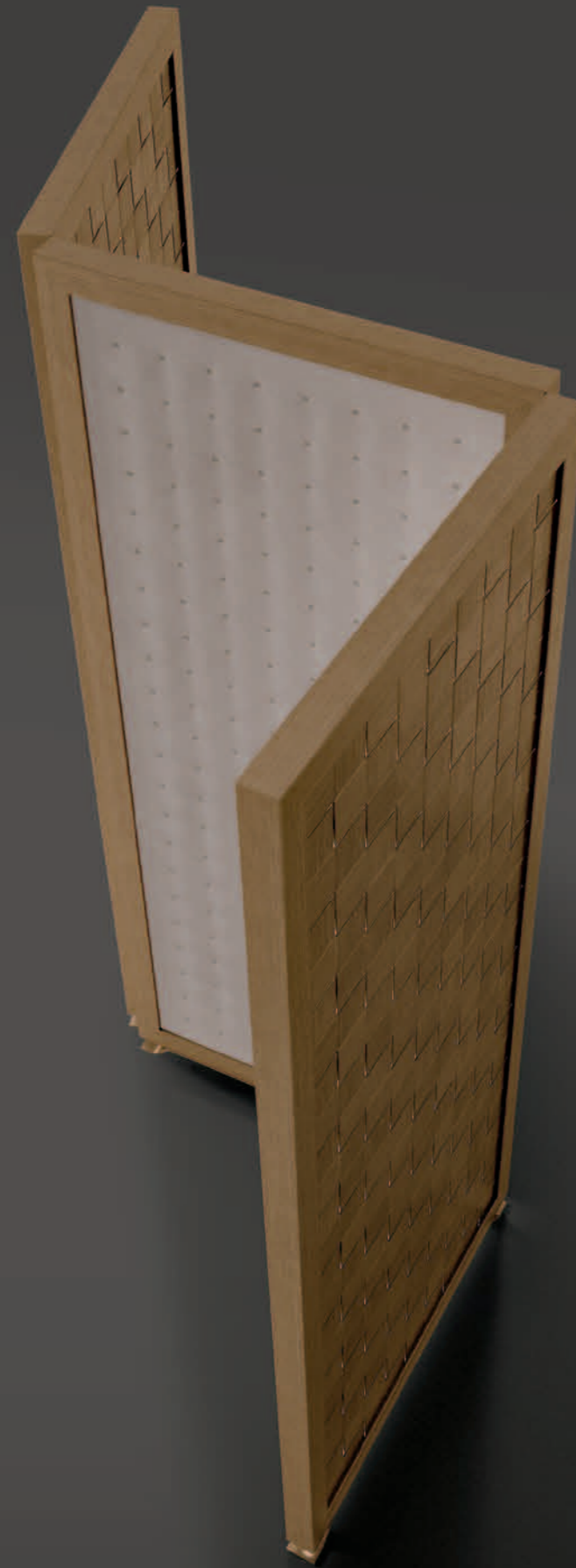

Art.2401\_PASSEPARTOUT

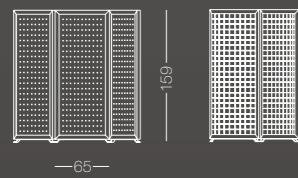

Paravento con struttura in ottone bronzato, pannelli bifacciali con un lato rivestito in Nubuck impunturato e un lato in ottone bronzato con sistema di intreccio.

Screen with frame in bronze-plated brass, two-sided panels with one side covered in backstitched Nubuck and one side in bronze-plated brass with interwaving.

I materassi e  
il sommier  
The mattresses  
and bed base



# I materassi

The mattresses



# I materassi

## The mattresses



**Materasso modello ortopedico con molleggio tradizionale 2.2 h cm 22/25.**

Materasso con rivestimento esterno in tessuto Cashmere personalizzato; imbottitura lato estivo in cotone bianco, lato invernale in lana bianca; poliuretano espanso indeformabile e feltro agugliato termo fissato ad alta densità; molleggio a molle tradizionali ortopedico in acciaio temperato armonico diametro 2.20; sistema box, tamponi perimetrali in poliuretano espanso indeformabile D.30 kg/mq, ad alta resistenza.

**Orthopaedic mattress with traditional suspension system: 2.2 h cm 22/25.**

*Mattress with outer covering in personalized Cashmere; summer side padding in white cotton, winter side in white wool; expanded non-deformable polyurethane and needled felt with thermal-set high density; traditional orthopaedic suspension on springs in hardened spring steel with a diameter of 2.20; box System, perimeter pads in expanded non-deformable polyurethane with density of 30 kg/sqm – high strength.*



**Materasso modello ortopedico con molleggio tradizionale 2.2 h cm 22/25 con Memory.**

Lastra in materiali modellanti Memory Foam; materasso con rivestimento esterno in tessuto Cashmere personalizzato; imbottitura lato estivo in cotone bianco, lato invernale in lana bianca; poliuretano espanso indeformabile e feltro agugliato termo fissato ad alta densità; molleggio a molle tradizionali ortopedico in acciaio temperato armonico diametro 2.20; sistema box, tamponi perimetrali in poliuretano espanso indeformabile D.30 kg/mq, ad alta resistenza.

**Orthopaedic mattress with traditional suspension system: 2.2 h cm 22/25 with Memory Foam.**

*Memory Foam sheet mattress; mattress with outer covering in personalized Cashmere; summer side padding in white cotton, winter side in white wool; expanded non-deformable polyurethane and needled felt with thermal-set high density; traditional orthopaedic suspension on springs in hardened spring steel with a diameter of 2.20; box System, perimeter pads in expanded non-deformable polyurethane with density of 30 kg/sqm – high strength.*

**Materasso con molle indipendenti h cm 22/25.**

Materasso con rivestimenti interni ed esterni in tessuto Cashmere personalizzato; imbottitura lato estivo in cotone bianco, lato invernale in lana; poliuretano espanso indeformabile e feltro agugliato termo fissato ad alta densità; molleggio a molle insacchettate indipendenti a 7 zone di portata differenziata in acciaio temperato armonico diametro 2.0 - 2.20; sistema box, tamponi perimetrali in poliuretano espanso indeformabile D.30 kg/mq, ad alta resistenza.

**Mattress with independent springs: h 22/25 cm.**

*Mattress with outer and inner covering in personalized Cashmere; summer side padding in white cotton, winter side in white wool; expanded non-deformable polyurethane and needled felt with thermal-set high density; suspension with independent pocket springs in 7 different support areas in hardened spring steel with a diameter of 2.20; box System, perimeter pads in expanded non-deformable polyurethane with density of 30 kg/sqm – high strength.*



**Materasso modello ortopedico con molleggio tradizionale 3.0 h più Topper in Memory/Water air/Water gel.**

Materasso con rivestimento esterno in tessuto Cashmere personalizzato rimovibile e lavabile; imbottitura lato in Memory/Water air/Water gel; rivestimento interno in tessuto Cashmere personalizzato; poliuretano espanso indeformabile e feltro agugliato termo fissato ad alta densità; molleggio a molle tradizionali ortopedico in acciaio temperato armonico diametro 2.20; sistema box, tamponi perimetrali in poliuretano espanso indeformabile D.30 kg/mq, ad alta resistenza.

**Orthopaedic mattress with traditional suspension system: 3.0 h plus Topper in Memory-Water air-Water gel combination.**

*Mattress with outer covering in personalized Cashmere that is removable and washable; padding in Memory-Water air-Water gel combination; inner covering in personalized Cashmere; expanded non-deformable polyurethane and needled felt with thermal-set high density; traditional orthopaedic suspension on springs in hardened spring steel with a diameter of 2.20; box System, perimeter pads in expanded non-deformable polyurethane with density of 30 kg/sqm – high strength.*





# Il sommier

## The bed base



Il sommier è l'ideale per coloro che amano il letto semplice e funzionale e l'arredo libero da schemi; il sommier, non avendo la testata, è posizionabile come si vuole nel locale, sotto un grande arazzo oppure sotto la finestra. E' una soluzione molto impiegata negli hotel.

*The bed base is ideal for those who love a simple and practical bed, along with furnishings that break the common mould; the bed base, seeing that it doesn't have a headboard, can be positioned anywhere you want in the room, beneath a large tapestry or even below the window. This is a solution that is used a great deal by hotels.*



Dettaglio chiodatura tela di sottofondo  
Detail of nail-work canvas in background



Dettaglio molle biconiche  
Detail of biconical springs

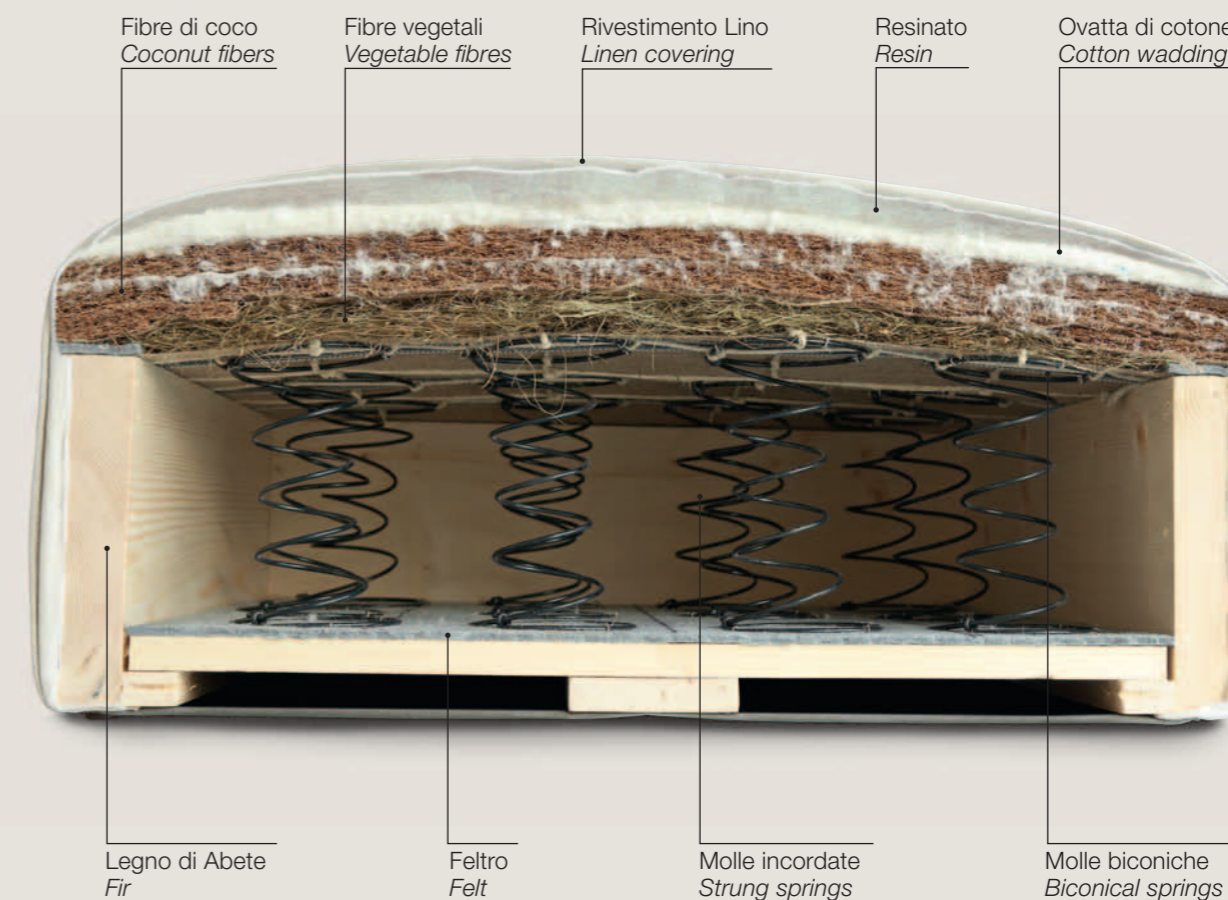

# Indice sinottico

## Synoptic Index

Boiserie Collection



Art. 101 - GIGLIO Pag.10



Art. 102 - SERENA Pag.12

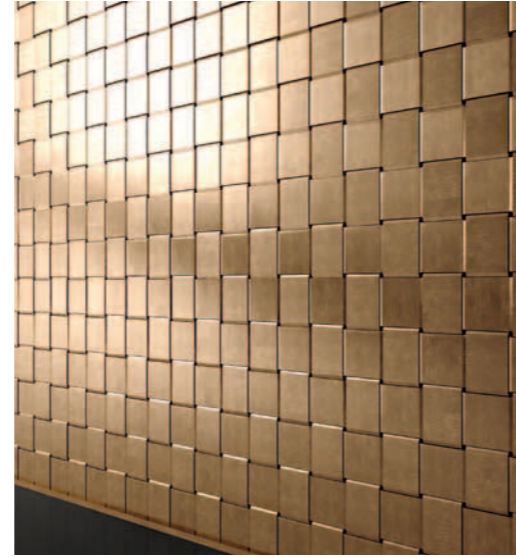

Art. 103 - INTRIGO 15 Pag.14



Art. 110 - ARMONY Pag.30



Art. 111 - INTRECCIO 45° Pag.32



Art. 111 - INTRECCIO 90° Pag.34

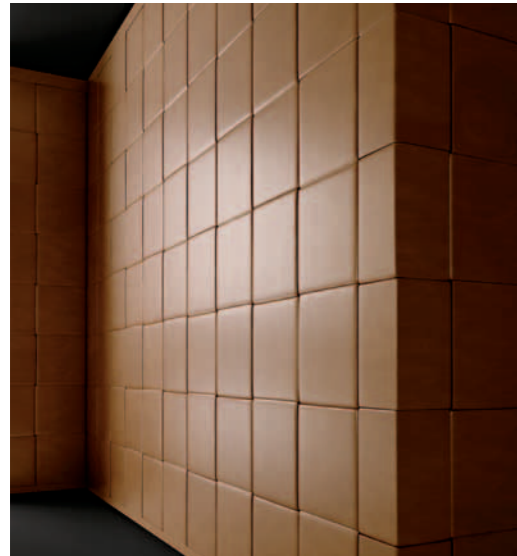

Art. 103 - INTRIGO 30 Pag.18

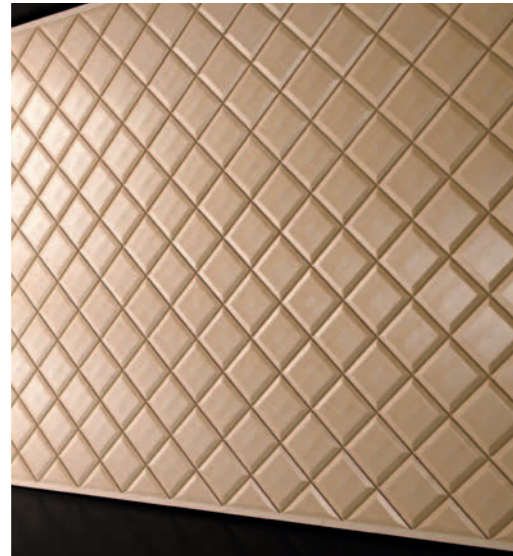

Art. 104 - MALDIVE Pag.20



Art. 105 - EDRA Pag.22



Art. 112 - ATLAS Pag.36



Art. 113 - CAFÉ ROYAL Pag.38



Art. 114 - PROMETEO Pag.40



Art. 106 - VERDIANA Pag.24



Art. 107 - CHEOPE Pag.26



Art. 109 - OXFORD Pag.28



Art. 115 - ESMERALDA Pag.42

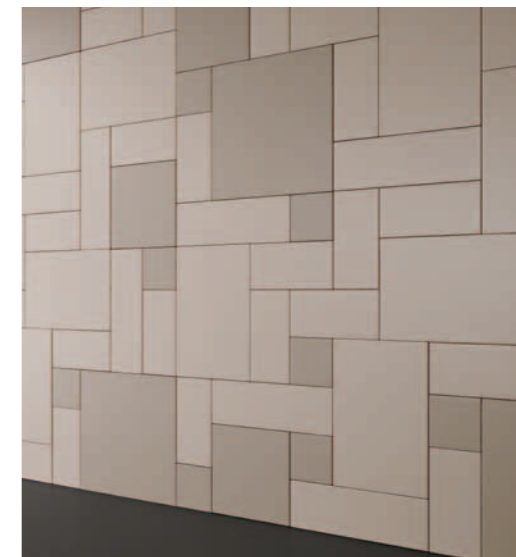

Art. 116 - MONDRIAN Pag.44

Oxford Collection



Art. 109 Pag.28



Art. 1604 Pag. 362



Art. 1703 Pag.256



Art. 1208 Pag.274



Art. 1210 Pag.278



Art. 206 Pag.72



Art. 311 Pag.74



Art. 505 Pag.138



Art. 1112 Pag.328



Art. 1310/A Pag.330



Art. 1404 Pag.332



Art. 409 Pag.124



Art. 305 Pag.108



Art. 708 Pag.190



Art. 310 Pag.194



Art. 607 Pag.156



Art. 1806 Pag.378



Art. 905 Pag.228



Art. 309 Pag.192



Art. 1506 Pag.352



Art. 804/A Pag.210



Art. 806 Pag.212



Art. 1002 Pag.242



Art. 1705 Pag.244

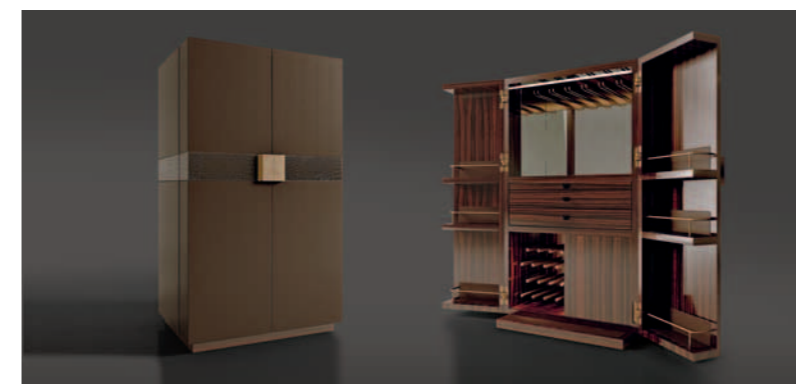

Art. 1004 Pag.338



Art. 2106 Pag.402



Art. 317 Pag.110

## Dorian Collection



Art. 805 Pag.214



Art. 908 Pag.234



Art. 1003 Pag.246



Art. 1704 Pag.248

## Edra Collection



Art. 1205 Pag.268



Art. 506 Pag.140



Art. 1109 Pag.322



Art. 1106 Pag.302



Art. 1309 Pag.304



Art. 1403 Pag.306

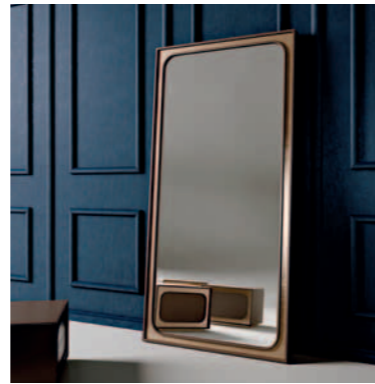

Art. 1807/B Pag.380



Art. 1305 Pag.324

## Armony Collection



Art. 110 Pag.30



Art. 207 Pag.76



Art. 306 Pag.78

## Prissy Collection



Art. 303 Pag.102



Art. 401 Pag.104



Art. 1201 Pag.260

## Eclisse Collection



Art. 405 Pag.80



Art. 504 Pag.136



Art. 410 Pag.126

## Alias Collection



Art. 1805 Pag.376



Art. 1103 Pag.290



Art. 1301 Pag.292



Art. 1401 Pag.294

**Chelsea Collection**



Art. 608 Pag.158



Art. 709 Pag.196



Art. 1505 Pag.350



Art. 1810 Pag.384

**Argo Collection**



Art. 602 Pag.146

**Fantasma Collection**



Art. 702 Pag.174



Art. 702/P Pag.176



Art. 702/D Pag.178

**Basilia Collection**



Art. 601 Pag.144



Art. 701/P Pag.168



Art. 701 Pag.170



Art. 901 Pag.222

**Torquato Collection**



Art. 403 Pag.116



Art. 1501 Pag.342

**Altai Collection**



Art. 902 Pag.224



Art. 1202 Pag.262



Art. 1302 Pag.334

**Clero Collection**



Art. 204/A Pag.62



Art. 204/B Pag.64



Art. 312 Pag.66

**Erasmus Collection**



Art. 1101 Pag.284



Art. 1102 Pag.286



Art. 1311 Pag.288

**Grace Collection**



Art. 1207 Pag.272



Art. 1801 Pag.370

## Loto Collection



Art. 609 Pag.160



Art. 707/B Pag.188



Art. 803/A Pag.208



Art. 906 Pag.230

## Eden Collection



Art. 111 Pag.32



Art. 1206 Pag.270



Art. 910 Pag.238

## Intrigo Collection

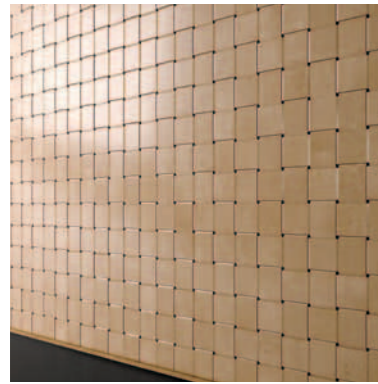

Art. 103 Pag.16



Art. 1203 Pag.264



Art. 1802 Pag.372



Art. 1111 Pag.308



Art. 1304 Pag.310



Art. 1405 Pag.312



Art. 1107 Pag.314



Art. 1108 Pag.316



Art. 1308 Pag.318



Art. 1107 Pag.320



Art. 909 Pag.236

## Xeno Collection



Art. 1809 Pag.382



Art. 1503 Pag.346

## Quadro Collection



Art. 407 Pag.120



Art. 408 Pag.122

## Stilo Collection



Art. 907 Pag.232



Art. 1504 Pag.348

## Twin-Bridge Collection



Art. 501 Pag.130

## Eliot Collection



Art. 502/A Pag.132

### Phoenix Collection



Art. 611 Pag.162



Art. 710 Pag.198



Art. 807 Pag.216

### Eloro Collection



Art. 205 Pag.68



Art. 307 Pag.70



Art. 503 Pag.134

### Skyline Collection

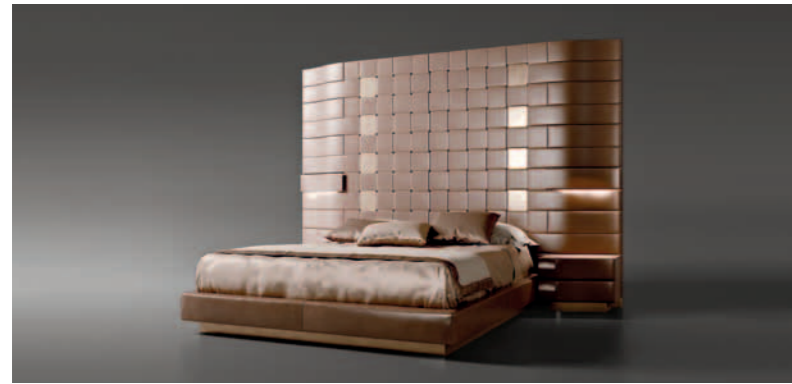

Art. 1209 Pag.276



Art. 1110 Pag.326



Art. 1811



Art. 1204 Pag.266



Art. 1104 Pag.296



Art. 1303 Pag.298

### Maldivo Collection



Art. 104 Pag.20



Art. 605 Pag.152



Art. 705 Pag.184



Art. 802/A Pag.206

### Odeon Collection

Pag.386

### Sophia Collection



Art. 1402 Pag.300



Art. 304 Pag.106

### Doralice Collection



Art. 603 Pag.148



Art. 801/A Pag.204



Art. 903 Pag.226



Art. 703 Pag.180

### Globo Collection



Art. 606 Pag.154

### Luna Collection



Art. 706 Pag.186

### Venere Collection



Art. 404 Pag.118



Art. 1502 Pag.344



**Privè Collection**



Art. 202

Pag.52



Art. 313

Pag.54

**Cubo Collection**



Art. 402

Pag.114

**Clessidra Collection**



Art. 211

Pag.92

**Aura Collection**



Art. 302

Pag.100

**Prometeo Collection**



Art. 208

Pag.82



Art. 315

Pag.84

**Trevis Collection**



Art. 203

Pag.56



Art. 308

Pag.58



Art. 406

Pag.60

**Ermelin Collection**



Art. 201

Pag.48



Art. 314

Pag.50

**Edra Collection**



Art. 105

Pag.22

**Ninfea Collection**



Art. 1803

Pag.374

**Lord Collection**



Art. 209

Pag.86



Art. 212

Pag.88



Art. 316

Pag.90

**Tolomeo Collection**



Art. 604

Pag.150

**Artemide Collection**

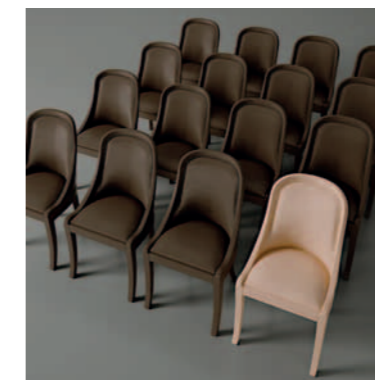

Art. 704

Pag.182

### Diletta Collection



Art. 1702 Pag.254

### Serena Collection



Art. 1701/A Pag.250



Art. 1701/B Pag.252

### Alice Collection



Art. 1601 Pag.356

### Titano Collection



Art. 213/A Pag.94



Art. 213/B Pag.96



Art. 318 Pag.98

### Ariel Collection



Art. 1602 Pag.358

### Balmoral Collection



Art. 612 Pag.164



Art. 711 Pag.200



Art. 808 Pag.218

### Arluna Collection



Art. 1603 Pag.360

### Jackie Collection



Art. 1005 Pag.340

### Oxford Collection



Art. 1004 Pag.338

### Oxford Club Collection



Art. 1604 Pag.362

Tricot Collection



Art. 2103

Pag.392



Art. 2104

Pag.394



Art. 2105

Pag.396

Oxford Collection



Art. 2106

Pag.402



Art. 2107

Pag.404



Art. 2110

Pag.406



Art. 2108

Pag.398



Art. 2109

Pag.400

Collezioni Lampada Amery



Art. 2101

Pag.390



# I materiali Materials

# Marmi Marbles



BIANCO CARRARA  
CARRARA WHITE



BLACK AND GOLD  
BLACK AND GOLD

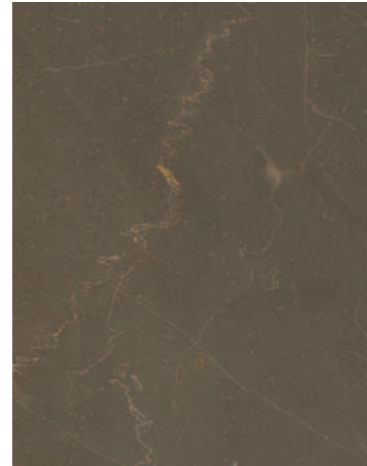

BRONZE AMANI  
AMANI BRONZE

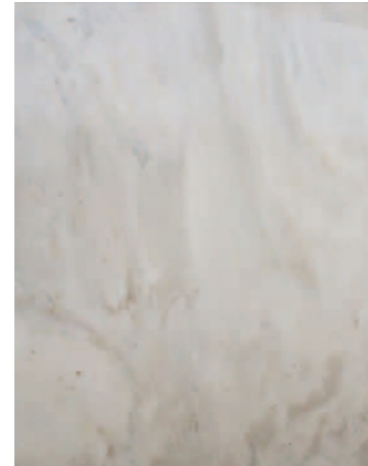

CREMA DELICATO  
DELICATE CREAM



ONICE MIELE  
HONEY ONYX

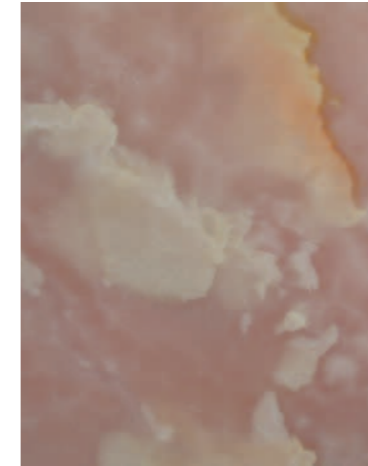

ONICE ROSA  
PINK ONYX

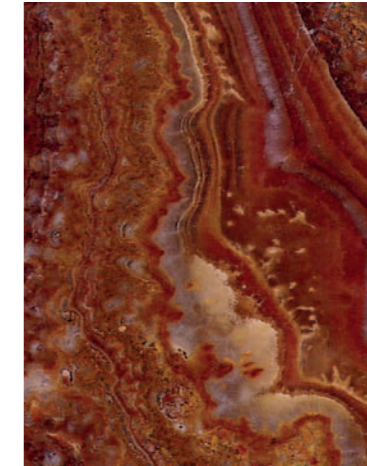

ONICE ROSSO  
RED ONYX



TRAVERTINO CHIARO  
LIGHT TRAVERTINO

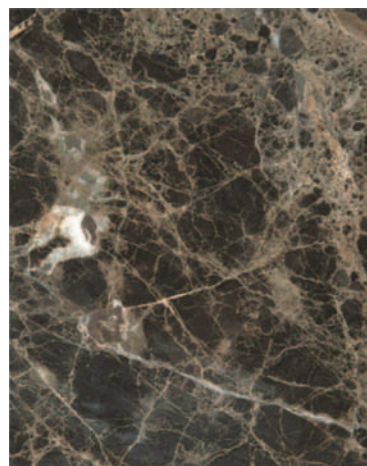

EMPERADOR  
EMPERADOR

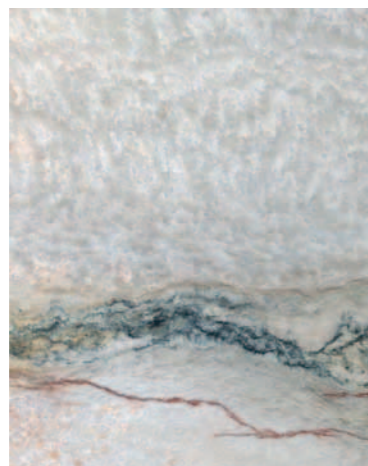

QUARZITE BRASILIANA  
BRAZILIAN QUARTZITE

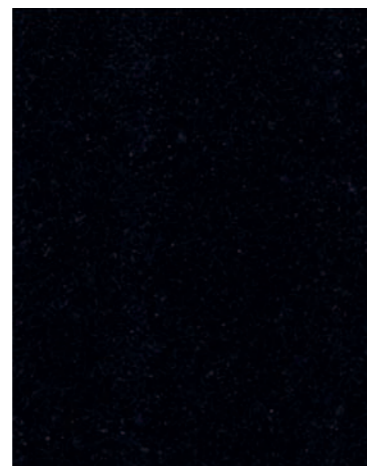

NERO ASSOLUTO  
ABSOLUTE BLACK

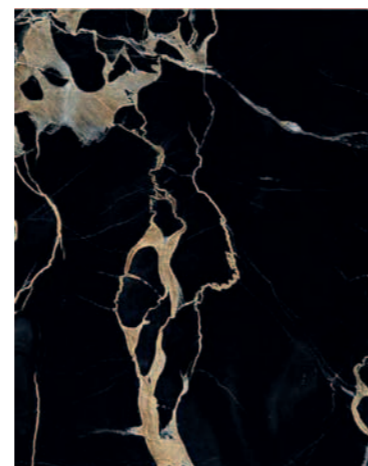

NERO PORTORO  
BLACK PORTORO



CALACATTA ORO  
GOLD CALACATTA

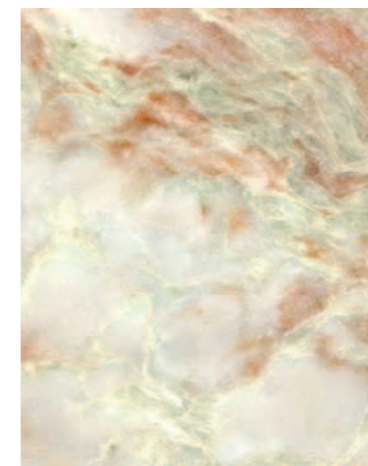

ALBA CHIARA  
CLEAR ALBA



AZUL MACAUBA  
AZUL MACAUBA

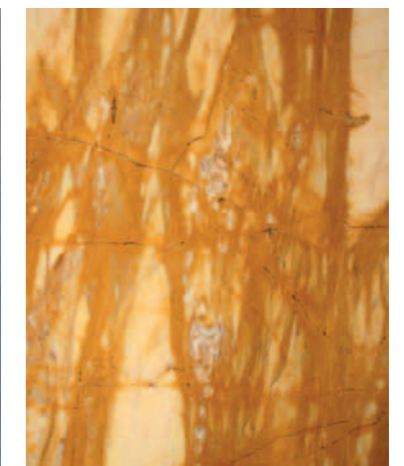

GIALLO SIENA  
YELLOW SIENA

# Essenze

## Essences



ACERO SICOMORO  
SYCAMORE MAPLE



ACERO NATURALE  
NATURAL MAPLE



EBANO MAKASSAR  
MAKASSAR EBONY

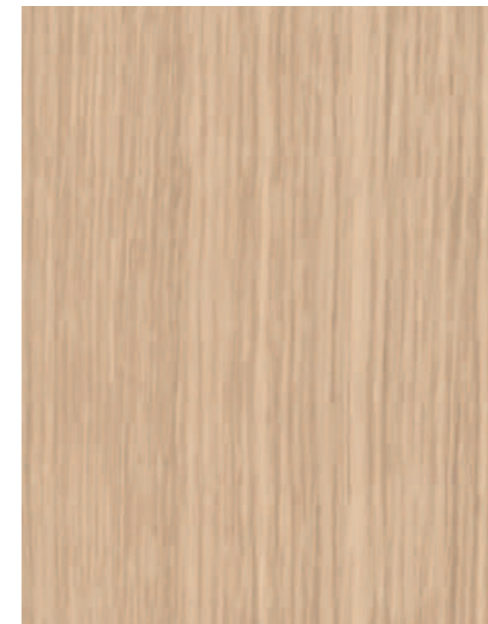

ROVERE NATURALE  
NATURAL OAK



SUCUPIRA  
SUCUPIRA



EUCALIPTO  
EUCALYPTUS



EBANO AMARA  
AMARA EBONY



NOCE CANALETTO  
CANALETTO WALNUT

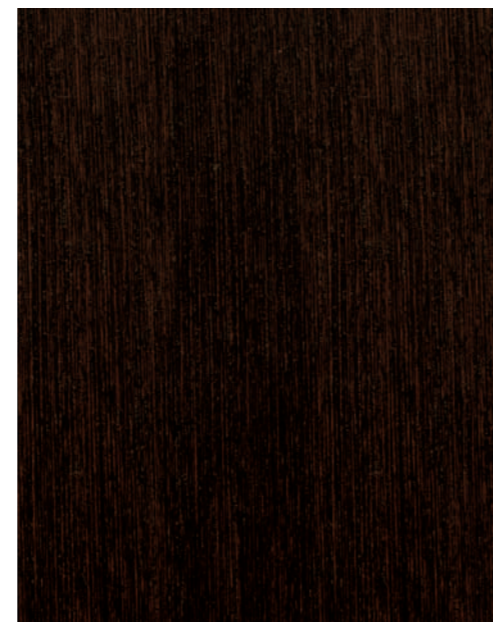

ROVERE MORO  
DARK OAK



ZIRICOTE  
ZIRICOTE



TANGANICA FIAMMATO  
FLAMING TANGANYIKA



PALISSANDRO SANTOS  
SANTOS ROSEWOOD

# Metalli Metals



OTTONE BRONZATO 1  
BRONZE-PLATED BRASS 1

OTTONE BRONZATO 2  
BRONZE-PLATED BRASS 2

OTTONE BRONZATO 3  
BRONZE-PLATED BRASS 3

OTTONE LUCIDO  
BRONZE-PLATED BRASS 3

# Specchi Mirrors

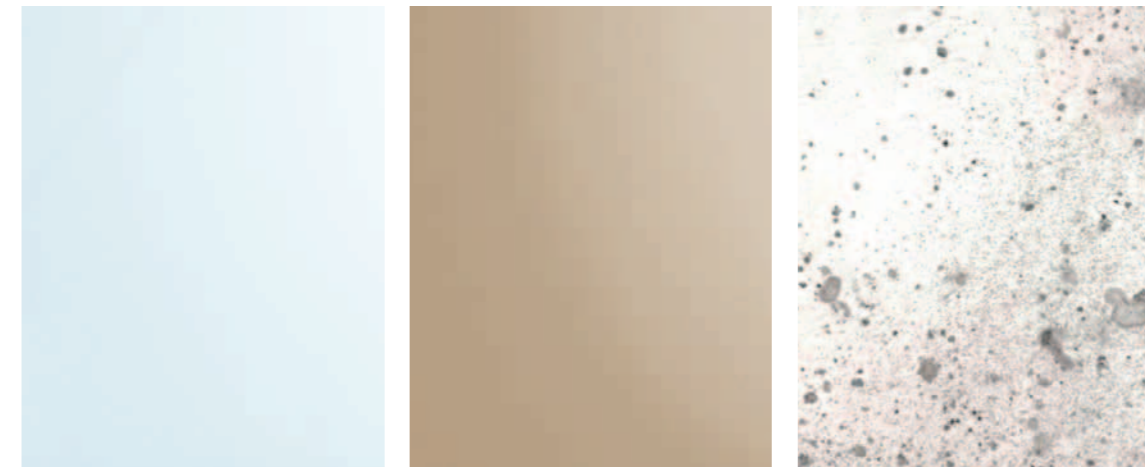

SPECCHIO NATURALE  
NATURAL MIRROR

SPECCHIO BRONZATO  
BRONZE MIRROR

SPECCHIO ANTICO  
ANCIENT MIRROR

# Vetri Glass



SATINATO  
SATIN

CROMO  
CHROME

ARGENTO  
SILVER

NICHEL NERO  
NICKEL BLACK



VETRO EXTRACHIARO  
EXTRACLEAR GLASS

VETRO ACIDATO  
ACID-ETCHED GLASS

VETRO FUMÉ  
FUMÉ GLASS

VETRO SATINATO  
SATIN GLASS

# I lini

The linens

RAPSODIA\_91% LI - 9% PA h. 140 cm.

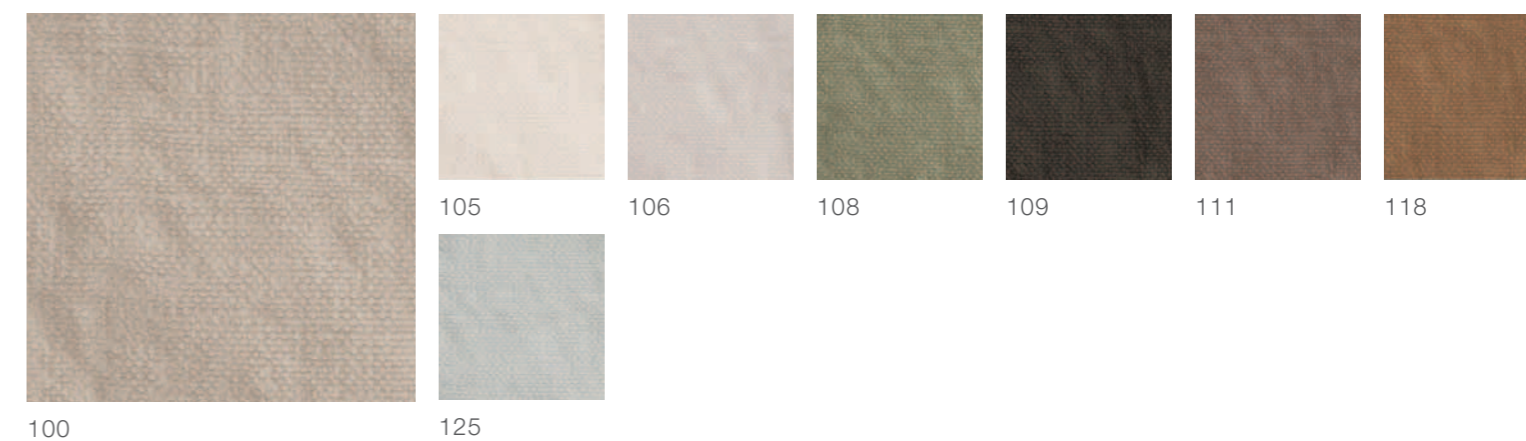

ARMONIA\_100% LI\_h. 140 cm.

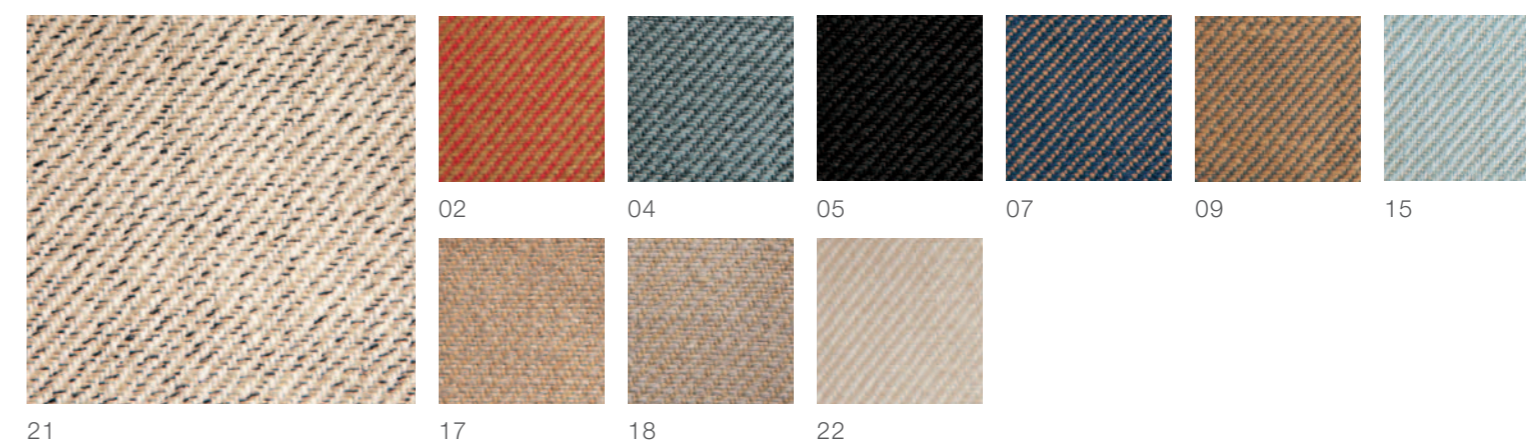

MELODIA\_100% LI \_ h. 140 cm.

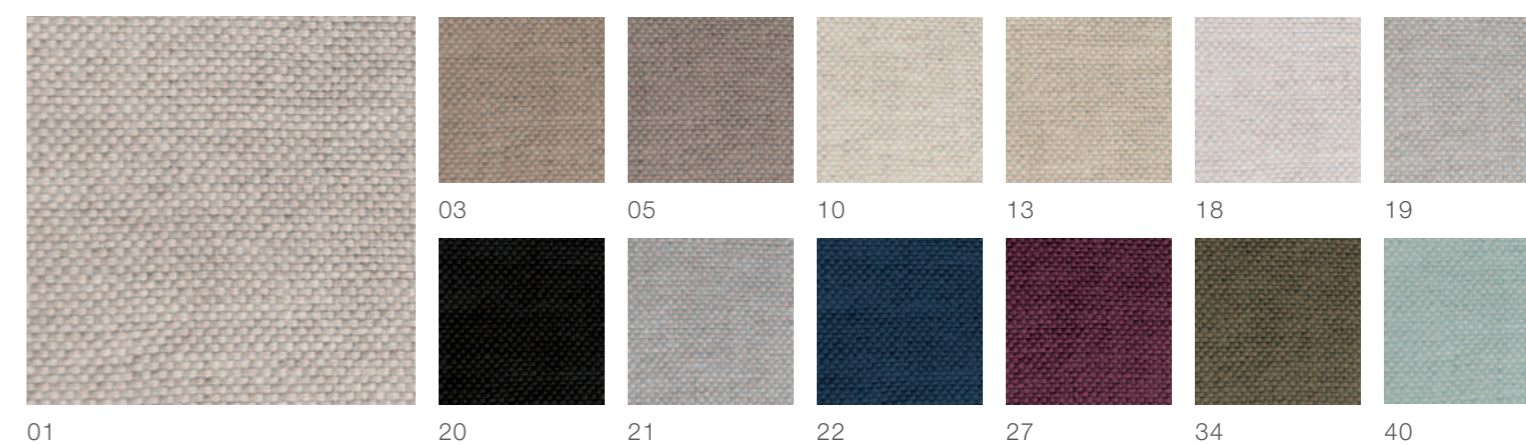



# Le lane The wools

## ROMANZA\_80% LA - 20% PA\_ h. 140 cm.

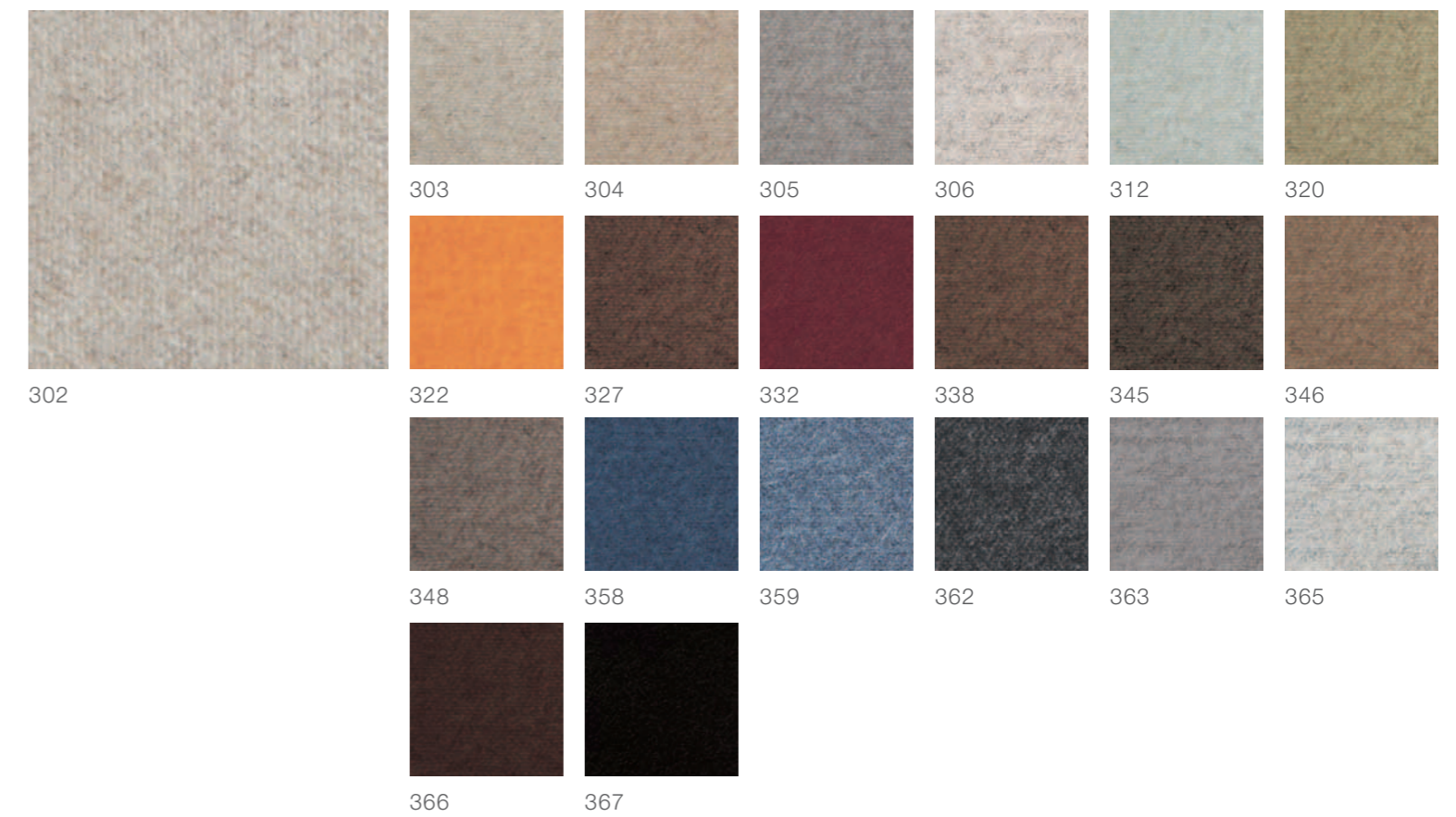

## BALLATA\_100% LA \_ h. 140 cm.

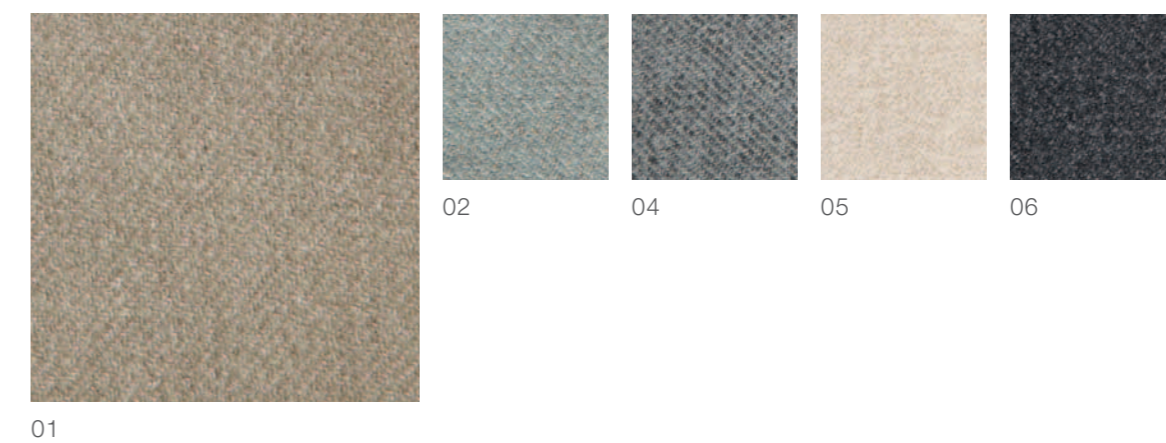

# I cotoni

## The cottons

CONCERTO\_65% CO - 35% PA\_ h. 140 cm.

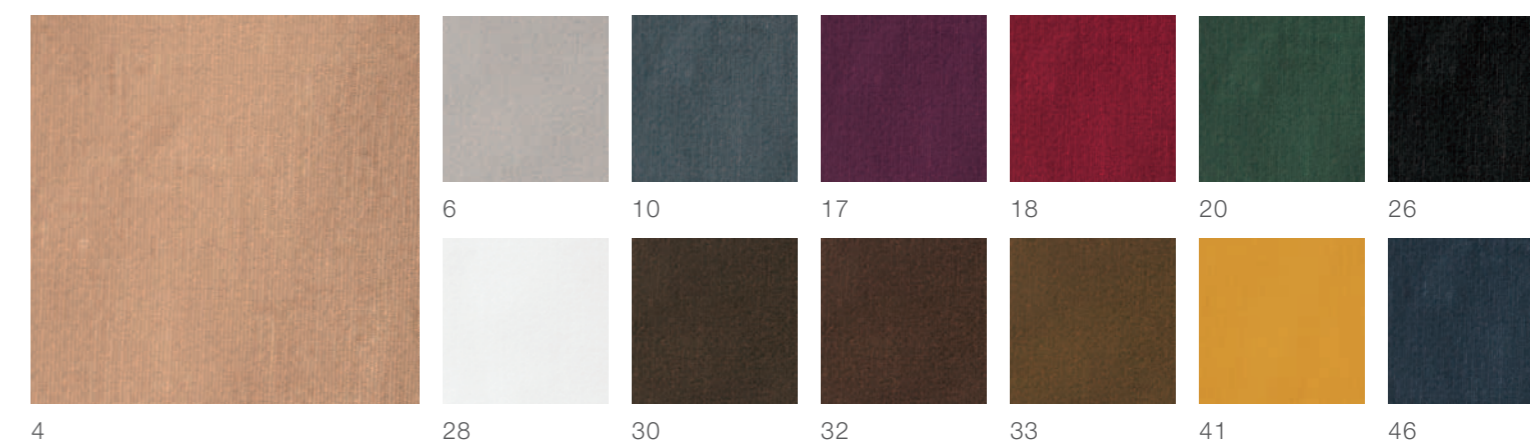

OPERA\_100%CO \_ h. 141 cm.

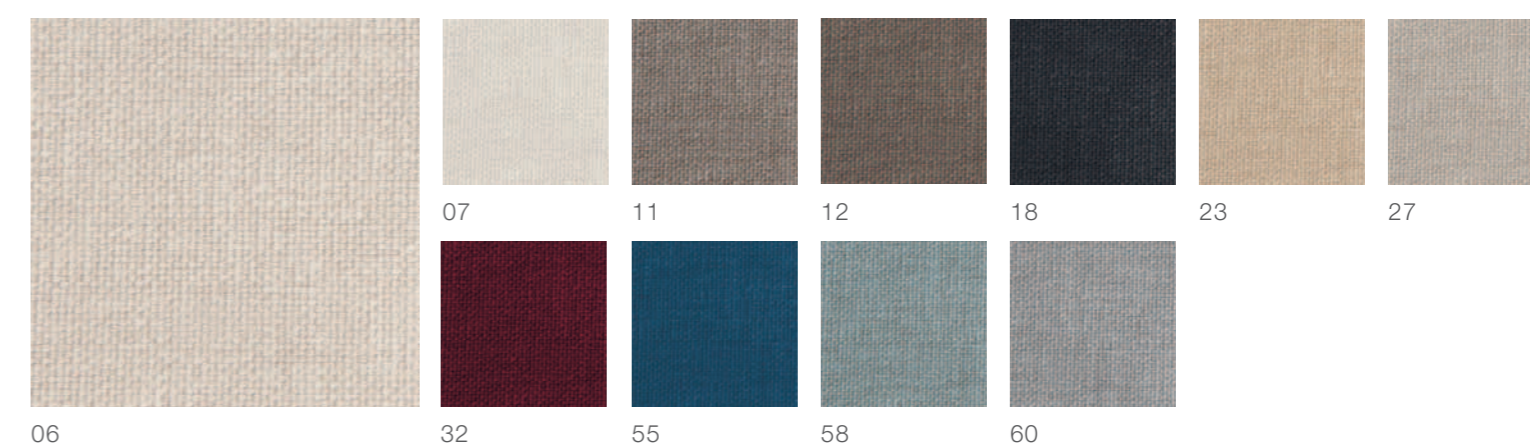

SUITE\_63% CO - 37% LI \_ h. 140 cm.

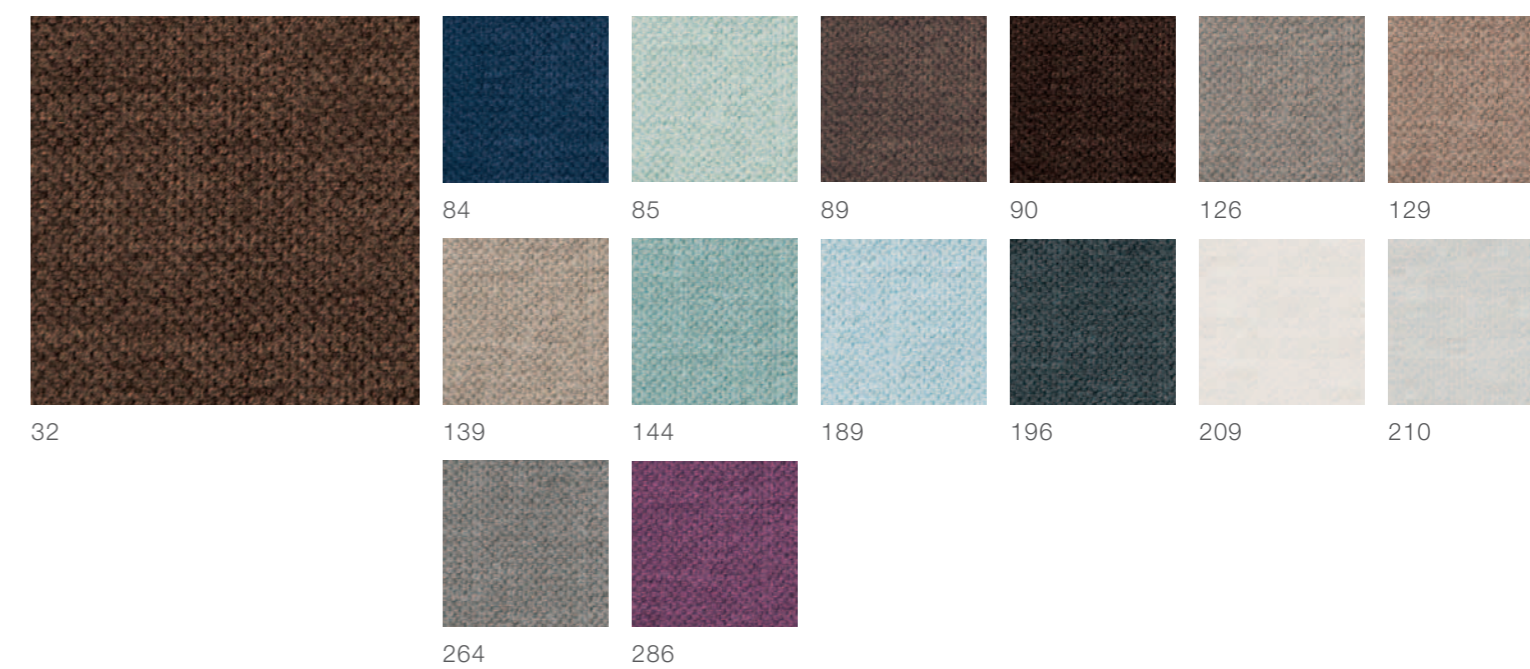

# I velluti

## The velvets

MADRIGALE\_100% SE\_ h. 140 cm.

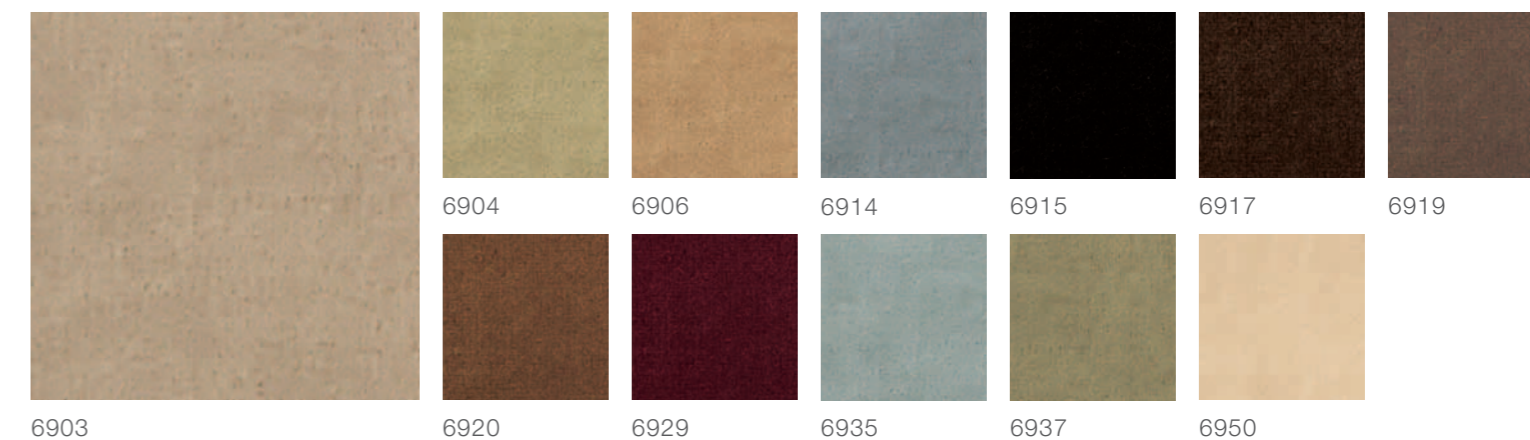

MINUETTO\_100% CO \_ h. 140 cm.

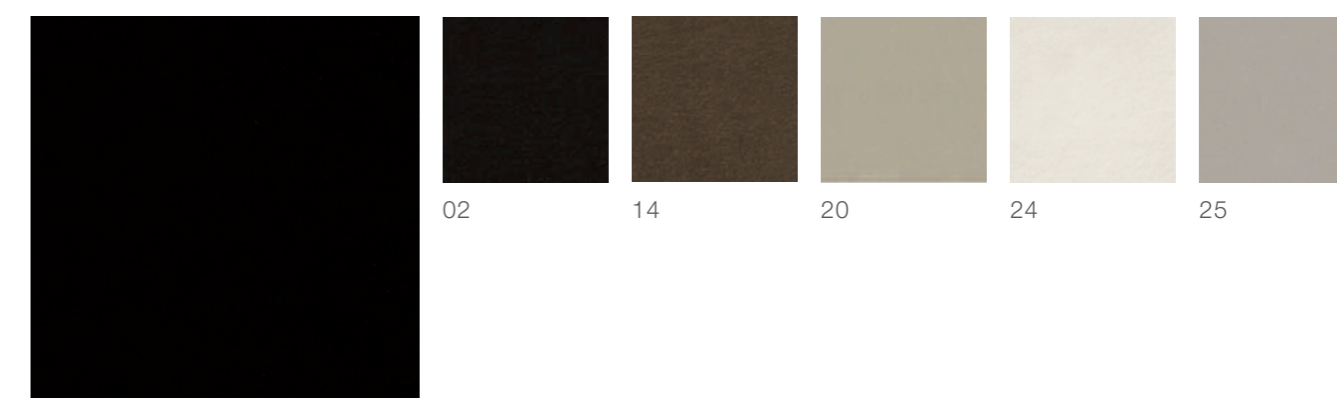

PRELUDIO\_100% TREVIRA CS \_ h. 140 cm.

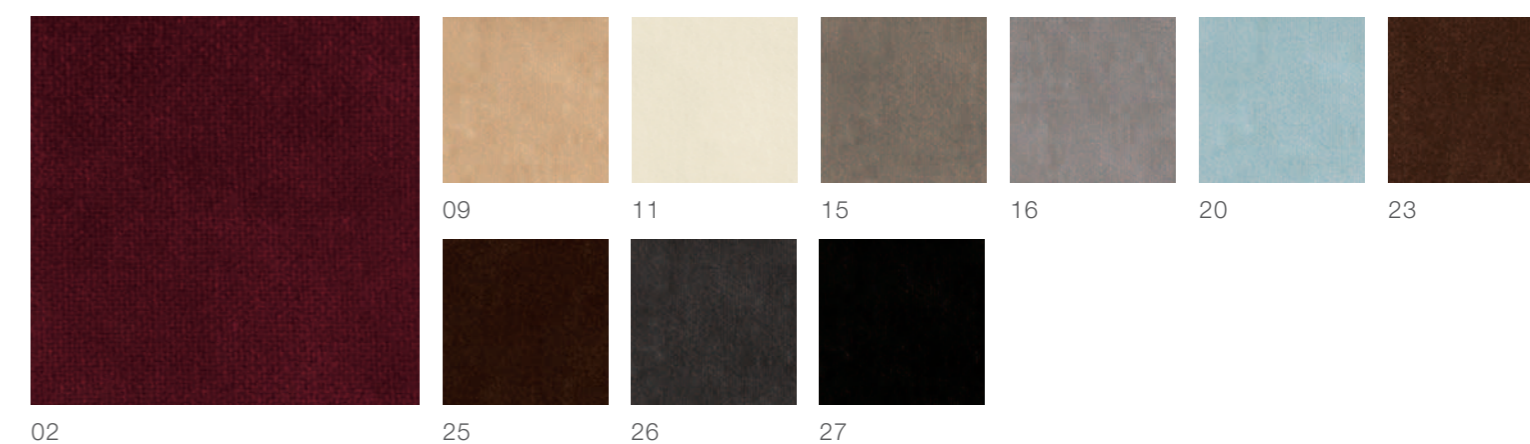

NOTTURNO\_95% CO - 5% PES \_ h. 140 cm.

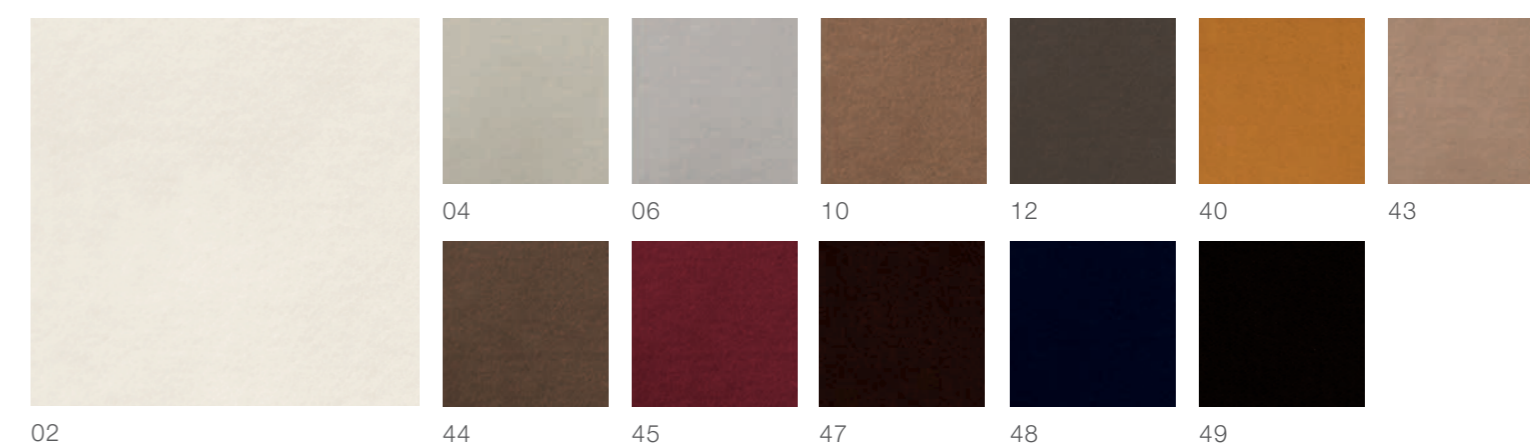

**Il nubuck** Pelli volume 2  
**The nubuck** Leather volume 2

**NABUCCO\_BOVINO EUROPEO\_NUBUCK**



3401

3403

3405

3406

3407

3408

3409

**RIGOLETTO\_TORO EUROPEO\_FIORE NABUCCATO**

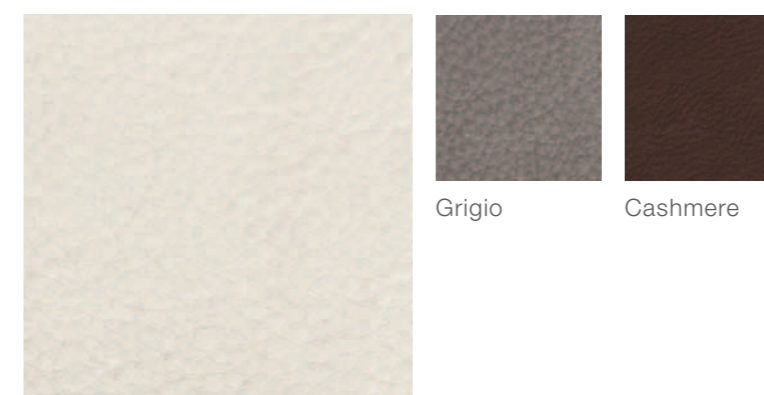

Ghiaccio

Grigio

Cashmere

Le pelli Volumi 1 - 2  
The leathers Volumes 1-2

"VOLUME 1"

SONETTO\_PELLE BOVINA EUROPEA\_MEZZO FIORE GRANA NATURALE  
EUROPEAN COW HIDE, SLIGHTLY BUFFED NATURAL GRAIN

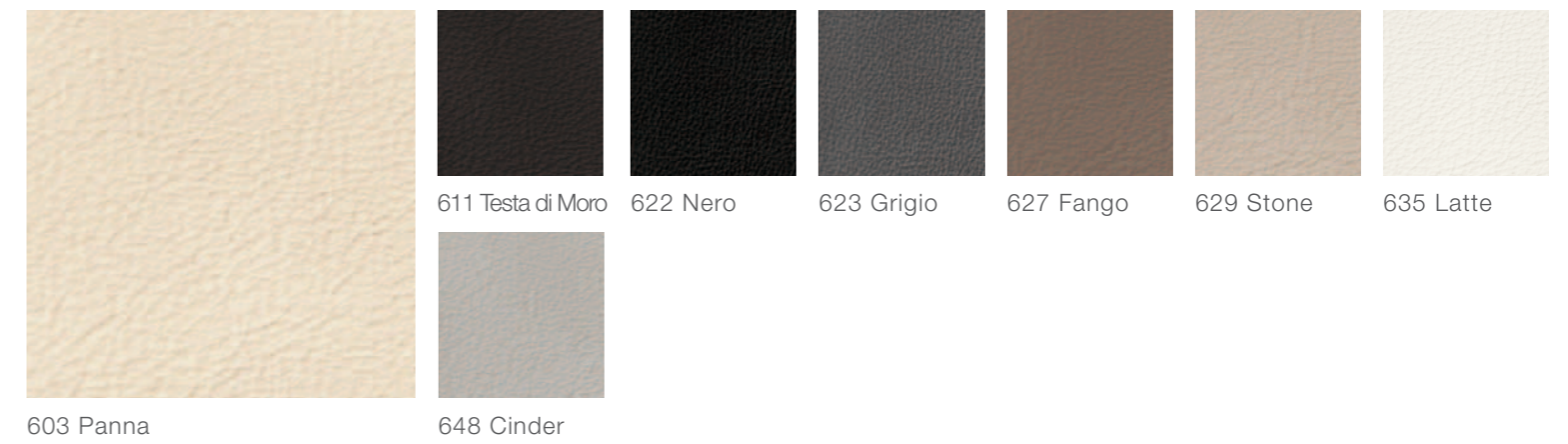

INTERMEZZO\_PELLE BOVINA EUROPEA\_FIORE LISCIO  
EUROPEAN COW HIDE, SMOOTH GRAIN

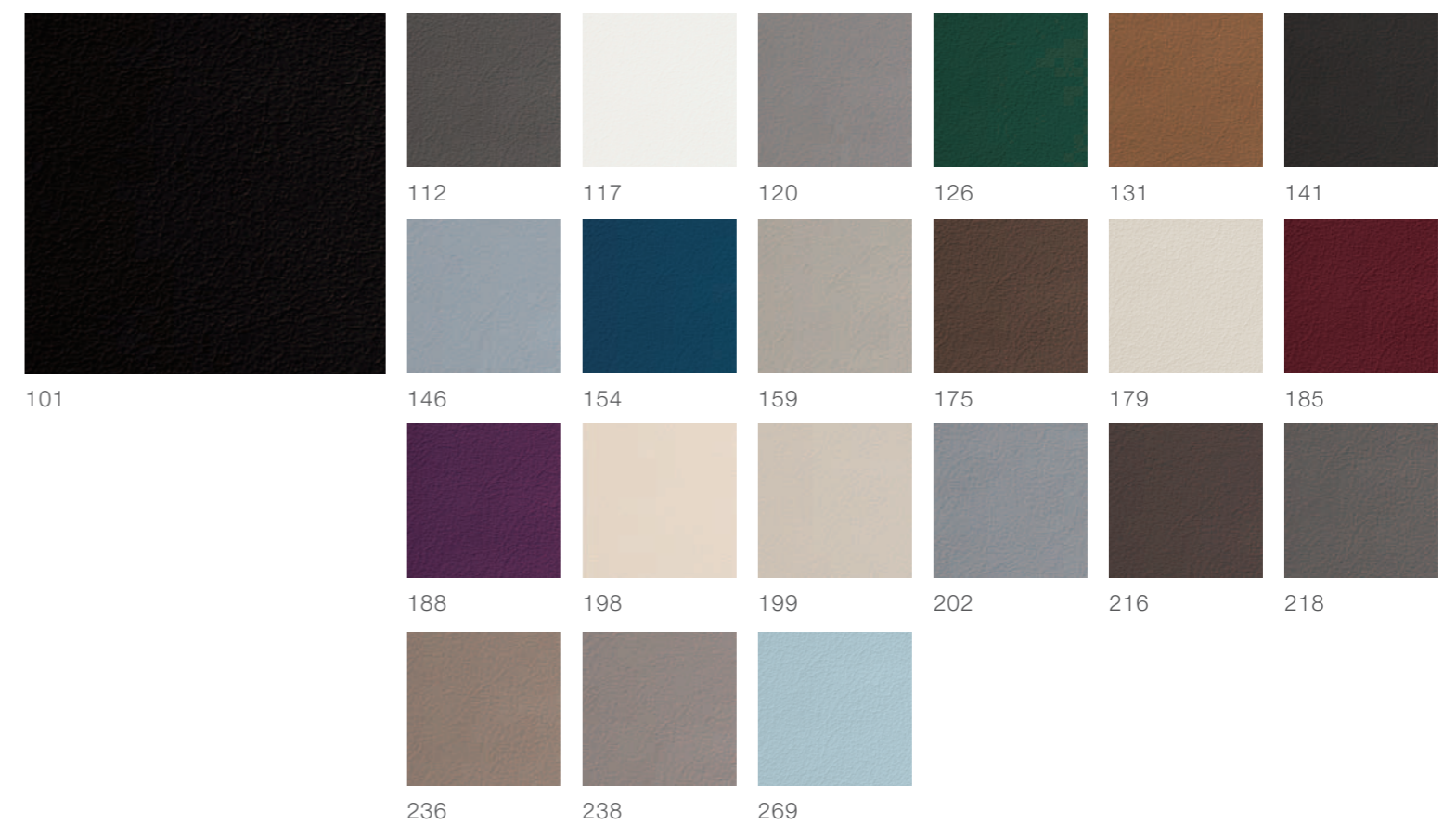

**FUGA\_PELLE BOVINA EUROPEA\_FIORE**  
*EUROPEAN LEATHER, GRAIN*

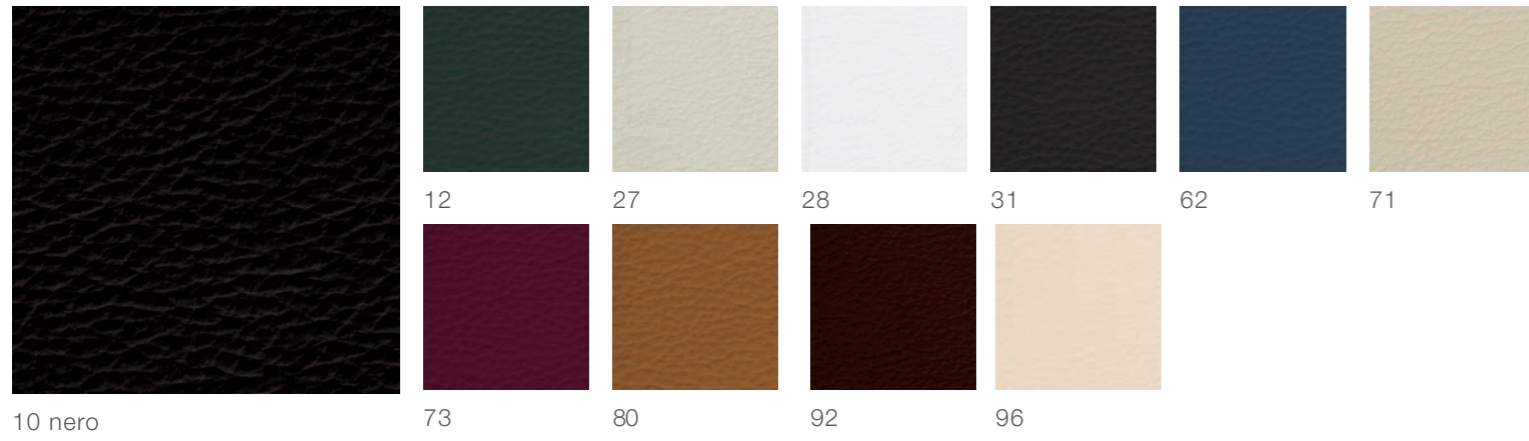

**TURANDOT\_PELLE BOVINA EUROPEA\_PIANO FIORE ANILINA**  
*EUROPEAN COW HIDE, FULL ANILINE GRAIN*



**SERENATA\_PELLE BOVINA EUROPEA\_FIORE GRANA NATURALE**  
*EUROPEAN COW HIDE, NATURAL GRAIN*

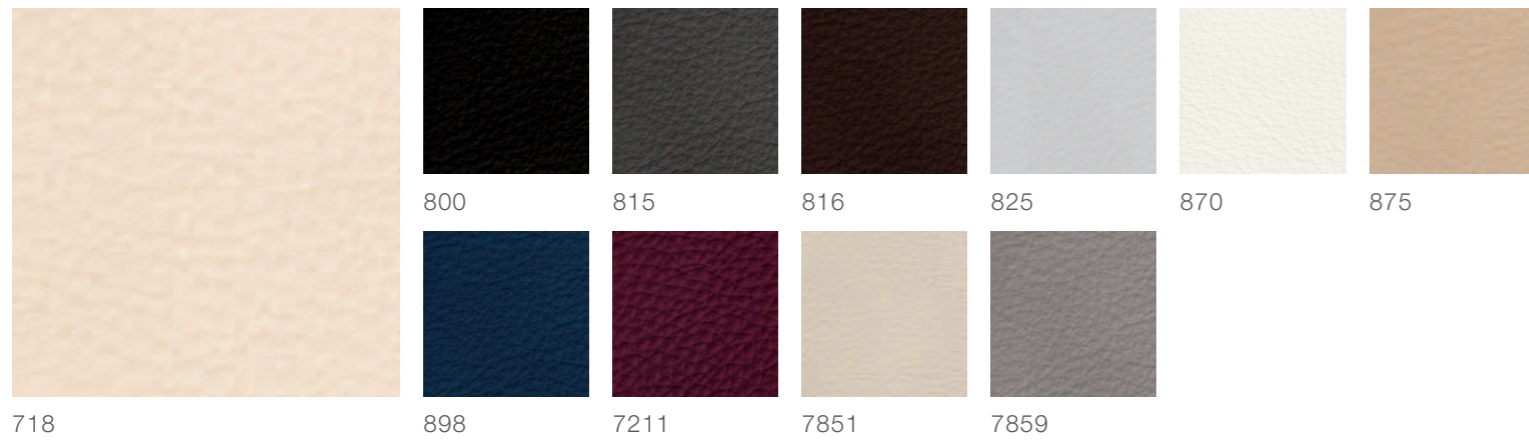

**TRAVIATA\_TORO EUROPEO\_PIANO FIORE NATURALE**  
*EUROPEAN BULL HIDE, NATURAL FULL GRAIN*

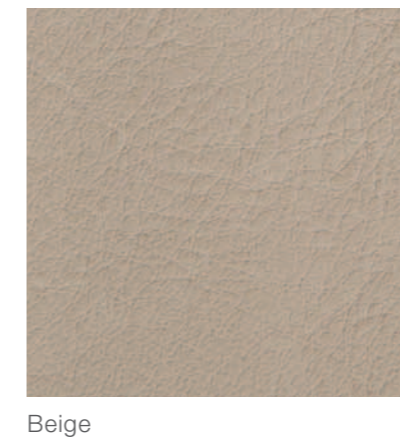

**“VOLUME 2”**

**NORMA\_TORO EUROPEO\_PIANO FIORE NATURALE**  
*EUROPEAN BULL HIDE, NATURAL FULL GRAIN*

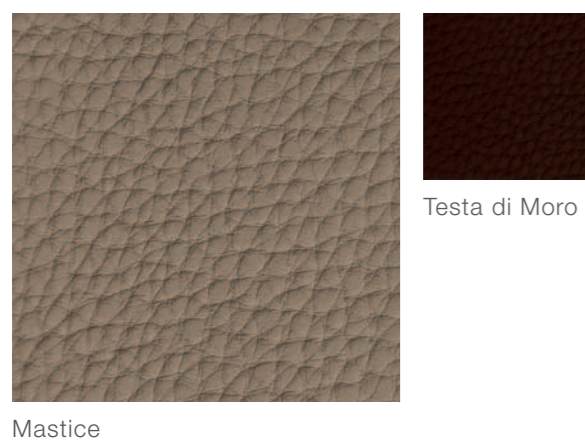

**TOSCA\_PELLE BOVINA EUROPEA\_FIORE**  
*EUROPEAN COW HIDE, GRAIN*

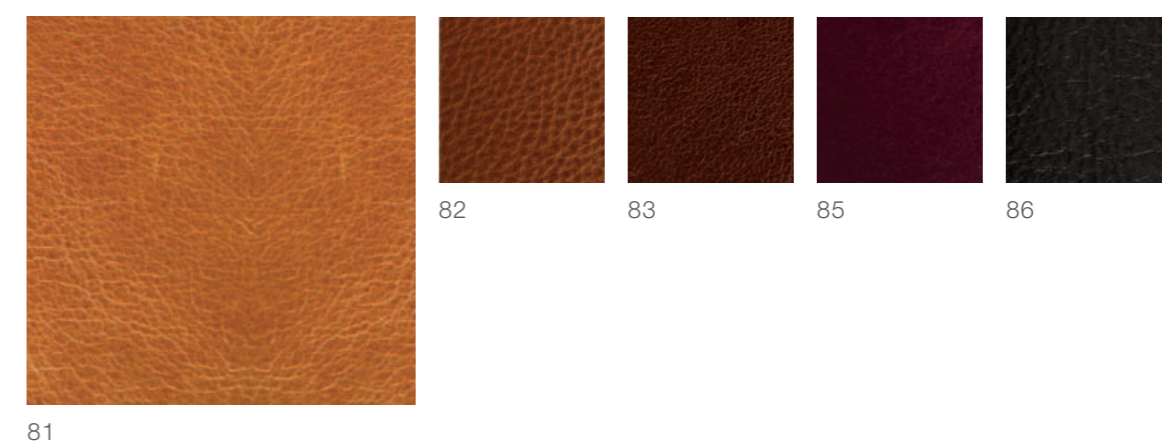

**AIDA\_PELLE BOVINA EUROPEA\_PIENO FIORE GRANA NATURALE**  
*EUROPEAN COW HIDE, FULL NATURAL GRAIN*



**CUOIO\_PELLE BOVINA EUROPEA\_PIENO FIORE**  
*LEATHER\_EUROPEAN COW HIDE, FULL GRAIN*

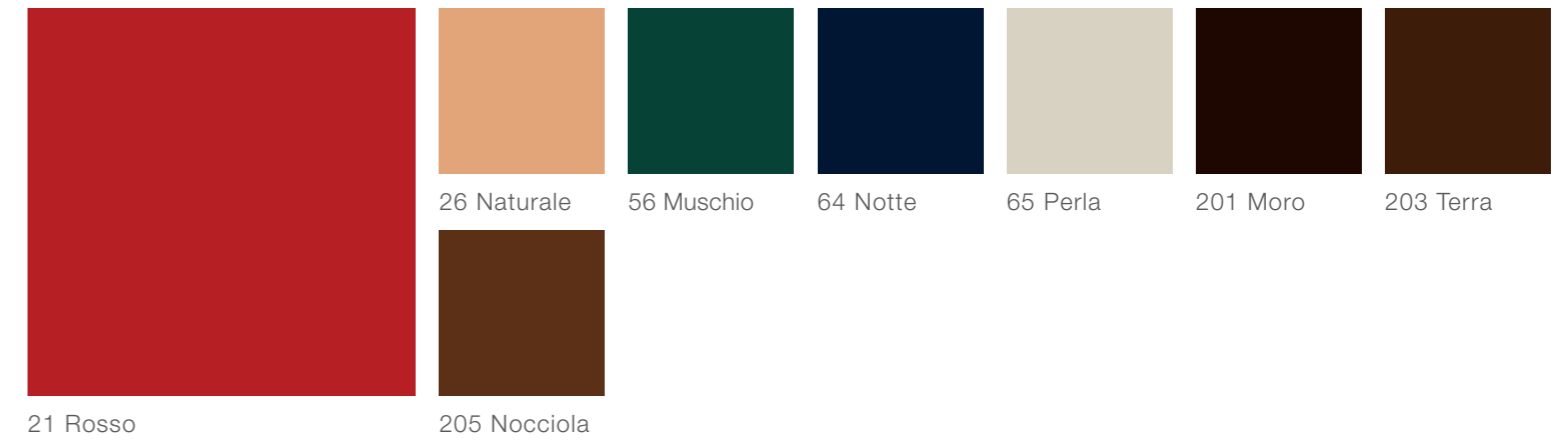

**FIDELIO\_TORO EUROPEO\_PIENO FIORE CONCIA VEGETALE**  
*EUROPEAN COW HIDE, FULL GRAIN, VEGETABLE TANNAGE*



**CARMEN\_PELLE BOVINA EUROPEA\_PIENO FIORE**  
*EUROPEAN COW HIDE, FULL GRAIN*

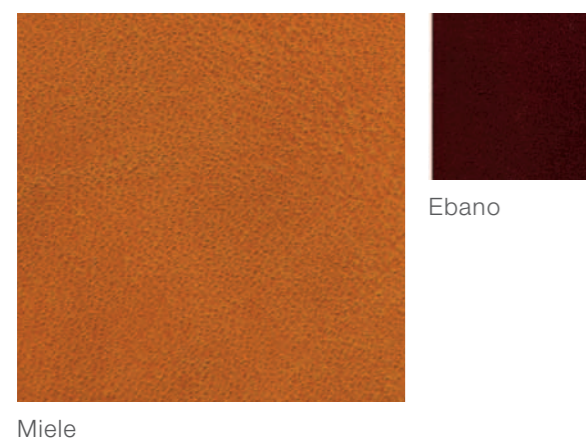

La vera pelle è un prodotto naturale; pertanto i segni e le imperfezioni che si riscontrano sulla stessa, ad esempio rughe, venature, cicatrici e spinature, oltre a differenze nel colore non sono da considerarsi difetti, bensì elementi distintivi che ne esaltano la bellezza e la contraddistinguono dalla finta pelle e da altri prodotti artificiali. Le applicazioni della pelle sono molteplici: divani, poltrone, testate per letti, borse, boiserie classiche, rivestimenti per mobili. I colori delle finiture, delle pelli e dei tessuti riportati in questo catalogo, sono suscettibili delle variazioni di stampa: fa fede il campionario dell'azienda. L'azienda si riserva di apportare in qualsiasi momento variazioni ai prodotti (di misure e di estetica) al fine di migliorarne la qualità.

*The real leather is a natural product, therefore the signs and imperfections on its surface, such as wrinkles, veins, scars and scratches as well as color differences are not to be considered defects but typical characteristics that enhance the beauty of the real leather and distinguish it from synthetic leather and other artificial products. Applications of the leathers are various: sofas, chairs, beds, bags, classic boiserie, furniture panel wall. Finishing, leather and fabric colours in the catalogue are not binding and they can be effected by printing. The company sampling only applies. The company reserves the right to modify the products (measurements and design) at any time, in order to enhance their quality.*

LUDOVICA MASCHERONI

**Unitá Produttiva**

Via Luigi Fumagalli 97/99

22066 MARIANO COMENSE (CO) ITALY

Tel. +39 031 764203

**LUDOVICA  
MASCHERONI**  
HOME ATELIER

LUDOVICA MASCHERONI

Via Luigi Cadorna 21

20821 MEDA (MB) ITALY

Tel. +39 0362 342885

[www.ludovicamascheroni.eu](http://www.ludovicamascheroni.eu)

[info@ludovicamascheroni.eu](mailto:info@ludovicamascheroni.eu)



Roberta Caglio e Fabio Mascheroni,  
AD e CEO di Ludovica Mascheroni  
“La qualità nasce dai gesti di ognuno di noi”

*Roberta Caglio and Fabio Mascheroni,  
AD e CEO Ludovica Mascheroni  
“Quality is based on our each and every  
action”*



