

MASCAGNI



SPAZIO UFFICIO

WSC

Compasso
WORKSTATION

WSC

IL MODO GIUSTO
DI PROGETTARE IL
TUO SPAZIO

THE RIGHT WAY
TO DESIGN YOUR
SPACE

INDICE

03 Define your desk
05 Prodotto, Compasso
12 Una questione di gusto
17 Design your desk
19 Finiture
21 Accessori
25 Abaco
28 Think green

03 Define your desk
05 Product, Compasso
12 It's often a matter of taste
17 Design your desk
19 Finishes
21 Accessories
25 Abacus
28 Think green

03 Define your desk
05 Prodotto, Compasso
12 Una questione di gusto
17 Design your desk
19 Finiture
21 Accessori
25 Abaco
28 Think green

WORKSTATION BY MASCAGNI ASSICURA CHE LE VOSTRE SCRIVANIE SARANNO FACILI E VELOCI DA MONTARE. IL MONTAGGIO PUÒ ESSERE ESEGUITO DA PERSONE INESPERTE IN TERMINI DI RISPARMIO DI TEMPO E DENARO.



GRANDE CAPACITÀ PRODUTTIVA
CONSULENZA E PROGETTAZIONE
SOLUZIONI SU MISURA
10.000 ARTICOLI A LISTINO
UNA STORIA CHE CONTINUA

ITALIAN DESIGN
— SINCE 1930 —

WORKSTATION BY MASCAGNI grants that your desks will be an easy and fast assemble. They can be fitted on site by unexperienced fitters, still saving time and money in the process.

A GREAT PRODUCTION CAPACITY
CONSULTANCY AND DESIGN
BESPOKE SOLUTIONS
A CATALOGUE WITH OVER 10,000 ARTICLES
A STORY THAT CONTINUES

WORKSTATION par MASCAGNI assure un montage rapide et facile de vos bureaux. L'assemblage peut être réalisé sur site même par des monteurs inexperts, sans renoncer aux gains de temps et aux économies du montage

GRANDE CAPACITÉ DE PRODUCTION
CONSEIL ET DESIGN
SOLUTIONS SUR MESURE
10.000 ARTICLES AU CATALOGUE
UNE HISTOIRE QUI CONTINUE

...DESIGN, BENESSERE, COMODITÀ, EFFICIENZA ED INVESTIMENTO.

Quando progettiamo nuovi prodotti, abbiamo chiare le tue priorità:

- .1 Benessere e comodità: questi sono i fattori primari.
- .2 L'inefficienza è un costo. È importante avere posti di lavoro efficienti.
- .3 Design, il bello piace a tutti, per noi è fondamentale che l'arredo sia coordinato con il brand ed il posizionamento dell'azienda.
- .4 Investimento, l'arredo è un bene strumentale e per questo deve essere visto come un investimento e non come un costo.

PROGETTA IL TUO SPAZIO

DESIGNING YOUR SPACE

...DESIGN, WELLNESS, COMFORT, EFFICIENCY AND INVESTMENT. When creating a new product, your priorities are very clear to us:

- .1 Well-being and comfort: these are the primary factors.
- .2 Inefficiency is a cost. It is important to have efficient workstations
- .3 Design, everybody likes the beauty, for us it is fundamental that the furniture is coordinated with the brand and the positioning of your Company.
- .4 Investments, furniture is a company asset hence it should be seen as an investment and not as a cost.

CONCEVOIR VOTRE ESPACE

...DESIGN, BIEN-ÊTRE, CONFORT, EFFICACITÉ ET INVESTISSEMENT. Lorsque nous concevons de nouveaux produits, nos priorités sont très claires:

- .1 Bien-être et confort: tels sont les facteurs principaux.
- .2 L'inefficacité est un coût. Il est important d'avoir des postes de travail efficaces.
- .3 Le design, tout le monde aime la beauté. Pour nous, il est fondamental que le mobilier soit coordonné avec la marque et le positionnement de votre entreprise.
- .4 Investissement, le mobilier est un bien d'investissement. Il est donc essentiel qu'on le considère comme tel et non pas comme un coût.

LA GIUSTA SCRIVANIA PER IL TUO UFFICIO INGREDIENTI CHE ESALTANO IL LAVORO QUOTIDIANO

Il lavoro in ufficio è responsabilità, creatività, direzione, operatività, rispetto dei compiti. L'arredo diventa uno strumento fondamentale per organizzare il lavoro di chi vi opera in termini di efficienza e benessere. In questo catalogo, oltre a soddisfare le tue esigenze estetiche, puoi trovare numerose ed uniche soluzioni che migliorano la tua quotidianità e quella dei tuoi collaboratori.

DEFINE YOUR DESK

Il percorso che porta a trovare il prodotto giusto necessita di un'analisi attenta che porta, ingrediente dopo ingrediente, a trovare il risultato ottimale.



DEFINE YOUR DESK The path that leads to finding the right product requires a careful analysis, guiding you, ingredient after ingredient, to find an optimal result.

THE RIGHT DESK FOR YOUR OFFICE

INGREDIENTS THAT ENHANCE THE DAILY WORK Work at the office is responsibility, creativity, management, operative tasks, respect for tasks. Furniture becomes a fundamental tool to organize the work of those acting there, in terms of efficiency and well-being. In this brochure, besides satisfying your aesthetic needs, you will find numerous and unique solutions that improve your everyday life and that of your co-workers.

DEFINIR VOTRE BUREAU Le chemin qui mène à la recherche du bon produit nécessite d'une analyse minutieuse qui conduit, ingrédient après ingrédient, à trouver le résultat optimal.

LE BUREAU IDÉAL POUR VOTRE PLATEAU

DES INGRÉDIENTS QUI AMÉLIORENT LE TRAVAIL QUOTIDIEN Le travail au bureau est synonyme de responsabilité, de créativité, de direction, de fonctionnement, de respect des tâches. Le mobilier devient un outil fondamental pour organiser le travail des opérateurs affectés, en termes d'efficacité et de bien-être. Dans ce catalogue, outre à satisfaire vos besoins esthétiques, vous pouvez trouver de nombreuses solutions uniques pour améliorer votre vie quotidienne et celle de vos collaborateurs.

LA GIUSTA SCRIVANIA PER UN UTENTE ESSENZIALE E MAI BANALE.
PER CHI RICERCA UN DESIGN MODERNO E DURATURO NEL TEMPO.
OGNI POSTO DI LAVORO DEVE ESSERE VISTO COME UN INVESTIMENTO E NON COME UN COSTO.



DESIGNER

MASCAGNI Spa
Pietro Mascagni, architetto

WORKSTATION COMPASSO

**DESIGN E FUNZIONALITÀ.
L'ESTETICA SI FONDE
CON L'OPERATIVITÀ.**

CARATTERISTICHE PRINCIPALI DELLA SCRIVANIA

11 finiture melaminico
5 finiture legno
2 finiture cristallo satinato
6 finiture cristallo lucido
2 finiture gambe in metallo
1 finitura gamba in legno
spessore top mm. 12-16-20-30
sezione gamba in metallo e legno cm. 7x2 rettangolare



THE RIGHT DESK FOR AN ESSENTIAL USER THAT IS NEVER PREDICTABLE. FOR THOSE LOOKING FOR A MODERN AND EVERGREEN DESIGN. EVERY WORK PLACE MUST BE SEEN AS AN INVESTMENT AND NOT AS A COST.

MAIN FEATURES OF THE DESK.

11 melamine finishes - 5 veneer finishes - 2 finitions cristal satiné - 6 finitions en cristal brillant - 2 metal legs finishes - 1 wooden leg finish- top thickness 12, 16, 20, 30 mm - metal leg section cm. 7x2 rectangular

LE BUREAU IDÉAL POUR UN UTILISATEUR ESSENTIEL ET JAMAIS BANAL. POUR CEUX QUI CHERCHENT UN DESIGN MODERNE ET DURABLE. CHAQUE LIEU DE TRAVAIL DOIT ÊTRE CONSIDÉRÉ COMME UN INVESTISSEMENT ET NON COMME UN COÛT.

CARACTÉRISTIQUES PRINCIPALES DU BUREAU.

11 finitions mélamine - 5 finitions en placage bois - 2 finitions cristal satiné - 6 finitions en cristal brillant - 2 finitions en métal et 1 en bois sur Plateaux d'épaisseur mm 12, 16, 20, 30 - Piètements en metal de section rectangulaires cm. 7x2

FLESSIBILE

Un programma di postazioni di lavoro componibili e modulabili, che si articola su differenti soluzioni per l'arredo dello spazio ufficio. Consente postazioni compatte con piani multipli e condivisi ma anche allestimenti più tradizionali formati da postazioni singole che si inseriscono perfettamente anche in ambiente domestico.



FLEXIBILITY

A collection of modular and interchangeable workstations available in many solutions for the furnishing of the office space. The program allows for compact workstations with multiple and shared tops but also for more conventional workstations that can also adapt to home working.

FLEXIBILITE

Un programme de postes de travail modulaires et interchangeables, qui s'articule en solutions multiples pour l'aménagement du bureau. Il prévoit des postes de travail compacts avec des plateaux multiples et partagés, mais aussi de des installations plus simples, de type individuel, d'adaptant aussi à un environnement de travail habitat.

VERSATILE

Uno spazio operativo pensato con le giuste scrivanie, anche con molti addetti, resta un layout semplice da interpretare utilizzando le infinite combinazioni del sistema.



VERSATILE

A workspace conceived with the right desks, even with many employees, remains a simple layout to interpret when using the infinite combinations allowed by the system.

POLYVALENTE

Un espace de travail conçu avec les bons bureaux, même en présence de nombreux employés. Un exercice d'exécution facile grâce aux combinaisons infinies au système.

ESCLUSIVO

Ogni posto di lavoro può essere reso unico con le infinite possibilità di personalizzazione offerte. Accessori modulari, schermature e contenitori di differente capacità rendono il prodotto versatile e comprensibile.



EXCLUSIVE

Each workplace can be made unique thanks to the many possibilities of customization. Modular accessories, shields and containers of different sizes make the product versatile and configurable.

EXCLUSIF

Chaque poste de travail devient unique grâce aux possibilités de personnalisation qu'offre le produit. Les accessoires modulaires, les écrans et les rangements de volumes différents rendent le produit polyvalent et configurable.



contenitore sottopiano con chiave
undermount drawer with key | tiroir encastré avec clé



mobile ausiliario con porte scorrevoli per scrivania
auxiliary desk cabinet with sliding doors | meuble auxiliaire avec portes coulissantes



portadocumenti e portaoggetti in metallo verniciato
document holder and object holder in painted metal | porte-
documents et porte-objets en métal peint

ACCESSORIABILE

I piani scrivania sono disponibili in versione singola o condivisa, sia frontalmente che lateralmente. Accessoriabili con allunghi laterali, schermi frontali, contenitori o gestione cavi, sia sotto che sopra la scrivania, assicura ampia libertà decisionale in fase di progettazione e d'uso.



SEVERAL ACCESSORIES

The desk tops are available in single or shared versions, front to front or side by side. They can be fitted with extensions returns, front screens, storage boxes, cable management, below or above the desktop, all to ensure the broadest freedom when designing and using the workspace.

NOMBREUX ACCESSOIRES

Les plans de travail sont disponibles en versions simple ou partagée, vis-à-vis ou côte-à-côte. Ils peuvent être complétés par des retours, des rangements, un système de câblage au-dessus ou au-dessous du plateau, le tout pour assurer la liberté maximale lors du projet et de l'emploi du poste de travail.

WORKSTATION BY MASCAGNI PENSA A TUTTE QUELLE CHE POTREBBERO ESSERE LE VOSTRE NECESSITÀ IN TERMINI DI ESTETICA E FUNZIONALITÀ, RISOLVENDO IN MODO CREATIVO E GRADEVOLE OGNI BISOGNO.



B - HB BIANCO | WHITE | BLANC



G - HI ANTRACITE | ANTHRACITE | ANTHRACITE



WB LEGNO FAGGIO - BIANCO | WOOD BEECH - WHITE
| HÊTRE BOIS - BLANC
B - HB BIANCO | WHITE | BLANC

**SPESSE È UNA
QUESTIONE DI GUSTO**



IT'S OFTEN A MATTER OF TASTE
WORKSTATION BY MASCAGNI thinks at all those needs that you may have in terms of aesthetics and functionality, bringing a creative and pleasant solution to every need.

C'EST SOUVENT UNE QUESTION DE GOÛT
WORKSTATION DE MASCAGNI pense à tous ceux que peuvent être vos besoins en termes d'esthétique et de fonctionnalité et vous apporte une solution créative et agréable pour chacune de vos exigences.



ECLETTICO

Progettare scrivanie per ufficio che abbiano come obiettivo principale quello di rendere migliore il lavoro in ufficio in termini di benessere ed efficienza.
Le persone hanno esigenze diverse: mansioni, responsabilità, metodi di lavoro. Offrire la giusta soluzione in termini di posto di lavoro è la nostra mission.

ECLECTIC
Designing office desks that aim at making better your work at office in terms of well-being and efficiency. People have different needs: tasks, responsibilities, working methods. Our mission is to offer the right solution as a work place.

ÉCLECTIQUE
Concevoir des bureaux qui aient comme objectif principal celui d'améliorer le travail au bureau en termes de bien-être et d'efficacité.
Les gens ont des besoins différents: tâches, responsabilités, méthodes de travail. Notre mission est d'offrir les bonnes solutions en termes d'espace de travail.

WORKSTATION BY MASCAGNI VI ASSICURA CHE LE VOSTRE SCRIVANIE SARANNO FACILI E VELOCI DA MONTARE. IL MONTAGGIO PUÒ ESSERE ESEGUITO DA PERSONE INESPERTE IN TERMINI DI RISPARMIO DI TEMPO E DENARO.



WORKSTATION BY MASCAGNI ensures you that your desks will be easy and fast to assemble. The assembly can be carried out by unexperienced fitters, yet saving time and money while fitting.

WORKSTATION DE MASCAGNI vous assure que vos bureaux seront faciles et rapides à assembler. l'assemblage peut être effectué par des personnes inexpertes tout en gagnant du temps et de l'argent.



ELEGANTE

Il giusto equilibrio di forme e colori fa la differenza nel momento in cui l'oggetto viene inserito nel suo contesto. Trovare l'equilibrio tra volume e sfumatura è ciò che rende un progetto accurato, anche in fase d'uso.

ELEGANT
The right balance of shapes and colors makes the difference when the object occupies its place in its environment. Finding that balance between volume and nuance is what makes a project accurate, as its daily use.

ELEGANT
Le bon équilibre des formes et des couleurs fait la différence lorsque l'objet est inséré dans son contexte. Trouver cet équilibre entre volume et nuance est ce qui rend un projet soigné, même pendant son emploi quotidien.

DESIGN YOUR DESK

Il sistema strutturale di Workstation e' versatile e intuitivo, le componenti principali del prodotto restano invariate quando, come possibilità, è possibile disegnare o scegliere la propria gamba o struttura verticale fino a renderla unica e progettata a misura.

PIANI IN CRISTALLO EXTRACHIARO | Glass Extra-clear tops | Dessus en cristal extraclair



LUCIDI RETROVERNICIATI | BACK-PAINTED POLISHES | VERNIE AU DOS POLIS

RETROVERNICIATI SATINATO | BACK-PAINTED SATINISED | VERNIE AU DOS SATINE



I piani scrivania di Workstation, in nobilitato o legno, possono essere scelti indifferentemente tra gli spessori 16, 20 e 30 mm.

I piani in cristallo extrachiario, lucidi o satinati, retrovernicati, sono di spessore 12 mm. La struttura non cambia, resta sempre la stessa insieme al sistema di aggancio, alle regolazioni della scrivania e agli accessori.

Workstation desk tops, in melamine or wood, can be chosen between 16, 20 and 30 mm of thickness.

The tops in extraclear, glossy or satin finished glass, back-painted, are 12 mm thickness. The structure does not change; it remains the same as the coupling system, the desk adjustments and the other accessories.

Les plateaux des postes de travail, en mélaminé ou plaqués bois, peuvent être choisis dans les épaisseurs de 16, 20 et 30 mm.

Les plateaux en verre extraclear, brillant ou satiné, laqué à l'arrière, épaisseurs 12 mm. La structure ne change pas, elle reste la même ainsi que le système de connexion, les réglages du bureau et les accessoires disponibles.

It's my desk!

DESIGN YOUR DESK

The Workstation structural system is versatile and intuitive. The main components of the product remain unchanged even when one elects to choose the legs or other vertical structures that he likes better, making it unique in its customized designed.

CONCEVEZ VOTRE BUREAU

Le système structurel du poste de travail est polyvalent et intuitif; ses composants principaux restent inchangés lorsque, comme prévu, on décide de concevoir son poste ou choisir son piètement ou sa propre structure verticale pour le rendre unique et conçu sur mesure.

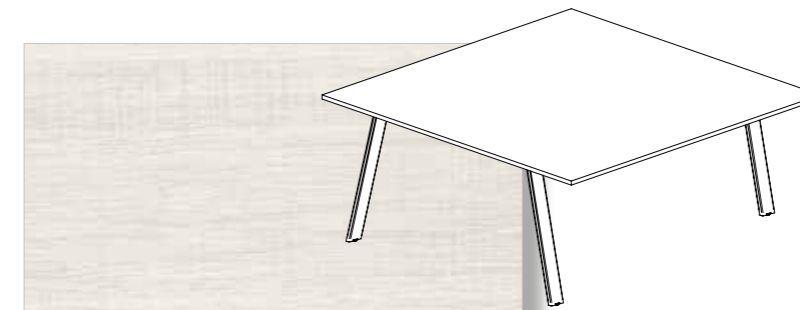

piano intero p. 60/80/100/120/160 cm.
entire top | plan complet

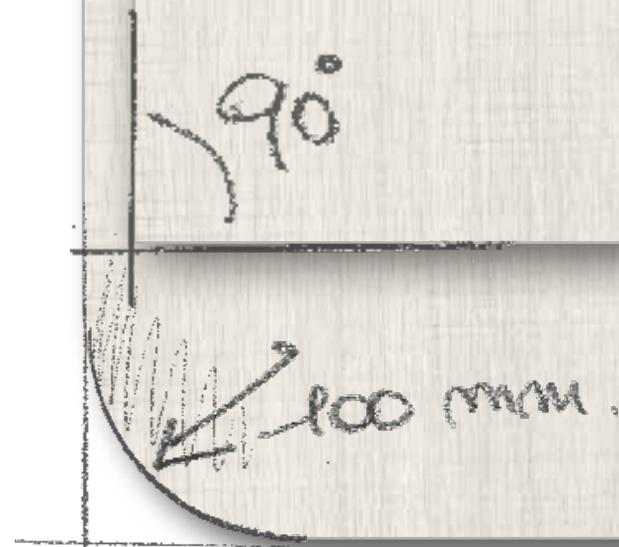

piano condiviso p. 120/160 cm.
shared top | plan partagé

piano condiviso con sportello a ribalta p. 120/160 cm.
shared top with shaped top access | plan partagé avec accès supérieur en forme

piano condiviso con sportello sagomato p. 120/160 cm.
shared top with foldable top access | plan partagé avec accès supérieur pliable

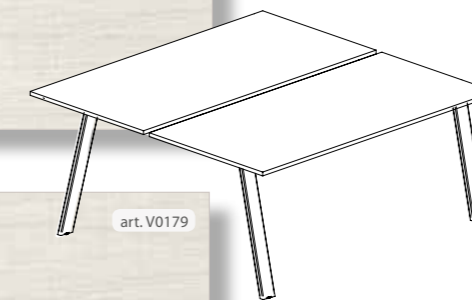

piano condiviso con passaggio cavi centrale p. 120/160 cm.
shared top with central passage and cover top access | plan partagé avec passage central et couvercle

Le scrivanie di Workstation possono essere progettate con piani squadrati o con gli spigoli arrotondati e con una grande varietà di allestimento dei piani, interi, segmentati, con top access sagomati o lineari e passaggi cavi. L'ampia libertà di configurazioni permette la massima versatilità di un prodotto che brilla per le sue caratteristiche tecniche e di design assicurando il giusto livello tecnologico per ogni specifica esigenza.

Workstation desks can be designed with squared tops or with rounded edges and a wide variety of floor plans, complete, segmented, with shaped or linear top access and cable passages. The broad choice of configurations grants the maximum versatility of a product that shines for its technical and design features and ensures the right technological level for each specific need.

Les bureaux de Workstation peuvent prévoir des plans carrés ou des coins arrondis et une grande variété de plans d'étage, complets, segmentés, avec accès supérieur ou linéaire et passages de câbles profilés ou linéaires. La grande liberté de configuration permet la polyvalence maximale d'un produit qui se distingue par ses caractéristiques techniques et son design garantit le bon niveau technologique pour chaque besoin spécifique.

STRUTTURE SCRIVANIE E MOBILI LATERALI | Desks and lateral furniture structure | Structure de meubles latéraux et bureaux



B - HB BIANCO | WHITE | BLANC
B - M1 BIANCO | WHITE | BLANC



G - H1 ANTRACITE | ANTHRACITE
G - M1 ANTRACITE | ANTHRACITE

FINITURA DELLE STRUTTURE VERTICALI DELLE SCRIVANIE | Finishing of the vertical structures of the desks | Finitions des structures verticales des bureaux



WB LEGNO FAGGIO - BIANCO | WOOD BEECH - WHITE | HÊTRE BOIS - BLANC

FINITURE

Finishes | Finitions

MELAMINICI

Melamine | Mèlamine



MR MELAMINICO QUERCIA BIANCA | MELAMINE WHITE OAK | MÉLAMINE CHÊNE BLANC



ME MELAMINICO SELVA NERA | MELAMINE BLACK FOREST | MÉLAMINE FORÊT NOIRE



ML MELAMINICO CILIEGIO SATIN | MELAMINE CHERRY SATIN | MÉLAMINE CERISIER SATIN



MH MELAMINICO OLMO SILVER | MELAMINE ELM SILVER | MÉLAMINE ORME ARGENT



MM MELAMINICO NOCE | MELAMINE WALNUT | MÉLAMINE NOYER



MG MELAMINICO TABACCO | MELAMINE TOBACCO | MÉLAMINE TABAC



MX MELAMINICO LINO | MELAMINE LINEN | MÉLAMINE LINGE



MK MELAMINICO ALLUMINIO | MELAMINE ALUMINIUM | MÉLAMINE ALUMINIUM

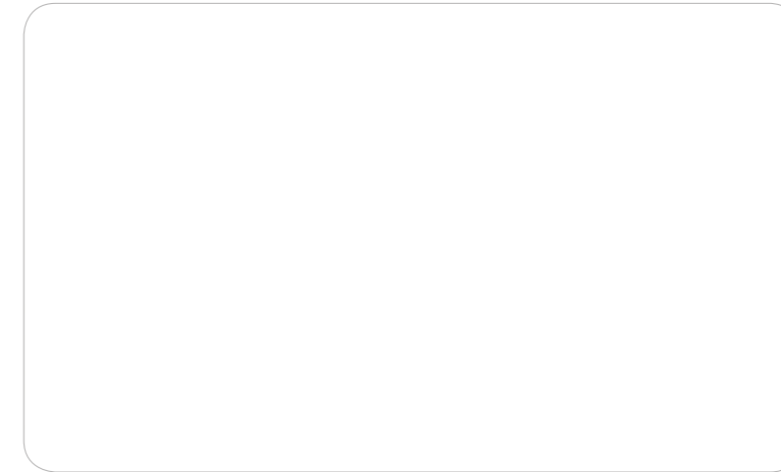

M1 MELAMINICO BIANCO RAL9016 | MELAMINE WHITE | MÉLAMINE BLANC



MV MELAMINICO VISONO | MELAMINE MINK | MÉLAMINE VISON

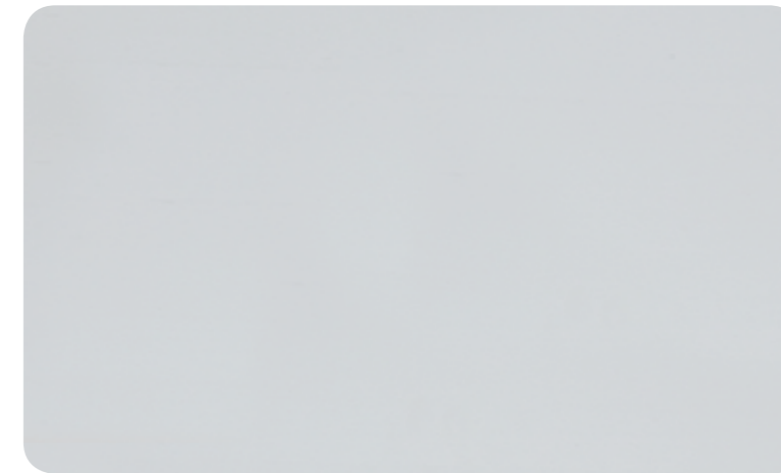

MJ MELAMINICO GRIGIO PERLA | MELAMINE PEARL GREY | MÉLAMINE GRIS



LEGNI

Wood | Finitions

WS LEGNO NOCE SATIN | WALNUT SATIN WOOD | BOIS NOYER SATIN



WA LEGNO NOCE WENGÉ | WENGE WOOD | BOIS NOYER WENGÉ



WZ LEGNO NOCE TABACCO | TOBACCO BROWN WALNUT WOOD | BOIS NOYER TABAC



WE LEGNO EBANO NERO | EBONY BLACK WOOD | BOIS D'ÉBÈNE NOIR



WU LEGNO ULIVO | OLIVE WOOD | BOIS D'OLIVIER

KIT PRESE A SCRIVANIA



art. 74

kit 3 prese Schuko+2 Dati - cavo 1,2 mt.
kit 3 Schuko+2 Data plugs with wire |
kit 3 prises Schuko+2 Dati avec cable

MULTIPRESA



art. 4452

kit 3 prese Schuko+2 Dati - cavo 1,2 mt.
kit 3 Schuko+2 Data plugs with wire |
kit 3 prises Schuko+2 Dati avec cable

SUPPORTO CAVI

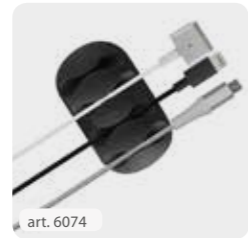

art. 6074

supporto adesivo 3 cavi
adhesive support 3 cables |
support adhésif 3 câbles

PORTA CAVI

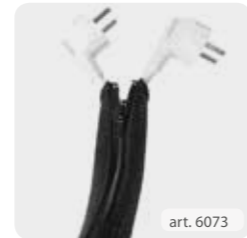

art. 6073

tasca porta cavi
cable pocket | poche pour câble

ELETTIFICABILE

Prevedere e prevenire le necessità d'uso di ciascun operatore è parte della fase progettuale che differenzia una scrivania da un luogo di lavoro efficiente.



VANO PASSACAVI



art. V0041 - V0042
art. V0045 - V0046

copertura per passaggio cavi 40 mm.
cable passage cover | couvercle de passage de câble

VANO GRANDE CAPACITÀ



art. V0050 - V0051

copertura cavi grande capacità per passaggio cavi 300 mm.
large capacity cover for cable routing | couvercle de grande capacité pour le routage des câbles

CABLABLE

Il cablaggio di un posto di lavoro deve essere differenziabile e versatile. Deve essere sempre assicurata la possibilità di rispondere a necessità specifiche di ogni utilizzatore o di ogni impresa.

PORTA COMPUTER



art. V0173

porta PC in metallo per scrivania 160x150 x H520 mm.
metal PC holder for desk | porte PC suspendu en metal

PORTA MONITOR



art. 2666
art. V0141

portamonitor per scrivania fissaggio VESA (peso max 8 kg.)
monitor holder for desk VESA | Porte-moniteur VESA pour bureau



BOTOLA PASSACAVI



art. P

passaggio cavi circolare diam. 60 mm.
circular cable passage | passage de câble circulaire

DOPPIA PRESA USB



art. 6067

doppia presa USB 70x25 mm.
double USB socket | double prise USB

CARICABATTERIE INDUZIONE



art. 6069

caricabatterie a induzione diam. 80 mm.
wireless charger | chargeur sans fil

PRESE USB CON SPORTELLO



art. 6068

modulo doppia presa USB con sportello 120x65 mm.
double USB electrical module | module double prise USB avec couvercle coulissant

TOP ACCESS CON CABLAGGIO

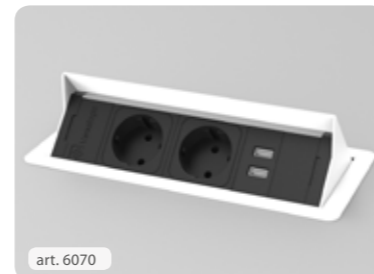

art. 6070

modulo con prese elettriche e USB 270x95 mm.
module with electrical sockets and USB | module avec prises électriques et USB couvercle coulissant

SEPARAZIONE PIANO



art. V0170

piano separato di 40 mm.
40 mm. separate top | 40 mm de sol séparé

SPORTELLA A RIBALTA



art. V0278

sportello a ribalta 400x130 mm.
foldable top access | accès supérieur pliable

SPORTELLA SAGOMATA



art. V0177
art. V0277

sportello sagomato 400x130 mm.
shaped top access | accès supérieur en forme

PASSAGGIO CAVI CENTRALE

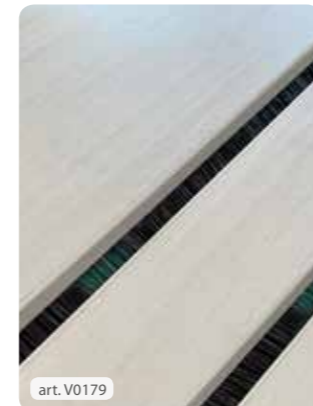

art. V0179

passaggio cavi centrale 150 mm. con copertura
central passage with cover | passage central avec couvercle

TOP ACCESS

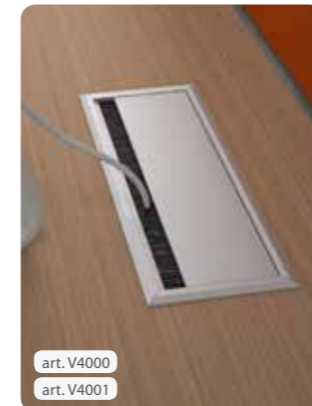

art. V4000
art. V4001

top access 200x100 mm.
top access for desk | clapet top access

POWERED

Predicting and preventing the use needs by each operator is part of the design process that makes the difference between just a desk and an efficient workstation.

ÉLECTRIFIÉ

Prévoir et prévenir les besoins d'emploi de chaque opérateur sont une part importante du processus de conception qui fait la différence entre un bureau quelconque et un poste de travail efficace.

WIREABLE

The wiring of a workplace must be differentiable and versatile. The possibility of responding to the specific needs of each of the many Office users must always be ensured.

CÂBLABLE

Le câblage d'un poste de travail doit être différentiable et polyvalent. La possibilité de répondre aux besoins spécifiques de chaque utilisateur dans l'entreprise doit toujours être garantie.

PERFORMANTE

La componibilità trasversale tra i vari accessori che allestiscono uno spazio di lavoro permettono di ottenere il massimo da ogni configurazione, che diventa allo stesso tempo unica e facilmente ripetibile con piccole modifiche per rispondere a ogni specifica necessità.

SCHERMO IN SOUND, MELAMINICO O TESSUTO



schermo frontale raggiato o squadrato sp. 16 mm.
radial or squared front screen | écran frontal radial ou carré

PANNELLO FRONTALE



pannello frontale raggiato o squadrato sp. 16 mm.
radial or squared desk modesty panel | voile de fond radial ou carré

STRUTTURA METALLICA



struttura in metallica 70X20 mm. spessore 2 mm.
disponibile in bianco B e antracite G
metal structure available in white B and anthracite G |
structure métallique disponible en blanc B et anthracite G

SUPPORTO LIGNEO



supporto in legno di faggio 70X20 mm.
beech wood support | support en bois de hêtre

ALLUNGO LATERALE CONDIVISO



top per allungo complanare 1200 mm.
top for extension at same height | plateau pour rallong. e à la même hauteur

PERFORMING

The transversal modularity between the different accessories that make a work space allows you to get the most out of every configuration, which at the same time becomes unique and easily repeatable with small modifications to meet every specific need.

PERFORMANT

La modularité transversale entre les différents accessoires constituant un espace de travail vous permet de tirer le meilleur parti de chaque configuration, qui devient ainsi unique et facilement reproduisible avec de moindres modifications pour répondre à chaque besoin spécifique.

CASSETTO SOTTO PIANO



contenitore sottopiano con chiave 420x61x550 mm.
undermount drawer with key | tiroir encastré avec clé

CONTENITORE SCRIVANIA



mobile ausiliario con porte scorrevoli per scrivania 700x250x350 mm.
auxiliary desk cabinet with sliding doors | meuble auxiliaire avec portes coulissantes

SCHERMO METACRILATO



divisorio frontale in metacrilato sp. 8 mm.
methacrylate frontal screen | panneau de séparation en méthacrylate

XM METACRILATO FUMÈ | METHACRIL. BLACK | METHACRIL. FUMÈ

XW METACRILATO OPALINO | METHACRIL. OPAL | METHACRIL. OPALINE

CHANGING

Accessories help make your workplace unique, customizable in any of its characteristics, be it of use or color. Having everything at hand turns a desk into an effective work tool.

CHANGEANT

Les accessoires rendent votre poste de travail unique, personnalisable dans chacune de ses caractéristiques, d'emploi ou de couleur. Avoir tout sous la main transforme un bureau en un outil de travail efficace.

MUTEVOLE

Gli accessori aiutano a rendere unico il proprio luogo di lavoro, personalizzabile in ogni sua caratteristica, sia essa d'uso o di colore. Avere tutto a portata di mano trasforma una scrivania in uno strumento di lavoro efficace.

CASSETTIERA LATERALE



cassettiera con cassetti e guide in metallo con chiusura ammortizzata 440x500x440 mm.
set of drawers with drawers and guides in metal with soft closing |
caisson avec tiroirs et guides en métal à fermeture en douceur portes coulissantes

Il mobile laterale è disponibile in 4 versioni. Le strutture possono essere ordinate in bianco, argento o antracite, oppure tutto in una unica finitura, uguale ai top e alle ante.
| the side cabinet is available in 4 versions. The structures can be ordered in white, silver or anthracite, or all in a single finish, the same as the tops and doors. | l'armoire latérale est disponible en 4 versions. Les structures peuvent être commandées en blanc, argent ou anthracite, ou toutes en une seule finition, comme les dessus et les portes.

DISPONIBILE ANCHE CON ANGOLI RAGGIATI
ALSO AVAILABLE WITH SPOKED CORNERS
AUSSI DISPONIBLE AVEC COINS ARRONDIE

DISPONIBILE IN CRISTALLO EXTRACHIARO
AVAILABLE IN EXTRA-CLEAR TOPS
DISPONIBILE EN CRISTAL EXTRACLAIR

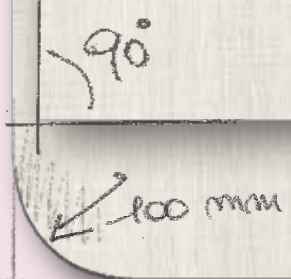

SCRIVANIE SINGOLE
DESKS | BUREAUX

□ **POSTAZIONE SINGOLA**
Single workstation |
Poste de travail unique

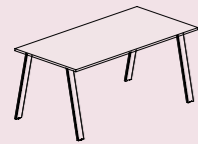

L 80/100/120/140/160/180/200
P 80/100 - H 74

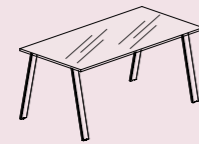

○ L 160/180/200 - P 100 - H 74

□ **POSTAZIONE DOPPIA**
Double workstation |
Double poste de travail

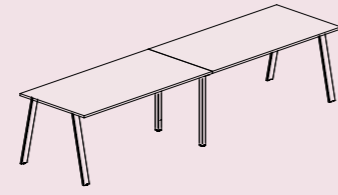

L 120/160/200/240/280/320/360/400
P 80/100 - H 74

□ **POSTAZIONE AGGIUNTIVA**
Additional work station | Poste de
travail supplémentaire

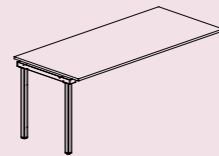

L 80/100/120/140/160/180/200
P 80/100 - H 74

□ **POSTAZIONE SINGOLA CON CONTENITORE DI SUPPORTO**
Single workstation with support container |
Poste de travail unique avec conteneur de support

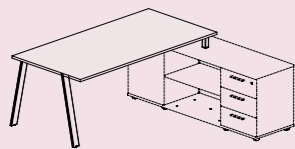

L 80/100/120/140/160/180/200
P 80/100 - H 74
○ L 160/180/200 - P 100 - H 74

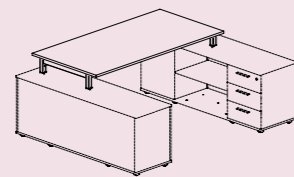

□ **POSTAZIONE AGGIUNTIVA**
Additional work station | Poste de
travail supplémentaire

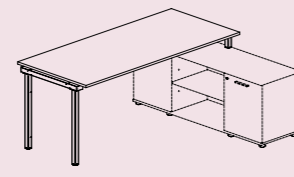

L 60/80/100/120/140/160/180/200
P 80/100 - H 74

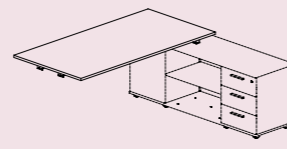

SCRIVANIE CONDIVISE
SHARED DESKS | BUREAUX PARTAGÉ

□ **POSTAZIONE CONDIVISA**
Shared work station |
Poste de travail partagé

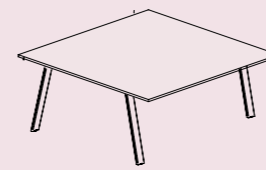

L 120/140/160/180/200
P 120/160 - H 74

□ **POSTAZIONE DOPPIA**
Double workstation |
Double poste de travail

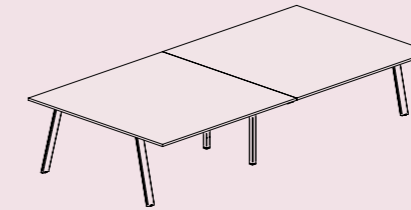

L 240/280/320/360/400
P 120/160 - H 74

□ **POSTAZIONE AGGIUNTIVA**
Additional work station | Poste de
travail supplémentaire

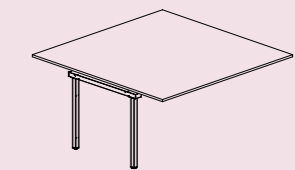

L 120/140/160/180/200
P 120/160 - H 74

□ **POSTAZIONE CONDIVISA CON CONTENITORE DI SUPPORTO**
Shared workstation with support container |
Poste de travail partagé avec conteneur de support

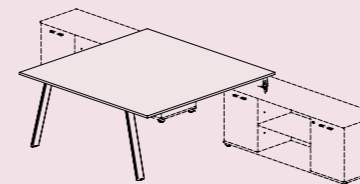

L 120/140/160/180/200
P 120/160 - H 74

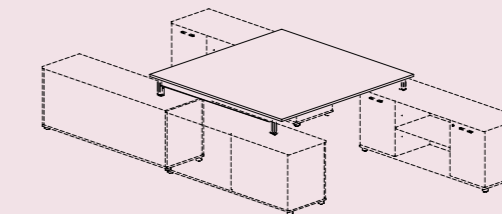

□ **POSTAZIONE AGGIUNTIVA**
Additional work station | Poste de
travail supplémentaire

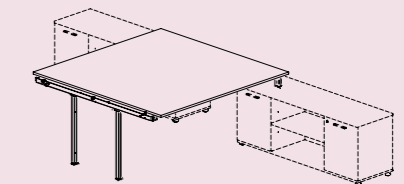

ACCESSORI PER SCRIVANIE SINGOLE

ACCESSORIES FOR SINGLE DESKS | ACCESSOIRES POUR BUREAUX UNIQUES

□ **ALLUNGHI LATERALI PER SCRIVANIA**
Lateral layers for desk | Couches latérales
pour bureau

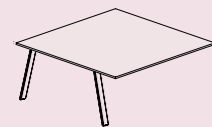

P 120 - H 74
L 80/100/120/140/160/180

□ **COPERTURA SUPPORTI**
support cover | couverture
pour support

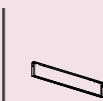

L 80/100

□ **ACCESSORI AUSILIARI SCRIVANIA SINGOLA**
Auxiliary accessories for single desk |
Accessoires auxiliaires pour bureau unique

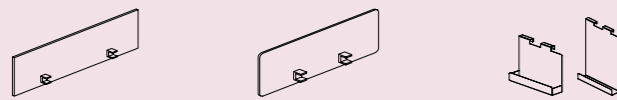

L 60/80/100/120/140/160/180 L 60/80/100/120/140/160/180 L 21 - H 15 L 21 - H 30
H 40 H 40 - R 10

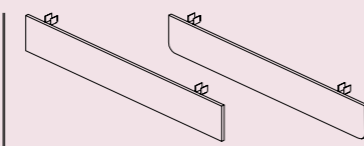

L 60/80/100/120/140/160/180/200
H 25 & H25 - R10

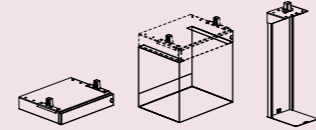

L 42 - P 32 L 42 - P 32 L 16 - P 15
H 5 H 32 H 51

ACCESSORI PER SCRIVANIE CONDIVISE

ACCESSORIES FOR SHARED DESKS | ACCESSOIRES POUR BUREAUX PARTAGÉ

□ **ALLUNGHI LATERALI PER SCRIVANIA**
Lateral layers for desk | Couches
latérales pour bureau

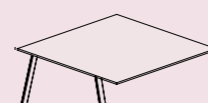

P 120 - H 74
L 80/100/120/140/160/180

□ **COPERTURA SUPPORTI**
support cover | couverture
pour support



L 120/160

□ **ACCESSORI AUSILIARI SCRIVANIA CONDIVISA**
Auxiliary accessories for shared desk |
Accessoires auxiliaires pour bureau partagé

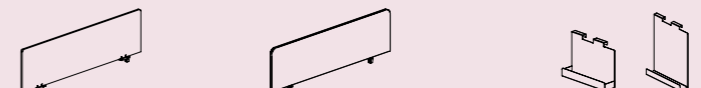

L 60/80/100/120/140/160/180 L 60/80/100/120/140/160/180 L 21 - H 15 L 21 - H 30
H 40 H 40 - R 10

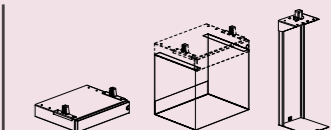

L 42 - P 32 L 42 - P 32 L 16 - P 15
H 5 H 32 H 51

ELETTRIFICAZIONE PER SCRIVANIE SINGOLE

ELECTRIFICATION FOR SINGLE DESKS | ELECTRIFICATION POUR BUREAUX UNIQUES



L 30/50/70/90/110/130/150/170 L 50/90/130 L 60/80/100/120/140/160/180/200 L 20 - P 10 L 28 - P 6
P 13 H 11 P 10 P 2 H 5

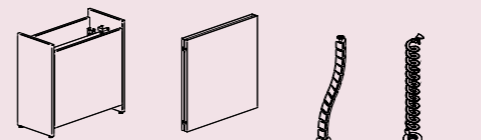

L 30 - P 30 L 4 - P 30 L 8 - H 71 Ø 10 - H 110
L 30 - P 60 L 4 - P 60

ELETTRIFICAZIONE PER SCRIVANIE CONDIVISE

ELECTRIFICATION FOR SHARED DESKS | ELECTRIFICATION POUR BUREAUX PARTAGÉ



L 30/50/70/90/110/130/150/170 L 50/90/130 L 60/80/100/120/140/160/180/200 L 20 - P 10 L 28 - P 6
P 30 - H 11 P 30 P 2 H 5

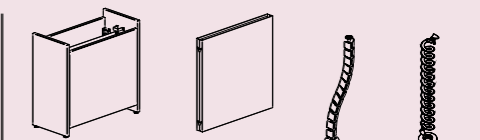

L 30 - P 30 L 4 - P 30 L 8 - H 71 Ø 10 - H 110
L 30 - P 60 L 4 - P 60

ABACO PIANI RIUNIONE | ABACUS OF THE MEETING TABLES | ABAQUE DES TABLES DE RÉUNION

DISPONIBILE ANCHE CON ANGOLI RAGGIATI
ALSO AVAILABLE WITH SPOKED CORNERS
AUSSI DISPONIBLE AVEC COINS ARRONDIE

DISPONIBILE IN CRISTALLO EXTRACHIARO
AVAILABLE IN EXTRA-CLEAR TOPS
DISPONIBLE EN CRISTAL EXTRACLAIR

TAVOLI RIUNIONE
CONFERENCE TABLE | TABLES DE REUNIONS

TAVOLI RETTANGOLARI
Rectangular tables |
Tables rectangulaires

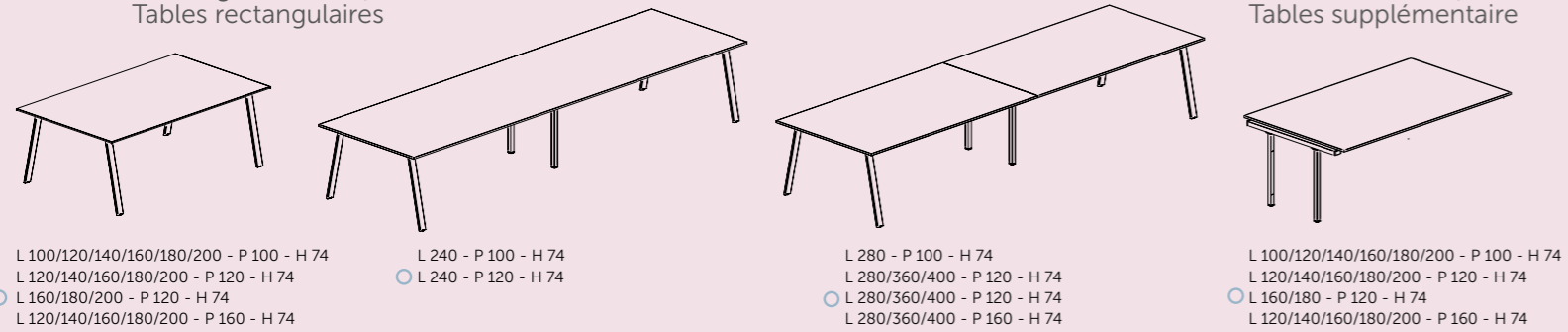

TAVOLI AGGIUNTIVI
Additional tables |
Tables supplémentaire

TAVOLI SAGOMATI, CIRCOLARI E A BOTTE
Shaped tables, circular and barrel |
Tables en forme, circulaire et tonneau

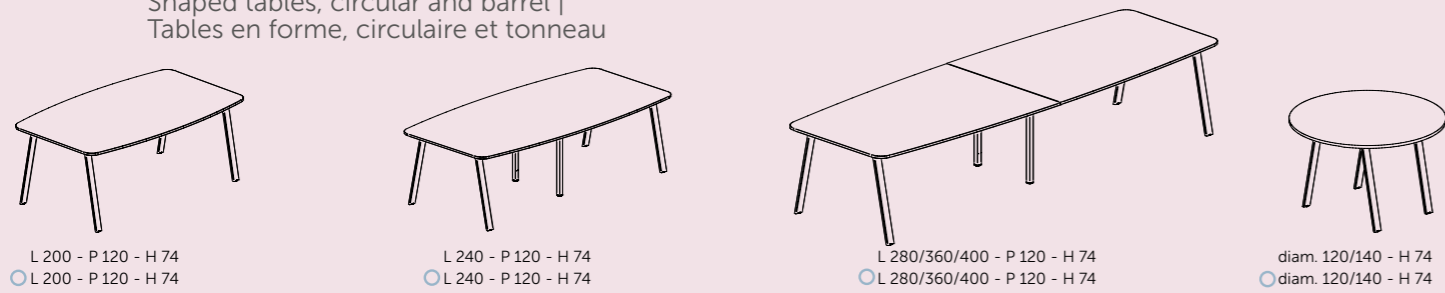

ELETRIFICAZIONE PER TAVOLI RIUNIONE
ELECTRIFICATION FOR CONFERENCE TABLE | ELECTRIFICATION POUR TABLES DE REUNIONS

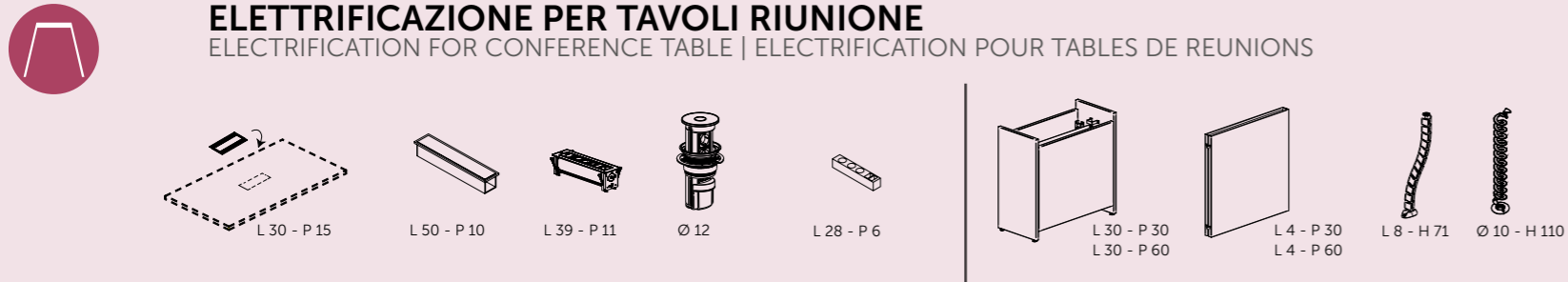

MULTIPRESA ACCESSO CAVI



kit 3 prese Schuko+2 Dati - cavo 1,2 mt.
kit 3 Schuko+2 Data plugs with wire |
kit 3 prises Schuko+2 Dati avec cable

kit 3 prese Schuko+2 USB - cavo 1,2 mt.
kit 3 Schuko+2 USB plugs with wire |
kit 3 prises Schuko+2 USB avec cable

ACCESSO CAVI BILATERALE



accesso cavi due lati in finitura - 500x100 mm.
top access in finish with cable access 2 sides |
accès supérieur en finition avec 2 accès par câble

ACCESSO CAVI CON CHIUSURA



top access per tavolo riunioni colore alluminio - 500x100 mm.
access top for conference table aluminum color |
clapet central pour table réunions couleur aluminium

ELETRIFICAZIONE A SCOMPARSA



kit 3 prese Schuko + 2 USB - cavo 1,2 mt. - 390x110 mm.
kit 3 Schuko + 2 USB plugs with wire | kit 3 prises Schuko + 2 USB avec cable

TORRETTA ESTRAIBILE



kit 2 prese Schuko + 2 USB - cavo 1,2 mt. - Ø 120 mm.
kit 2 Schuko + 2 USB plugs with wire |
kit 2 prises Schuko + 2 USB avec cable

ABACO CONTENITORI | ABACUS OF CONTAINERS | ABAQUE DE CONTENEURS

CONTENITORI E CASSETTIERE
CONTAINERS AND DRAWERS | CONTENEURS ET TIROIRS

CONTENITORI A SUPPORTO SCRIVANIA
Desk support containers |
Conteneurs de support de bureau

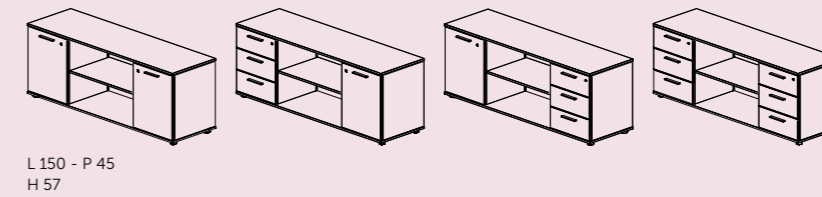

CASSETTIERE E MOBILETTI
Drawers and furniture |
Tiroirs et meubles

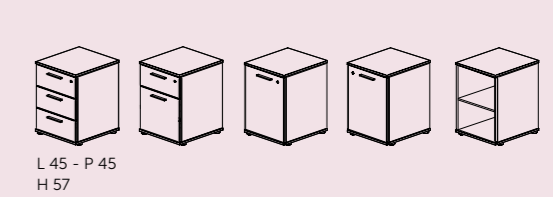

CONTENITORI SU RUOTE
Containers on wheels | Conteneurs sur roues

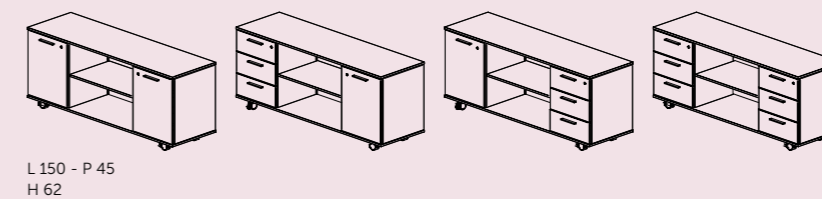

CASSETTIERE E MOBILETTI SU RUOTE
Drawers and furniture on wheels | Tiroirs et meubles sur roues

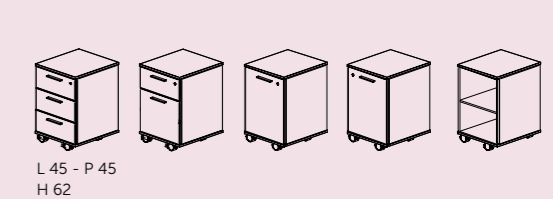

CONTENITORI PER SCRIVANIA
Containers for desk |
Conteneurs pour bureau

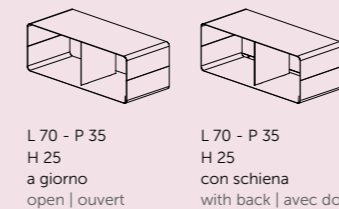

CONTENITORI ANTE SCORREVOLI
Sliding door containers | Contenant
porte coulissante

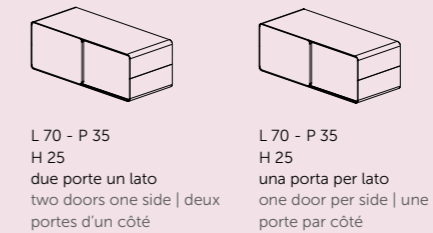

CASSETTIERE IN METALLO
Metal drawers | Tiroirs métalliques

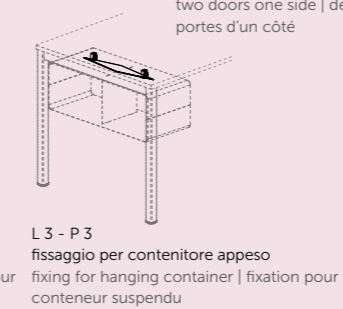
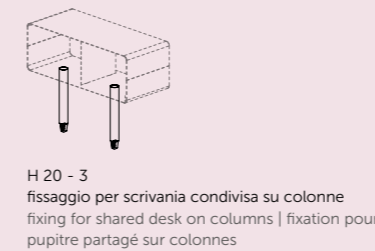
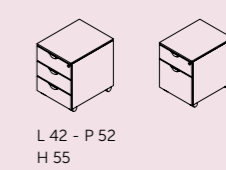

CONTENITORE ANTA SCORREVOLE



CONTENITORE CONDIVISO SU COLONNE



CONTENITORE APPESO



THINK GREEN



IL PROCESSO DI SVILUPPO DI MASCAGNI TIENE CONTO DELL'IMPATTO AMBIENTALE IN TUTTE LE FASI DEL CICLO DI VITA DEL PRODOTTO: DALLA SELEZIONE DELLE MATERIE PRIME, FINO AL RIUTILIZZO E AL RICICLO DEI MATERIALI.

THE MASCAGNI DEVELOPMENT PROCESS KEEPS INTO ACCOUNT THE ENVIRONMENTAL IMPACT IN ALL THE PHASES OF THE LIFE CYCLE OF PRODUCT: STARTING FROM THE SELECTION OF RAW MATERIALS, TO THE RE-USE AND THE RECYCLING OF MATERIALS.

LE PROCESSUS DE DÉVELOPPEMENT DE MASCAGNI CONSIDÈRE L'IMPACT SUR L'ENVIRONNEMENT DANS TOUS LES STADES DU CYCLE DE VIE DU PRODUIT: À PARTIR DE LA SÉLECTION DES MATÉRIAUX JUSQU'À LA RÉUTILISATION ET AU RECYCLAGE DES MATÉRIAUX.



RICICLO WORKSTATION, modulare e facile da smontare con normali attrezzi di uso comune. Alla fine del suo ciclo di vita ogni suo componente sarà facilmente riciclabile

RECYCLING WORKSTATION has a modular structure and it is easy to disassemble with regular, everyday tools. At the end of its life cycle, every single component can be easily recycled.

RECYCLE WORKSTATION, modulaire et facile à démonter à l'aide d'outils d'usage courant. À la fin de son cycle de vie, chacun de ses composants sera facilement recyclable.



UTILIZZO Le emissioni di formaldeide, dei materiali utilizzati, sono ampiamente all'interno dei limiti di sicurezza imposti dalla normativa E1 (EN13986).

USE The formaldehyde emissions coming from the materials used are widely within the security limits set by EN13986.

UTILISATION Les émissions de formaldéhyde des matériaux utilisés sont largement au sein des limites de sécurité imposées par la norme E1 (EN13986).



TRASPORTO Siamo attenti a ridurre il peso e volume dell'imballaggio in modo da ottimizzare il tasso di riempimento dei mezzi di trasporto. In questo modo utilizziamo meno carburante ed energia per le consegne.

TRANSPORT We pay particular attention to reducing the weight and the volume of the packaging so that our means of transport are as full as possible. In this way we use less fuel and less energy for our deliveries.

TRANSPORT Nous faisons attention à réduire le poids et le volume des emballages pour optimiser le taux de remplissage des moyens de transport. De cette façon, nous utilisons moins de carburant et d'énergie pour les livraisons.



MATERIALI WORKSTATION non contiene materiali nocivi. I pannelli di legno utilizzati per la produzione sono certificati FSC (legno proveniente da foreste gestite in maniera corretta e responsabile).

MATERIALS WORKSTATION uses no harmful materials. The wood panels used for production are FSC certified (wood coming from forests handled in the correct and sustainable way).

MATÉRIAUX WORKSTATION ne contient aucun matériel nocif. Les panneaux en bois utilisés pour la production sont certifiés FSC - Forest Stewardship Council (bois des forêts gérés correctement et de manière responsable).



PRODUZIONE Lo stabilimento di Casalecchio di Reno (BO), per la lavorazione del metallo e la produzione di schermi e imbottiti possiede la certificazione ambientale ISO 14001 e ISO 9001. Lo stabilimento di Pezzan d'Istrana (TV), per le lavorazioni del legno, possiede le certificazioni ISO 14001 e ISO 9001. Le vernici epossidiche non contengono solventi o metalli pesanti e non sono soggette al rilascio di VOC.

PRODUCTION The Casalecchio di Reno plant, near Bologna, meets the environmental requirements for the metal processing and the screen and upholstery production according to the ISO 14001 and ISO 9001 certifications. The Pezzan d'Istrana plant meets the requirements for woodworking according to the ISO 14001 and ISO 9001 certifications. Epoxy paints do not contain solvents or heavy metals and do not release VOCs.

PRODUCTION L'usine de Casalecchio di Reno (BO), pour travailler avec les métaux et la production d'écrans rembourrés, a la certification environnementale ISO 14001 et ISO 9001. L'établissement de Pezzan d'Istrana (TV), pour le travail du bois, est certifié ISO 14001 et ISO 9001. Les peintures époxydique ne contiennent pas de solvants ou de métaux et ne sont pas soumis à la libération de COV.

E1

IL PANNELLO DI LEGNO TRUCIOLARE UTILIZZATO È CONFORME ALLO STANDARD E1 (EN 13986). LE COMPONENTI IN LEGNO DI WORKSTATION PORTANO IL MARCHIO FSC (FOREST STEWARDSHIP COUNCIL).

THE CHIPBOARD WOOD PANEL EMPLOYED IS IN COMPLIANCE WITH THE E1 STANDARD (EN 13986). WORKSTATION WOODEN COMPONENTS BEAR THE FSC BRAND (FOREST STEWARDSHIP COUNCIL).

LE PANNEAU DE PARTICULES UTILISÉ EST CONFORME À LA NORME E1 (EN 13986). LES COMPOSANTS EN BOIS DE WORKSTATION PORTENT LA MARQUE FSC - FOREST STEWARDSHIP COUNCIL (CONSEIL D'INTENDANCE DES FORÊTS).



MASCAGNI SPA È CERTIFICATA UNI EN ISO-9001 UNI EN ISO-14001

MASCAGNI SPA IS CERTIFIED ACCORDING TO UNI EN ISO-9001 UNI EN ISO-14001

MASCAGNI SPA EST CERTIFIÉE UNI EN ISO-9001 UNI EN ISO-14001



MASCAGNI SPA È MEMBRO DEL GREEN BUILDING COUNCIL ITALIA

MASCAGNI SPA IS MEMBER OF GREEN BUILDING COUNCIL ITALY

MASCAGNI SPA EST MEMBRE DU GREEN BUILDING COUNCIL ITALIE



© 2019 Mascagni S.p.A.
Tutti i diritti riservati
All rights reserved

Progetto grafico
Mascagni S.p.A.

Rendering
Studio Podrini S.r.l.

Copywriting
Alessio De Luca e Mascagni S.p.A.

Stampa
Zanini Industrie Grafiche S.r.l.

Stampato in 1500 copie
nel giugno 2019

99CCAT

Mascagni S.p.A. si riserva il diritto di apportare qualsiasi modifica tecnica ed estetica che ritenga necessaria.

The right is reserved by Mascagni SpA to make such technical, dimensional, and visual changes as are deemed appropriate.





Mascagni S.p.A.
40033 Casalecchio di Reno
(Bologna) Italy
Via Porrettana, 383
Tel. +39 0516111694
Fax: +39 0516111621
www.mascagniufficio.it
mascagni@mascagni.it



Mascagni Spazio Ufficio

E1 Il pannello di legno truciolare utilizzato
è conforme allo standard E1 (EN 13986).



UNI EN ISO - 9001
La Mascagni S.p.A. possiede la
certificazione di conformità ISO 9001

UNI EN ISO - 14001
La Mascagni S.p.A. ha conseguito la
certificazione ISO 14001



Mascagni S.p.A.